

**PILOT'S OPERATING HANDBOOK  
AND FAA APPROVED  
AIRPLANE FLIGHT MANUAL  
for the  
CIRRUS SR22T**

**Aircraft Serials SR22T-0442 & Subsequent with  
Teledyne Continental Motors Turbocharged Engine  
3600 Pound Takeoff Weight**



FAA Approved in Normal Category based on FAR 23. This document must be carried in the airplane at all times and be kept within the reach of the pilot during all flight operations.

THIS HANDBOOK INCLUDES THE MATERIAL REQUIRED TO BE FURNISHED TO THE PILOT BY FAR PART 23 AND ADDITIONAL INFORMATION PROVIDED BY CIRRUS DESIGN AND CONSTITUTES THE FAA APPROVED AIRPLANE FLIGHT MANUAL.

Model - Serial Num.: \_\_\_\_\_ Registration Num.: \_\_\_\_\_

FAA Approved *Joseph C. Miss* Date Feb 01, 2013  
for Charles Smalley, Manager  
Chicago Aircraft Certification Office, ACE-115C  
Federal Aviation Administration

P/N 13772-005  
Original Issue: February 01, 2013

CoverPage-i



Copyright © 2013 - All Rights Reserved  
Cirrus Design Corporation  
4515 Taylor Circle  
Duluth, MN 55811

## List of Effective Pages

Use this page to determine the current effective date for each page in the POH. Supplements are issued individually and are controlled by the Log of Supplements Page in Section 9.

Dates of original issue and revised pages are:

Original Issue..... 01 Feb 2013  
Revision..... 1 ..... 29 Dec 2015

Page	Status	Page	Status	Page	Status
Front Matter-1	Revision 1	2-18	Original Issue	3-25	Original Issue
Front Matter-2	Revision 1	2-19	Original Issue	3-26	Original Issue
Front Matter-3	Revision 1	2-20	Original Issue	3-27	Original Issue
Front Matter-4	Revision 1	2-21	Revision 1	3-28	Original Issue
Front Matter-5	Revision 1	2-22	Revision 1	3-29	Original Issue
Front Matter-6	Original Issue	2-23	Revision 1	3-30	Original Issue
1-1	Original Issue	2-24	Revision 1	3-31	Original Issue
1-2	Original Issue	2-25	Revision 1	3-32	Original Issue
1-3	Revision 1	2-26	Revision 1	3-33	Original Issue
1-4	Original Issue	2-27	Revision 1	3-34	Original Issue
1-5	Original Issue	2-28	Revision 1	3-35	Original Issue
1-6	Original Issue	2-29	Revision 1	3-36	Original Issue
1-7	Original Issue	2-30	Revision 1	3-37	Original Issue
1-8	Revision 1	3-1	Original Issue	3-38	Original Issue
1-9	Original Issue	3-2	Original Issue	3-39	Original Issue
1-10	Original Issue	3-3	Original Issue	3-40	Original Issue
1-11	Original Issue	3-4	Original Issue	3-41	Original Issue
1-12	Original Issue	3-5	Original Issue	3-42	Original Issue
1-13	Original Issue	3-6	Original Issue	3-43	Revision 1
1-14	Original Issue	3-7	Original Issue	3-44	Revision 1
2-1	Revision 1	3-8	Original Issue	3-45	Revision 1
2-2	Revision 1	3-9	Original Issue	3-46	Original Issue
2-3	Original Issue	3-10	Original Issue	3A-1	Original Issue
2-4	Original Issue	3-11	Original Issue	3A-2	Original Issue
2-5	Original Issue	3-12	Original Issue	3A-3	Revision 1
2-6	Original Issue	3-13	Original Issue	3A-4	Revision 1
2-7	Original Issue	3-14	Revision 1	3A-5	Original Issue
2-8	Original Issue	3-15	Original Issue	3A-6	Original Issue
2-9	Original Issue	3-16	Original Issue	3A-7	Original Issue
2-10	Original Issue	3-17	Original Issue	3A-8	Revision 1
2-11	Revision 1	3-18	Original Issue	3A-9	Original Issue
2-12	Original Issue	3-19	Original Issue	3A-10	Original Issue
2-13	Original Issue	3-20	Revision 1	3A-11	Original Issue
2-14	Original Issue	3-21	Original Issue	3A-12	Original Issue
2-15	Original Issue	3-22	Original Issue	3A-13	Original Issue
2-16	Original Issue	3-23	Original Issue	3A-14	Original Issue
2-17	Original Issue	3-24	Original Issue	3A-15	Original Issue

FAA Approved     Addison P. Tower     Dec 29, 2015  
Date \_\_\_\_\_  
for Timothy Smyth, Manager  
Chicago Aircraft Certification Office, ACE-115C  
Federal Aviation Administration

## List of Effective Pages (Cont.)

Page	Status	Page	Status	Page	Status
3A-16	Revision 1	5-15	Original Issue	7-22	Revision 1
3A-17	Original Issue	5-16	Original Issue	7-23	Revision 1
3A-18	Original Issue	5-17	Revision 1	7-24	Revision 1
3A-19	Original Issue	5-18	Revision 1	7-25	Revision 1
3A-20	Original Issue	5-19	Revision 1	7-26	Revision 1
3A-21	Original Issue	5-20	Revision 1	7-27	Revision 1
3A-22	Original Issue	5-21	Original Issue	7-28	Revision 1
3A-23	Original Issue	5-22	Original Issue	7-29	Revision 1
3A-24	Original Issue	5-23	Revision 1	7-30	Revision 1
4-1	Revision 1	5-24	Revision 1	7-31	Revision 1
4-2	Original Issue	5-25	Revision 1	7-32	Revision 1
4-3	Revision 1	5-26	Revision 1	7-33	Revision 1
4-4	Original Issue	5-27	Revision 1	7-34	Revision 1
4-5	Original Issue	5-28	Revision 1	7-35	Revision 1
4-6	Original Issue	5-29	Revision 1	7-36	Revision 1
4-7	Revision 1	5-30	Revision 1	7-37	Revision 1
4-8	Revision 1	5-31	Revision 1	7-38	Revision 1
4-9	Original Issue	5-32	Revision 1	7-39	Revision 1
4-10	Original Issue	5-33	Revision 1	7-40	Revision 1
4-11	Original Issue	5-34	Revision 1	7-41	Revision 1
4-12	Original Issue	5-35	Revision 1	7-42	Revision 1
4-13	Original Issue	5-36	Revision 1	7-43	Revision 1
4-14	Original Issue	5-37	Revision 1	7-44	Revision 1
4-15	Original Issue	5-38	Revision 1	7-45	Revision 1
4-16	Revision 1	6-1	Revision 1	7-46	Revision 1
4-17	Original Issue	6-2	Original Issue	7-47	Revision 1
4-18	Original Issue	6-3	Revision 1	7-48	Revision 1
4-19	Revision 1	6-4	Revision 1	7-49	Revision 1
4-20	Original Issue	6-5	Revision 1	7-50	Revision 1
4-21	Revision 1	6-6	Revision 1	7-51	Revision 1
4-22	Revision 1	6-7	Revision 1	7-52	Revision 1
4-23	Revision 1	6-8	Revision 1	7-53	Revision 1
4-24	Revision 1	6-9	Revision 1	7-54	Revision 1
4-25	Revision 1	6-10	Revision 1	7-55	Revision 1
4-26	Revision 1	7-1	Revision 1	7-56	Revision 1
4-27	Revision 1	7-2	Revision 1	7-57	Revision 1
4-28	Revision 1	7-3	Revision 1	7-58	Revision 1
4-29	Revision 1	7-4	Original Issue	7-59	Revision 1
4-30	Revision 1	7-5	Original Issue	7-60	Revision 1
4-31	Revision 1	7-6	Original Issue	7-61	Revision 1
4-32	Revision 1	7-7	Original Issue	7-62	Revision 1
5-1	Revision 1	7-8	Original Issue	7-63	Revision 1
5-2	Original Issue	7-9	Original Issue	7-64	Revision 1
5-3	Revision 1	7-10	Original Issue	7-65	Revision 1
5-4	Original Issue	7-11	Original Issue	7-66	Revision 1
5-5	Original Issue	7-12	Original Issue	7-67	Revision 1
5-6	Original Issue	7-13	Original Issue	7-68	Revision 1
5-7	Original Issue	7-14	Original Issue	7-69	Revision 1
5-8	Original Issue	7-15	Revision 1	7-70	Revision 1
5-9	Original Issue	7-16	Revision 1	7-71	Revision 1
5-10	Original Issue	7-17	Revision 1	7-72	Revision 1
5-11	Original Issue	7-18	Revision 1	7-73	Revision 1
5-12	Original Issue	7-19	Revision 1	7-74	Revision 1
5-13	Original Issue	7-20	Revision 1	7-75	Revision 1
5-14	Revision 1	7-21	Revision 1	7-76	Revision 1

## List of Effective Pages (Cont.)

Page	Status	Page	Status	Page	Status
7-77	Revision 1	8-24	Revision 1		
7-78	Revision 1	8-25	Original Issue		
7-79	Revision 1	8-26	Original Issue		
7-80	Revision 1	8-27	Revision 1		
7-81	Revision 1	8-28	Revision 1		
7-82	Revision 1	8-29	Revision 1		
7-83	Revision 1	8-30	Revision 1		
7-84	Revision 1	8-31	Revision 1		
7-85	Revision 1	8-32	Revision 1		
7-86	Revision 1	8-33	Revision 1		
7-87	Revision 1	8-34	Revision 1		
7-88	Revision 1	8-35	Revision 1		
7-89	Revision 1	8-36	Revision 1		
7-90	Revision 1	8-37	Revision 1		
7-91	Revision 1	8-38	Revision 1		
7-92	Revision 1	9-1	Revision 1		
7-93	Revision 1	9-2	Original Issue		
7-94	Revision 1	10-1	Original Issue		
7-95	Revision 1	10-2	Original Issue		
7-96	Revision 1	10-3	Original Issue		
7-97	Revision 1	10-4	Original Issue		
7-98	Revision 1	10-5	Original Issue		
7-99	Revision 1	10-6	Original Issue		
7-100	Revision 1	10-7	Original Issue		
7-101	Revision 1	10-8	Original Issue		
7-102	Revision 1	10-9	Revision 1		
7-103	Revision 1	10-10	Original Issue		
7-104	Revision 1	10-11	Original Issue		
7-105	Revision 1	10-12	Revision 1		
7-106	Revision 1	10-13	Revision 1		
7-107	Revision 1	10-14	Revision 1		
7-108	Revision 1				
8-1	Revision 1				
8-2	Original Issue				
8-3	Revision 1				
8-4	Revision 1				
8-5	Original Issue				
8-6	Original Issue				
8-7	Original Issue				
8-8	Original Issue				
8-9	Original Issue				
8-10	Original Issue				
8-11	Revision 1				
8-12	Original Issue				
8-13	Original Issue				
8-14	Original Issue				
8-15	Original Issue				
8-16	Revision 1				
8-17	Revision 1				
8-18	Revision 1				
8-19	Revision 1				
8-20	Original Issue				
8-21	Original Issue				
8-22	Original Issue				
8-23	Revision 1				

## List of Effective Pages (Cont.)

Page	Status	Page	Status	Page	Status
------	--------	------	--------	------	--------

Intentionally Left Blank

# SR22T Airplane Flight Manual (AFM)

## Temporary Change

Information in this Temporary Change adds to, supersedes, or deletes information in the basic Pilot's Operating Handbook.

- Affected Publications:
- SR22T Basic Airplane Flight Manuals:
- PN 13772-005 Rev 1 / 13772-003 Reissue A  
**(FAA Approved)**
  - PN 13772-005AR Original / 13772-003AR Reissue A  
**(FAA Approved on behalf of ANAC-DA of Argentina)**
  - PN 13772-005E Rev 1 / 13772-003E Rev 1  
**(FAA Approved on behalf of EASA)**
  - PN 21400-005 Rev 1 / 21400-003 Rev 1  
**(FAA Approved on behalf of ANAC of Brazil)**

Filing Instructions: Insert the following changes adjacent to the first page of each affected POH Section, and insert this TPOH cover page adjacent to the last page of the List of Effective Pages. Retain until further notice.

Purpose: This POH Temporary Change updates information associated with the Brake System. TPOH was revised 01 Nov 2019 to revise Affected Publications and update nose and main tire PSI.

---

---

### Affected Sections:

- Section 7 - Systems Description
- Section 8 - Handling and Servicing
- Section 10 - Safety Information

FAA Approved William P. Tower <sup>Nov 01, 2019</sup>  
Date  
Manager, Southwest Flight Test Section, AIR-713  
Federal Aviation Administration  
Ft. Worth, TX

Intentionally Left Blank



# SR22T Airplane Flight Manual (AFM)

## Temporary Change

Information in this Temporary Change adds to, supersedes, or deletes information in the basic Pilot's Operating Handbook.

Affected Publications: SR22T Basic Airplane Flight Manuals:  
• PN 13772-005 Rev 1 (FAA Approved)

Filing Instructions: Insert the following changes adjacent to the first page of each affected POH Section, and insert this TPOH cover page adjacent to the last page of the List of Effective Pages. Retain until further notice.

Purpose: This POH Temporary Change adds limitations and system descriptions associated with the GDL 88 UAT/ADS-B Transceiver.

---

---

### Affected Sections:

- Section 2 - Limitations
- Section 7 - Systems Description

FAA Approved

*Addison P. Tower*

Dec 30, 2015  
Date

for Timothy Smyth, Manager  
Chicago Aircraft Certification Office, ACE-115C  
Federal Aviation Administration

Intentionally Left Blank

# SR22T Airplane Flight Manual (AFM)

## Temporary Change

Information in this Temporary Change adds to, supersedes, or deletes information in the basic Pilot's Operating Handbook.

Affected Publications: SR22T Basic Airplane Flight Manuals:

- PN 13772-005 Rev 1 (FAA Approved)
- PN 13772-005E Rev 1 (FAA Approved on Behalf of the European Aviation Safety Agency (EASA))
- PN 13772-005AR Original Issue (FAA Approved on Behalf of ANAC-DA of Argentina)
- PN 21400-005 Rev 1 (FAA Approved on Behalf of ANAC of Brazil)

Filing Instructions: Insert the following changes adjacent to the first page of each affected POH Section, and insert this TPOH cover page adjacent to the last page of the List of Effective Pages. Retain until further notice.

Purpose: This POH Temporary Change adds system descriptions associated with the Flight Stream 210 Bluetooth™ Transceiver and GMA 350c Audio Panel. TPOH was revised May 18, 2016 to add Affected Publications.

---

---

### Affected Sections:

- Section 7 - Systems Description

FAA Approved     Addison P. Tower     May 18, 2016  
Date \_\_\_\_\_  
for Timothy Smyth, Manager  
Chicago Aircraft Certification Office, ACE-115C  
Federal Aviation Administration

Intentionally Left Blank

# SR22T Airplane Flight Manual (AFM)

## Temporary Change

Information in this Temporary Change adds to, supersedes, or deletes information in the basic Pilot's Operating Handbook.

Affected Publications:	SR22T Basic Airplane Flight Manuals: <ul style="list-style-type: none"><li>• P/N 13772-003 Reissue A / 13772-005 Rev 1 <b>(FAA Approved)</b></li><li>• P/N 13772-003AR Reissue A / 13772-005AR Rev 1 <b>(FAA Approved on behalf of ANAC-DA of Argentina)</b></li><li>• P/N 13772-003E Rev 1 / 13772-005E Rev 1 <b>(FAA Approved on behalf of EASA)</b></li><li>• P/N 21400-003 Rev 1 / 21400-005 Rev 1 <b>(FAA Approved on behalf of ANAC of Brazil)</b></li></ul>
Filing Instructions:	Insert the following changes adjacent to the first page of the affected POH Section, and insert this TPOH cover page adjacent to the last page of the List of Effective Pages. Retain until further notice.
Purpose:	This POH Temporary Change adds FUEL FLOW Warning CAS Message to Fuel System Emergencies.

---

---

### Affected Sections:

- Section 3 - Emergency Procedures

**FAA Approved**

Addison  
Preston  
Tower

Digitally signed by  
Addison Preston  
Tower  
Date: 2020.10.27  
09:22:01 -05'00'

**Date** 27 OCT 2020

Manager, Southwest Flight Test Section, AIR-713  
Federal Aviation Administration  
Ft. Worth, TX

Intentionally Left Blank

## Foreword

This Pilot's Operating Handbook (POH) has been prepared by Cirrus Design Corporation to familiarize operators with the aircraft. Read this POH carefully. It provides operational procedures that will assure the operator obtains the performance published in the manual, data designed to allow the most efficient use of the airplane, and basic information for maintaining the airplane in a "like new" condition.

• Note •

All limitations, procedures, maintenance & servicing requirements, and performance data contained in this POH are mandatory for compliance with FAA operating rules and for continued airworthiness of the airplane.

This POH includes the material required to be furnished to the pilot by the Federal Aviation Regulations (FARs) and additional information provided by Cirrus Design Corporation and constitutes the FAA Approved Airplane Flight Manual for the aircraft.

## The Pilot's Operating Handbook

This Pilot's Operating Handbook has been prepared using GAMA Specification #1 for Pilot's Operating Handbook, Revision 2, dated 18 October 1996 as the content model and format guide. However, some deviations from this specification were made for clarity. The POH is presented in loose-leaf form for ease in inserting revisions and is sized for convenient storage. Tabbed dividers throughout the POH allow quick reference to each section. Logical and convenient Tables of Contents are located at the beginning of each section to aid in locating specific data within that section. The POH is divided into ten sections as follows:

Section 1.....	General
Section 2.....	Limitations
Section 3.....	Emergency Procedures
Section 3A.....	Abnormal Procedures
Section 4.....	Normal Procedures
Section 5.....	Performance Data
Section 6.....	Weight & Balance/Equipment List
Section 7.....	Systems Description
Section 8.....	Handling, Servicing & Maintenance
Section 9.....	Supplements
Section 10.....	Safety Information

The data presented in this POH is the result of extensive flight tests and is approved by the Federal Aviation Administration. However, as new procedures or performance data are developed, the POH will be revised.

• Note •

It is the responsibility of the owner to ensure that the Pilot's Operating Handbook is current at all times. Therefore, it is very important that all revisions be properly incorporated into this POH as soon as they are available.



## Revising the Pilot's Operating Handbook

Two types of revisions may be issued for this POH: Temporary and Numbered.

Temporary revisions are printed on yellow paper, normally cover only one topic or procedure, and are issued to provide safety related information or other time sensitive information where the rigor of providing a numbered revision is not possible in the time allowed. All the information needed to properly file a temporary revision is included on the revision itself. Typically, a temporary revision is superseded and replaced by the next numbered revision.

Numbered revisions are printed on white paper, normally cover several subjects, and are issued as general updates to the POH. Each numbered revision includes an "Instruction Sheet," a "List of Effective Pages", and a "Revision Highlights" page. The "Instruction Sheet" is intended to assist the manual holder in removing superseded pages and inserting new or superseding pages. The "List of Effective Pages" shows the issue or revision status of all pages in the POH. The "Revision Highlights" page gives a brief description of changes made to each page in the current revision.

### Identifying Revised Material

Each page in the POH has revision identification at the lower inside corner opposite the page number. Original issue pages will be identified by the words "Original Issue" at this location. In the event that the majority of pages in the POH are revised, Cirrus may determine that it is more effective to reissue the POH. Reissued pages will be identified by the word "Reissue" followed by a letter indicating the reissue level; for example, "Reissue A" Revised pages will be identified by the word "Revision" followed by the revision number at this location; for example, "Revision 2" (Original Issue, Revision 2) or "Revision B1" (Reissue B, Revision 1).

Revised material on a page can be identified by a change bar located at the outside page margin. Revision bars are not used at reissues of the POH.

## Revisions to the Pilot's Operating Handbook

POH revisions, temporary revisions, and supplements can be downloaded from Cirrus Design at [www.cirrusaircraft.com](http://www.cirrusaircraft.com), or from the Authorized Service Center website.

Paper copies of POH revisions and supplements can be purchased from Cirrus Connection at [www.cirrusconnection.com](http://www.cirrusconnection.com).

### • Note •

If at any time it is found that the POH is not current, temporary revisions are missing, or applicable supplements are not included, contact Cirrus Design.

## Supplements

The Supplements section (Section 9) of this POH contains FAA Approved Supplements necessary to safely and efficiently operate the airplane when equipped with optional equipment not provided with the standard airplane or not included in the POH. Supplements are essentially “mini-handbooks” and may contain data corresponding to most sections of the POH. Data in a supplement either adds to, supersedes, or replaces similar data in the basic POH.

Section 9 includes a “Log of Supplements” page preceding all Cirrus Design Supplements produced for this airplane. The “Log of Supplements” page can be utilized as a “Table of Contents” for Section 9. If the airplane is modified at a non Cirrus Design facility through an STC or other approval method, it is the owner’s responsibility to ensure that the proper supplement, if applicable, is installed in the POH and that the supplement is properly recorded on the “Log of Supplements” page.

FAA Approved POH Supplements must be in the airplane for flight operations when the subject optional equipment is installed or the special operations are to be performed.

## Retention of Data

In the event a new title page is issued, the weight and balance data changes, the equipment list changes, or the “Log of Supplements” is replaced, the owner must ensure that all information applicable to the airplane is transferred to the new pages and the aircraft records are current. It is not a requirement that owners retain information, such as supplements, that is not applicable to their airplane.

In the event a new POH is purchased, the owner must ensure that all information applicable to the airplane is transferred to the new POH and the aircraft records are current.

## **Warnings, Cautions, and Notes**

Warnings, Cautions, and Notes are used throughout this POH to focus attention on special conditions or procedures as follows:

### **• WARNING •**

Warnings are used to call attention to operating procedures which, if not strictly observed, may result in personal injury or loss of life.

### **• Caution •**

Cautions are used to call attention to operating procedures which, if not strictly observed, may result in damage to equipment.

### **• Note •**

Notes are used to highlight specific operating conditions or steps of a procedure.

Intentionally Left Blank

# ***Section 1: General***

## **Table of Contents**

Introduction .....	3
The Airplane.....	7
Engine.....	7
Propeller .....	7
Fuel .....	8
Oil .....	8
Maximum Certificated Weights .....	8
Cabin and Entry Dimensions .....	8
Baggage Spaces and Entry Dimensions .....	8
Specific Loadings.....	8
Symbols, Abbreviations and Terminology.....	9
General Airspeed Terminology and Symbols .....	9
Meteorological Terminology.....	10
Engine Power Terminology.....	11
Performance and Flight Planning Terminology.....	12
Weight and Balance Terminology.....	12

Intentionally Left Blank

## Introduction

This section contains information of general interest to pilots and owners. You will find the information useful in acquainting yourself with the airplane, as well as in loading, fueling, sheltering, and handling the airplane during ground operations. Additionally, this section contains definitions or explanations of symbols, abbreviations, and terminology used throughout this handbook.

• Note •

For specific information regarding the organization of this Handbook, revisions, supplements, and procedures to be used to obtain publications, see the "Foreword" section.

All liquid volumes referenced in this publication are expressed in United States Customary Units, e.g., U.S. Gallons.

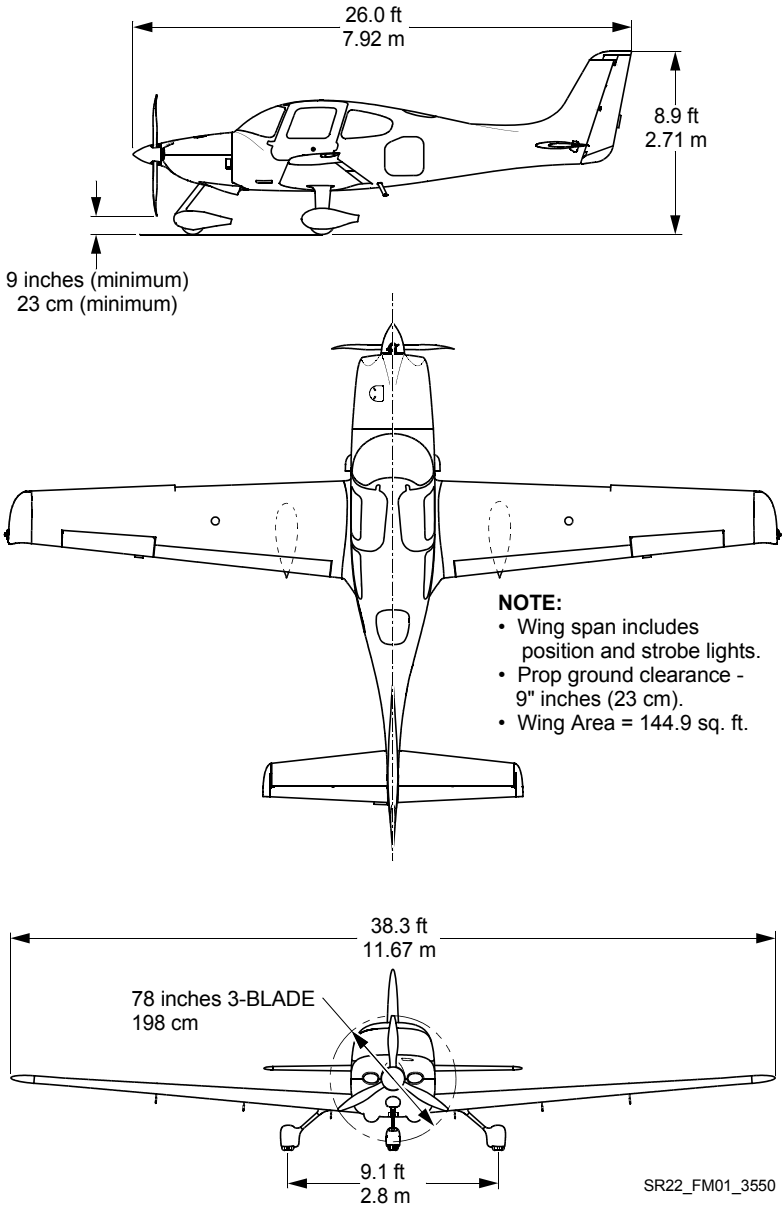

**Figure 1-1**  
**Airplane Three View**



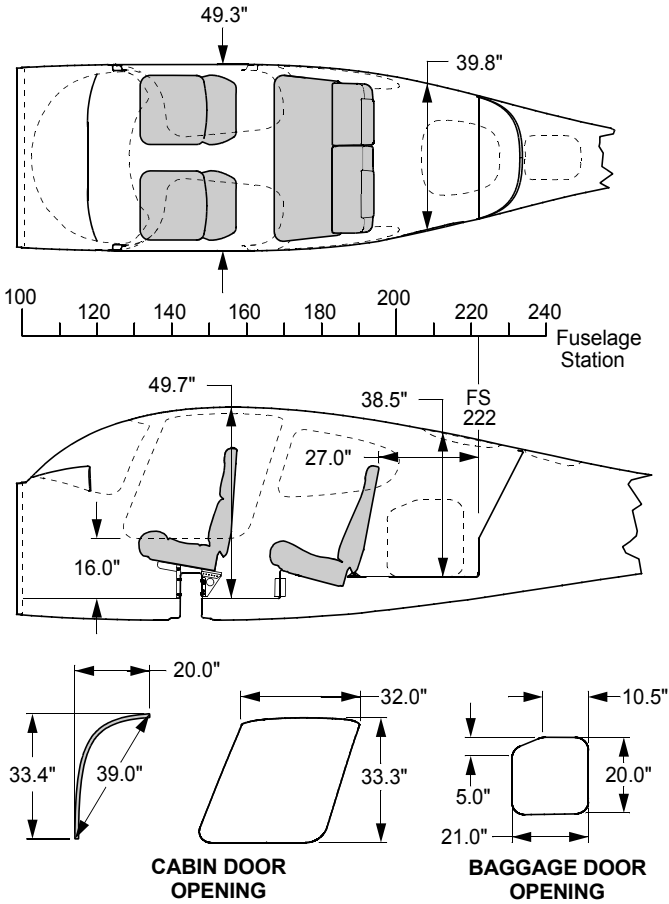

SR22\_FM01\_1019A

Location	Length	Width	Height	Volume
Cabin	122"	49.3"	49.7	137 cu ft
Baggage Compartment	36"	39.8"	38.5"	32 cu ft

**Figure 1-2**  
**Airplane Interior Dimensions**

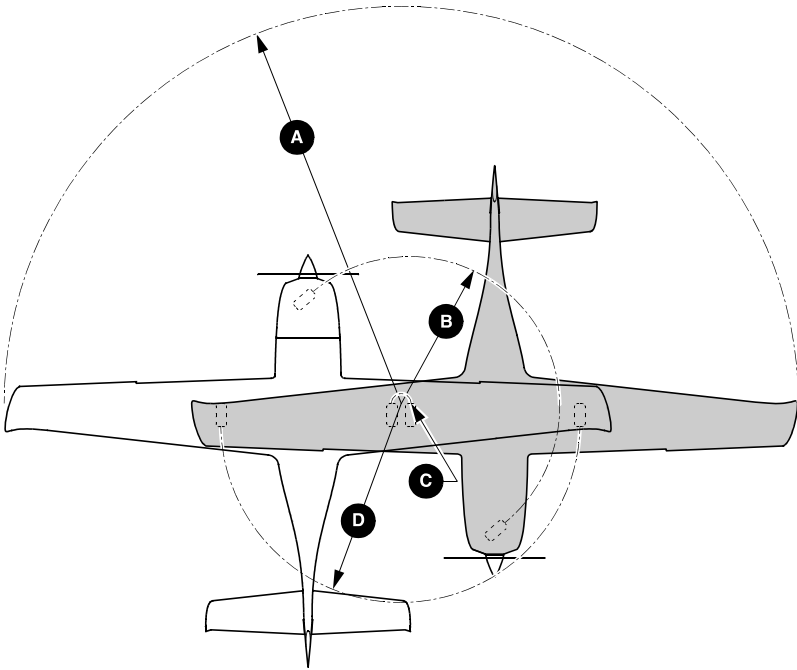

**GROUND TURNING CLEARANCE**

- A** RADIUS FOR WING TIP ..... 24.3 ft. (7.41 m)
- B** RADIUS FOR NOSE GEAR ..... 7.0 ft. (2.16 m)
- C** RADIUS FOR INSIDE GEAR ..... 0.5 ft. (0.15 m)
- D** RADIUS FOR OUTSIDE GEAR ..... 9.1 ft. (2.77 m)

TURNING RADII ARE CALCULATED USING ONE BRAKE AND PARTIAL POWER. ACTUAL TURNING RADIUS MAY VARY AS MUCH AS THREE FEET.

SR22\_FM01\_2412

**Figure 1-3**  
**Turning Radius**

# The Airplane

## Engine

Number of Engines..... 1  
Engine Manufacturer ..... Teledyne **Continental**  
Engine Model ..... TSIO-550-K  
Engine Type ..... Turbocharged, direct drive, fuel injected, air cooled,  
horizontally opposed 6 cylinder engine with 550 cubic inch  
displacement.  
**Horsepower Rating..... 315 bhp @ 2500 rpm**

## Propeller

***Hartzell Compact Series Lightweight Hub with Composite Blades***  
Propeller Type ..... Constant Speed, Three Blade  
Model Number ..... PHC-J3Y1F-1N/N7605(B)  
Diameter ..... 78.0"  
Model Number ..... PHC-J3Y1F-1N/N7605C(B)  
Diameter ..... 78.0"

## Fuel

Total Capacity ..... 94.5 U.S. Gallons (358.0 L)

Total Usable ..... 92.0 U.S. Gallons (348.0 L)

Approved Fuel Grades:

100 LL Grade Aviation Fuel (Blue)

100 (Formerly 100/130) Grade Aviation Fuel (Green)

## Oil

Oil Capacity (Sump) ..... 8 U.S. Quarts (7.6 L)

Oil Grades:

All Temperatures ..... 15W-50, 20W-50 or 20W-60

Above 40°F (4°C) ..... SAE 50, 20W50, or 20W60

Below 40°F (4°C) ..... SAE 30, 10W30, 15W50, or 20W50

## Maximum Certificated Weights

Maximum Gross for Takeoff ..... 3600 lb (1633 Kg)

Maximum Zero Fuel Weight ..... 3400 lb (1542 Kg)

Maximum Baggage Compartment Loading ..... 130 lb (59 Kg)

## Cabin and Entry Dimensions

Refer to the preceding figures for dimensions of the cabin interior and entry door openings.

## Baggage Spaces and Entry Dimensions

Refer to the preceding figures for dimensions of the baggage area and baggage door opening.

## Specific Loadings

Wing Loading ..... 24.8 lb per square foot

Power Loading ..... 11.4 lb per hp

# Symbols, Abbreviations and Terminology

## General Airspeed Terminology and Symbols

KCAS	Knots Calibrated Airspeed is the indicated airspeed corrected for position and instrument error. Calibrated airspeed is equal to true airspeed in standard atmosphere at sea level.
KIAS	Knots Indicated Airspeed is the speed shown on the airspeed indicator. The IAS values published in this handbook assume no instrument error.
KTAS	Knots True Airspeed is the airspeed expressed in knots relative to undisturbed air which is KCAS corrected for altitude and temperature.
$V_G$	Best Glide Speed is the speed at which the greatest flight distance is attained per unit of altitude lost with power off.
$V_O$	Operating Maneuvering Speed is the maximum speed at which application of full control movement will not overstress the airplane.
$V_{FE}$	Maximum Flap Extended Speed is the highest speed permissible with wing flaps in a prescribed extended position.
$V_{NO}$	Maximum Structural Cruising Speed is the speed that should not be exceeded except in smooth air, and then only with caution.
$V_{NE}$	Never Exceed Speed is the speed that may not be exceeded at any time.
$V_{PD}$	Maximum Demonstrated Parachute Deployment Speed is the maximum speed at which parachute deployment has been demonstrated.
$V_{REF}$	Landing reference speed or threshold crossing speed.
$V_S$	Stalling Speed is minimum steady flight speed at which the aircraft is controllable.

- $V_S$  50% Stalling Speed is minimum steady flight speed at which the aircraft is controllable with 50% flaps.
- $V_{SO}$  Stalling Speed is the minimum steady flight speed at which the aircraft is controllable in the landing configuration (100% flaps) at the most unfavorable weight and balance.
- $V_X$  Best Angle of Climb Speed is the speed at which the airplane will obtain the highest altitude in a given horizontal distance. The best angle-of-climb speed normally increases slightly with altitude.
- $V_Y$  Best Rate of Climb Speed is the speed at which the airplane will obtain the maximum increase in altitude per unit of time. The best rate-of-climb speed decreases slightly with altitude.

## Meteorological Terminology

- IMC Instrument Meteorological Conditions are meteorological conditions expressed in terms of visibility, distance from cloud, and ceiling less than the minima for visual flight defined in FAR 91.155.
- ISA International Standard Atmosphere (standard day) is an atmosphere where (1) the air is a dry perfect gas, (2) the temperature at sea level is 15°C, (3) the pressure at sea level is 29.92 in.Hg (1013.2 millibars), and (4) the temperature gradient from sea level to the altitude at which the temperature is -56.5°C is -0.00198°C per foot and zero above that altitude.
- MSL Mean Sea Level is the average height of the surface of the sea for all stages of tide. In this Handbook, altitude given as MSL is the altitude above the mean sea level. It is the altitude read from the altimeter when the altimeter's barometric adjustment has been set to the altimeter setting obtained from ground meteorological sources.

OAT	Outside Air Temperature is the free air static temperature obtained from inflight temperature indications or from ground meteorological sources. It is expressed in either degrees Celsius or degrees Fahrenheit.
Pressure Altitude	Pressure Altitude (PA) is the altitude read from the altimeter when the altimeter's barometric adjustment has been set to 29.92 in.Hg (1013 mb) corrected for position and instrument error. In this Handbook, altimeter instrument errors are assumed to be zero.
Standard Temperature	Standard Temperature is the temperature that would be found at a given pressure altitude in the standard atmosphere. It is 15°C (59°F) at sea level pressure altitude and decreases approximately 2°C (3.6°F) for each 1000 feet of altitude increase. See ISA definition.

## Engine Power Terminology

BHP	Brake Horsepower is the power developed by the engine.
MCP	Maximum Continuous Power is the maximum power that can be used continuously.
MAP	Manifold Pressure is the pressure measured in the engine's induction system expressed as inches of mercury (in.Hg).
RPM	Revolutions Per Minute is engine rotational speed.
Static RPM	Static RPM is RPM attained during a full-throttle engine runup when the airplane is on the ground and stationary.
TIT	Turbine Inlet Temperature is the temperature measured in front of the first stage turbine nozzle valves.

## Performance and Flight Planning Terminology

g	One “g” is a quantity of acceleration equal to that of earth’s gravity.
Demonstrated Crosswind Velocity	Demonstrated Crosswind Velocity is the velocity of the crosswind component for which adequate control of the airplane during taxi, takeoff, and landing was actually demonstrated during certification testing. Demonstrated crosswind is not considered to be limiting.
Service Ceiling	Service Ceiling is the maximum altitude at which the aircraft at maximum weight has the capability of climbing at a rate of 100 feet per minute.
GPH	Gallons Per Hour is the amount of fuel (in gallons) consumed by the aircraft per hour.
NMPG	Nautical Miles Per Gallon is the distance (in nautical miles) which can be expected per gallon of fuel consumed at a specific engine power setting and/or flight configuration.
Unusable Fuel	Unusable Fuel is the quantity of fuel that cannot be safely used in flight.
Usable Fuel	Usable Fuel is the fuel available for flight planning.

## Weight and Balance Terminology

Reference Datum	Reference Datum is an imaginary vertical plane from which all horizontal distances are measured for balance purposes.
Station	Station is a location along the airplane fuselage measured in inches from the reference datum and expressed as a number. For example: A point 123 inches aft of the reference datum is Fuselage Station 123.0 (FS 123).
CG	Center of Gravity is the point at which an airplane would balance if suspended. Its distance from the reference datum is found by dividing the total moment by the total weight of the airplane.



Arm	Arm is the horizontal distance from the reference datum to the center of gravity (CG) of an item. The airplane's arm is obtained by adding the airplane's individual moments and dividing the sum by the total weight.
Moment	Moment is the product of the weight of an item multiplied by its arm.
Standard Empty Weight	Standard Empty Weight is the weight of a standard airplane including unusable fuel, full operating fluids, and full oil
Basic Empty Weight	Basic Empty Weight is the actual weight of the airplane including all operating equipment that has a fixed location in the airplane. The basic empty weight includes the weight of unusable fuel and full oil.
Maximum Ramp Weight	Maximum Ramp Weight is the maximum weight approved for ground maneuver and includes the weight of the fuel used for startup, taxi, and run-up.
Maximum Gross Weight	Maximum Gross Weight is the maximum permissible weight of the airplane and its contents as listed in the aircraft specifications.
Maximum Zero Fuel Weight	Maximum Zero Fuel Weight is the maximum permissible weight of the airplane and its contents minus the total weight of the fuel onboard.
Useful Load	Useful Load is the basic empty weight subtracted from the maximum ramp weight. It is the maximum allowable combined weight of pilot, passengers, fuel and baggage.
MAC	Mean Aerodynamic Chord is the chord drawn through the centroid of the wing plan area.
LEMAC	Leading Edge of Mean Aerodynamic Chord is the forward edge of MAC given in inches aft of the reference datum (fuselage station).

**Tare**

Tare is the weight of all items used to hold or position the airplane on the scales for weighing. Tare includes blocks, shims, and chocks. Tare weight must be subtracted from the associated scale reading.

# Section 2: Limitations

## Table of Contents

Introduction .....	3
Certification Status .....	3
Airspeed Limitations .....	4
Airspeed Indicator Markings .....	5
Powerplant Limitations .....	6
Engine .....	6
Operating Limits .....	6
Approved Oils: .....	6
Fuel Grade .....	7
Weight Limits .....	7
Engine Instrument Markings & Annunciations .....	8
PowerPlant .....	8
Fuel .....	9
Electrical .....	9
Center of Gravity Limits .....	10
Maneuver Limits .....	11
Flight Load Factor Limits .....	11
Minimum Flight Crew .....	11
Kinds of Operation .....	12
Kinds of Operation Equipment List .....	12
Icing .....	16
Runway Surface .....	16
Taxi Power .....	17
Fuel Limits .....	17
Altitude Limits .....	17
Environmental Conditions .....	17
Maximum Occupancy .....	18
Systems and Equipment Limits .....	19
Cirrus Perspective Integrated Avionics System .....	19
L-3 Skywatch Traffic Advisory System (Optional) .....	22
L-3 Stormscope Weather Information System (Optional) .....	22
Max Viz Enhanced Vision System (Optional) .....	23
MD302 Standby Attitude Module (Optional) .....	23
Air Conditioning System (Optional) .....	23
Inflatable Restraint System .....	23
Flap Limitations .....	23

**Section 2**  
**Limitations**

**Cirrus Design**  
**SR22T**

Paint..... 24  
Cirrus Airframe Parachute System (CAPS) ..... 24  
Other Limitations ..... 24  
    Smoking ..... 24  
Placards ..... 25

## **Section 2 - Limitations**

### **Systems and Equipment Limits**

#### **ADS-B OUT Equipment, including GDL 88 UAT/ADS-B Transceiver and GTX 33ES Mode S with Extended Squitter (Optional)**

1. The installed ADS-B OUT system has been shown to meet the equipment requirements of 14 CFR 91.227.

#### **FIS-B Receiver Equipment, including GDL 88 UAT/ADS-B Transceiver (Optional)**

1. Flight Information Services - Broadcast (FIS-B) information is intended to enhance pilot awareness of weather and airspace conditions. It does not replace positive two way communication when making safety critical weather or routing decisions. Use FIS-B weather and National Airspace System (NAS) status information as follows:
  - a. To aid pilot awareness of hazardous meteorological conditions and awareness of the regulatory status of the airspace.
  - b. FIS-B information is meant to enhance flight planning only. It lacks sufficient resolution and updating necessary for tactical maneuvering.

Intentionally Left Blank

## Introduction

The limitations included in this Section of the Pilot's Operating Handbook (POH) are approved by the Federal Aviation Administration.

This section provides operating limitations, instrument markings and basic placards required by regulation and necessary for the safe operation of the aircraft and its standard systems and equipment. Refer to [Section 9: Log of Supplements](#) of this handbook for amended operating limitations for airplanes equipped with optional equipment. Compliance with the operating limitations in this section and in Section 9 is required by Federal Aviation Regulations.

• Note •

Limitations associated with optional equipment are not described in this section. For optional equipment limitations, refer to [Section 9: Log of Supplements](#).

## Certification Status

The aircraft is certificated under the requirements of Federal Aviation Regulations (FAR) Part 23 as documented by FAA Type Certificate TC A00009CH.

## Airspeed Limitations

The indicated airspeeds in the following table are based on Section 5, *Airspeed Calibration: Normal Static Source* Table. When using the alternate static source, allow for the airspeed calibration variations between the normal and alternate static sources.

Speed	KIAS	KCAS	Remarks
V <sub>NE</sub> up to 17,500 feet MSL	205	208	<b>Never Exceed Speed</b> is the speed that may not be exceeded at any time.
V <sub>NE</sub> at 25,000 feet MSL	175	178	V <sub>NE</sub> is reduced linearly from 17,500 feet to 25,000 feet.
V <sub>NO</sub> up to 17,500 feet MSL	176	179	<b>Maximum Structural Cruising Speed</b> is the speed that should not be exceeded except in smooth air and then only with caution.
V <sub>NO</sub> at 25,000 feet MSL	150	153	V <sub>NO</sub> is reduced linearly from 17,500 feet to 25,000 feet.
V <sub>O</sub> 3600 Lb	140	142	<b>Operating Maneuvering Speed</b> is the maximum speed at which full control travel may be used. Below this speed the airplane stalls before limit loads are reached. Above this speed, full control movements can damage the airplane.
V <sub>FE</sub>  50% Flaps 100% Flaps	150 110	152 111	<b>Maximum Flap Extended Speed</b> is the highest speed permissible with wing flaps extended.
V <sub>PD</sub>	140	142	<b>Maximum Demonstrated Parachute Deployment Speed</b> is the maximum speed at which parachute deployment has been demonstrated.



## Airspeed Indicator Markings

The airspeed indicator markings are based on Section 5, *Airspeed Calibration: Normal Static Source* Table. When using the alternate static source, allow for the airspeed calibration variations between the normal and alternate static sources.

Marking	Value (KIAS)	Remarks
White Arc	64 - 110	Full Flap Operating Range Lower limit is the most adverse stall speed in the landing configuration. Upper limit is the maximum speed permissible with flaps extended. Do not use flaps above 17,500 feet MSL.
Green Arc up to 17,500 feet MSL 25,000 feet MSL	74 - 176 74 - 150	Normal Operating Range Lower limit is the maximum weight stall at most forward C.G. with flaps retracted. Upper limit is the maximum structural cruising speed ( $V_{NO}$ ). $V_{NO}$ and upper limit of green arc is reduced linearly from 17,500 feet to 25,000 feet.
Yellow Arc up to 17,500 MSL 25,000 feet MSL	176 - 205 150 - 175	Caution Range Operations must be conducted with caution and only in smooth air. Upper and lower limits of yellow arc are reduced linearly from 17,500 feet to 25,000 feet.
Red Line up to 17,500 feet MSL 25,000 feet MSL	205 175	Never Exceed Speed ( $V_{NE}$ ) Maximum speed for all operations. $V_{NE}$ and red line is reduced linearly from 17,500 feet to 25,000 feet.

## Powerplant Limitations

### Engine

Number of Engines ..... 1  
Engine Manufacturer ..... Teledyne Continental  
Engine Model..... TSIO-550-K  
Engine Type..... Turbocharged, direct drive, fuel injected, air cooled,  
horizontally opposed 6 cylinder engine with 550 cubic inch  
displacement.  
Horsepower Rating ..... 315 bhp @ 2500 rpm  
Oil Temperature ..... 240 °F (116 °C) maximum  
Minimum Oil Temperature for Takeoff..... 75 °F (24 °C)  
Oil Pressure:  
    Minimum ..... 10 psi  
    Maximum ..... 100 psi

### Operating Limits

Do not reduce manifold pressure below 15 inches when above 18,000 ft MSL.

### Approved Oils:

*Engine Break-In:* For first 25 hours of operation or until oil consumption stabilizes use straight mineral oil conforming to MIL-C-6529. If engine oil must be added to the factory installed oil, add only MIL-C-6529 straight mineral oil.

*After Engine Break-In:* Use only oils conforming to Teledyne Continental Specification SAE J 1899 (Ashless Dispersant Lubrication Oil).

All Temperatures ..... 15W-50, 20W-50 or 20W-60  
Above 40 °F (4 °C).....SAE 50, 20W50, or 20W60  
Below 40 °F (4 °C) ..... SAE 30, 10W30, 15W50, or 20W50

## Fuel Grade:

Aviation Grade 100 LL (Blue) or 100 (green)

• Note •

Refer to *Fuel Limits* in this Section for operational limitations regarding fuel and fuel storage.

## Propeller

### *Hartzell Compact Series Lightweight Hub with Composite Blades*

Propeller Type ..... Constant Speed, Three Blade

Model Number ..... PHC-J3Y1F-1N/N7605(B)

Diameter ..... 78.0"

Model Number ..... PHC-J3Y1F-1N/N7605C(B)

Diameter ..... 78.0"

## Weight Limits

Maximum Takeoff Weight ..... 3600 lb (1633 Kg)

Maximum Weight in Baggage Compartment ..... 130 lb (59 Kg)

Maximum Zero Fuel Weight ..... 3400 lb (1542 Kg)

## Engine Instrument Markings & Annunciations

The following describes the engine instrument markings. Associated Warning and Caution Annunciations are shown in capitalized text.

### PowerPlant

Instrument (Range & Units)	Red Arc/Bar	Yellow Arc/Bar	Green Arc/Bar	Yellow Arc/Bar	Red Arc/Bar
	Lower Warning Range	Minimum Caution Range	Normal Range	Maximum Caution Range	Upper Warning Range
Cylinder Head Temperature (100°F – 500°F)	—	—	240 – 420	420 – 460 CHT	> 460 CHT
Engine Speed (0 – 3000 RPM)	—	—	500 – 2550	—	> 2550 RPM
Exhaust Gas Temperature (1000°F – 1800°F)	—	—	1000–1800	—	—
Manifold Pressure (10 – 40 in.Hg)	—	—	15.0 - 36.5	36.5 - 37.5	37.5 - 40.0
Oil Pressure (0 – 100 PSI)	0 – 10	10 – 30 OIL PRESS	30 – 60	60 – 100	> 100 OIL PRESS
Oil Temperature (75°F – 250°F)	—	—	100 – 240	—	> 240 OIL TEMP
Percent Power (0 – 100%)	—	—	0 – 100	—	—
Turbocharger Inlet Temperature (1000°F - 1800°F)	—	—	1000 – 1750	—	1750 -1800 TIT

## Fuel

Instrument (Range & Units)	Red Arc/Bar	Yellow Arc/ Bar	Green Arc/ Bar	Yellow Arc/ Bar	Red Arc/Bar
	Minimum	Minimum Caution Range	Normal Range	Maximum Caution Range	Maximum
Fuel Flow (0 – 45 U.S. Gal./Hr.)	—	—	*See Note	—	—
Fuel Totalizer (U.S. Gallon)	N < 9 FUEL QTY	9 – 18	> 18	—	—
Fuel Quantity Gage (0 – 46 U.S. Gallon)	0	10 – 14	14 – 46	—	—

\* Dynamically changes based on engine parameters.

## Electrical

Instrument (Range & Units)	Red Arc/Bar	Yellow Arc/Bar	Green Arc/ Bar	Yellow Arc/Bar	Red Arc/Bar
	Minimum	Minimum Caution Range	Normal Range	Maximum Caution Range	Maximum
Essential Bus Volts (0 – 36 Volts)	0 – 24.4 ESS BUS	—	24.5 – 32	—	> 32 ESS BUS
Main Bus 1 Voltage (0 – 36 Volts)	—	0 – 24.4 M BUS 1	24.5 – 32	—	> 32 M BUS 1
Main Bus 2 Voltage (0 – 36 Volts)	—	0 – 24.4 M BUS 2	24.5 – 32	—	> 32 M BUS 2
Alternator 1 Current (0 – 100 Amps)	—	—	2 – 100	0 – 1 ALT 1	—
Alternator 2 Current (0 – 100 Amps)	—	—	2 – 100	0 – 1 ALT 2	—
Battery 1 Current (-59 to 59 Amps)	—	—	-4 – 59	-59 to -5 BATT 1	—

# Center of Gravity Limits

Reference Datum ..... 100 inches forward of firewall  
 Forward ..... Refer to Figure 2-1  
 Aft ..... Refer to Figure 2-1

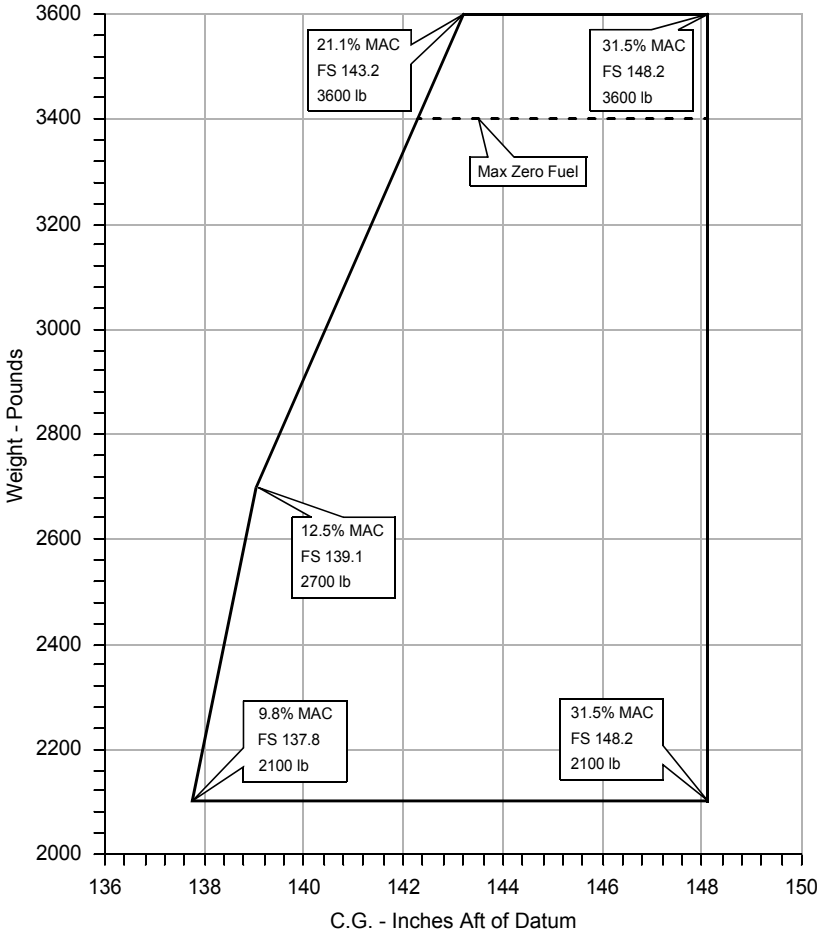

SR22\_FM02\_3216

**FORWARD LIMIT** - The forward limit is FS 137.8 (9.8% MAC) at 2100 lb, with straight line taper to FS 139.1 (12.5% MAC) at 2700 lb, to FS 143.2 (21.1% MAC) at 3600 lb.  
**AFT LIMIT** - The aft limit is FS 148.2 (31.5% MAC) at all weights from 2100 lb to 3600 lb.

**Figure 2-1**  
**CG Envelope**

## Maneuver Limits

Aerobatic maneuvers are prohibited.

Spins are prohibited.

This airplane is certified in the normal category and is not designed for aerobatic operations. Only those operations incidental to normal flight are approved. These operations include normal stalls, chandelles, lazy eights, and turns in which the angle of bank is limited to 60°.

• Note •

Because the aircraft has not been certified for spin recovery, the Cirrus Airframe Parachute System (CAPS) must be deployed if the airplane departs controlled flight. Refer to Section 3, *Inadvertent Spin Entry*.

## Flight Load Factor Limits

Flaps UP (0%), 3600 lb. ....	+3.8g, -1.9g
Flaps 50%, 3600 lb.....	+1.9g, 0g
Flaps 100%, 3600 lb.....	+1.9g, 0g

## Minimum Flight Crew

The minimum flight crew is one pilot.

## Kinds of Operation

The aircraft is equipped and approved for the following type operations:

- VFR day and night.
- IFR day and night.

## Kinds of Operation Equipment List

The following listing summarizes the equipment required under Federal Aviation Regulations (FAR) Part 23 for airworthiness under the listed kind of operation. Those minimum items of equipment necessary under the operating rules are defined in FAR Part 91 and FAR Part 135 as applicable.

• Note •

All references to types of flight operations on the operating limitations placards are based upon equipment installed at the time of Airworthiness Certificate issuance.

System, Instrument, and/ or Equipment	Kinds of Operation				Remarks, Notes, and/or Exceptions
	VFR Day	VFR Nt.	IFR Day	IFR Nt.	
<b>Placards and Markings</b>					
Airplane Flight Manual (Included w/ POH)	1	1	1	1	
<b>Communications</b>					
VHF COM	—	—	1	1	
<b>Electrical Power</b>					
Battery 1	1	1	1	1	
Battery 2	—	—	1	1	
Alternator 1	1	1	1	1	
Alternator 2	—	—	1	1	
Amp Meter/Indication	1	1	1	1	



System, Instrument, and/ or Equipment	Kinds of Operation (Continued)				Remarks, Notes, and/or Exceptions
	VFR Day	VFR Nt.	IFR Day	IFR Nt.	
Low Volts Annunciator	1	1	1	1	
ALT 1 Annunciator	1	1	1	1	
ALT 2 Annunciator	—	—	1	1	
Circuit Breakers	A/R	A/R	A/R	A/R	As required.
<b>Equipment &amp; Furnishings</b>					
Emergency Locator Trans- mitter	1	1	1	1	
Restraint System	A/R	A/R	A/R	A/R	One seat belt for each occupant.
<b>Fire Protection</b>					
Fire Extinguisher	1	1	1	1	
<b>Flight Controls</b>					
Flap Position Indicator	1	1	1	1	
Flap System	1	1	1	1	
Pitch Trim Indicator	1	1	1	1	
Pitch Trim System	1	1	1	1	
Roll Trim Indicator	1	1	1	1	
Roll Trim System	1	1	1	1	
Stall Warning System	1	1	1	1	
<b>Fuel</b>					
Auxiliary Fuel Pump	1	1	1	1	
Fuel Quantity Indicators	2	2	2	2	
Fuel Selector Valve	1	1	1	1	

System, Instrument, and/ or Equipment	Kinds of Operation (Continued)				Remarks, Notes, and/or Exceptions
	VFR Day	VFR Nt.	IFR Day	IFR Nt.	
<b>Ice &amp; Rain Protection</b>					
Alternate Engine Air Induction System	1	1	1	1	
Alternate Static Air Source	1	1	1	1	
Pitot Heater	—	—	1	1	
<b>Landing Gear</b>					
Wheel Pants	—	—	—	—	May be removed.
<b>Lights</b>					
PFD Bezel Lighting	—	—	—	1	
PFD Backlighting	*	1	1	1	*Required if MFD Backlighting Fails. Engine Indicators Must Be Shown in Backup Mode.
MFD Bezel Lighting	—	—	—	1	
MFD Backlighting	*	1	1	1	*Required if PFD Backlighting Fails. Engine Indicators Must Be Shown in Backup Mode.
Anticollision Lights	2	2	2	2	
Instrument Lights	—	1	—	1	
Navigation Lights	—	2	—	2	
Landing Light	—	1	—	1	For hire operations.
Flash Light	—	1	—	1	

System, Instrument, and/ or Equipment	Kinds of Operation (Continued)				Remarks, Notes, and/or Exceptions
	VFR Day	VFR Nt.	IFR Day	IFR Nt.	
<b>Navigation &amp; Pitot Static</b>					
Airspeed Indicator	1	1	1	1	
Altimeter	1	1	1	1	
Magnetic Compass	1	1	1	1	
Pitot System	1	1	1	1	
Static System, Normal	1	1	1	1	
Attitude Indicator	—	—	1	1	
Clock	—	—	1	1	
Gyroscopic Directional Indication (HSI)	—	—	1	1	
Magnetometer	—	—	1	1	
Nav Radio	—	—	1	1	
PFD Airspeed Indication	—	—	1	1	
PFD Altitude Indication	—	—	1	1	
PFD Attitude Indication	—	—	1	1	
PFD Heading Indication	—	—	1	1	
PFD Slip/Skid Indication	—	—	1	1	
Turn Coordinator	—	—	1	1	
Altitude Encoder	A/R	A/R	1	1	As required per procedure.
GPS Receiver/Navigator	—	—	A/R	A/R	As required per procedure.
Marker Beacon Receiver	—	—	A/R	A/R	As required per procedure.
VHF Navigation Radio	—	—	A/R	A/R	As required per procedure.

System, Instrument, and/ or Equipment	Kinds of Operation (Continued)				Remarks, Notes, and/or Exceptions
	VFR Day	VFR Nt.	IFR Day	IFR Nt.	
Vertical Speed Indicator	—	—	—	—	
<b>Engine Indicating</b>					
Cylinder Head Temperature Indication	—	—	—	—	
Exhaust Gas Temperature Indication	—	—	—	—	
Fuel Flow Indication	1	1	1	1	
Manifold Pressure Indica- tion	1	1	1	1	
Oil Pressure Indication	1	1	1	1	
Oil Quantity Indicator (Dip- stick)	1	1	1	1	
Oil Temperature Indication	1	1	1	1	
Turbine Inlet Temperature Indication	1	1	1	1	
Engine Speed	1	1	1	1	
<b>Special Equipment</b>					
Cirrus Airframe Parachute (CAPS)	1	1	1	1	

## Icing

Flight into known icing conditions is prohibited.

## Runway Surface

This airplane may be operated on any smooth runway surface.

## Taxi Power

Maximum continuous engine speed for taxiing is 1000 RPM on flat, smooth, hard surfaces. Power settings slightly above 1000 RPM are permissible to start motion, for turf, soft surfaces, and on inclines. Use minimum power to maintain taxi speed.

## Fuel Limits

Approved Fuel ..... Aviation Grade 100 LL (Blue) or 100 (Green)

Total Fuel Capacity ..... 94.5 U.S. Gallon (358.0 L)

Total Fuel Each Tank ..... 47.25 U.S. Gallon (179.0 L)

Total Usable Fuel (all flight conditions) ..... 92.0 U.S. Gallon (348.0 L)

Maximum Allowable Fuel Imbalance ..... 10.0 U.S. Gallon (37.9 L)

The fuel pump must be set to BOOST for takeoff, climb, landing, and for switching fuel tanks.

## Altitude Limits

Maximum Takeoff Altitude ..... 10,000 Feet MSL

Maximum Operating Altitude ..... 25,000 Feet MSL

The operating rules (FAR Part 91 and FAR Part 135) require the use of supplemental oxygen at specified altitudes below the maximum operating altitude.

## Environmental Conditions

Do not operate the airplane below an outside air temperature of -40°F (-40°C).

## Maximum Occupancy

Occupancy of this airplane is limited to “4+1” persons, the pilot and four passengers. If carrying three rear seat passengers, occupants must be wearing a seat belt and shoulder harness with their hips and back firmly against the seatback as show in the following illustration. If three rear seat passengers cannot meet these requirements, occupancy is limited to four persons.

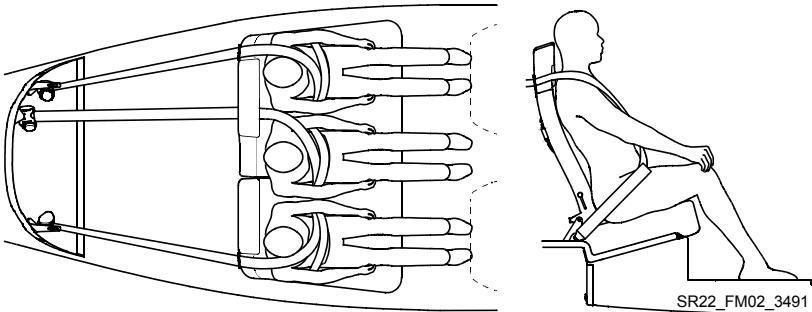

**Figure 2-2**  
**Rear Passenger Seat Arrangement**

### *Child Restraint System*

1. Rear seat configuration for LATCH / ISOFIX compliant child seats is limited to two seats in the outboard positions.
2. A single non-LATCH / ISOFIX compliant seat may be installed in the center seat position.
3. Installation of three child seats in the rear seat is prohibited.

Refer to Section 7, [Seats](#) for additional information.

## Systems and Equipment Limits

### Cirrus Perspective Integrated Avionics System

1. The appropriate revision of the Cirrus Perspective Cockpit Reference Guide (p/n 190-00821-XX, where X can be any digit from 0 to 9) must be immediately available to the pilot during flight. The system software version stated in the reference guide must be appropriate for the system software version displayed on the equipment.
2. The Avionics System integrates with separately approved sensor installations. Adherence to limitations in appropriate installation POH supplements is mandatory.
3. **IFR enroute and terminal navigation is prohibited unless the pilot verifies the currency of the database or verifies each selected waypoint for accuracy by reference to current approved data.**
4. Instrument approach navigation predicated upon the GPS Receiver must be accomplished in accordance with approved instrument approach procedures that are retrieved from the GPS equipment database. The GPS equipment database must incorporate the current update cycle.
  - a. Receiver Autonomous Integrity Monitoring (RAIM) must be available at the Final Approach Fix for instrument approach procedures that do not use the integrity information from Satellite Based Augmentation Systems (SBAS). For flight planning purposes, in areas where SBAS coverage is not available, the pilot must check RAIM availability.
  - b. Accomplishment of ILS, LOC, LOC-BC, LDA, SDF, MLS or any other type of approach not approved for GPS overlay with the GPS receiver is not authorized.
  - c. Use of the VOR/ILS receiver to fly approaches not approved for GPS require VOR/ILS navigation data to be present on the display.
  - d. Vertical Navigation information for approach procedures that do not meet the ICAO Annex 10 requirements for precision approaches may be utilized for advisory information only. Use of Vertical Navigation information for Instrument Approach Procedures does not guarantee step-down fix altitude protection, or arrival at approach minimums in normal position to land.

- e. IFR non-precision approach approval is limited to published approaches within the U.S. National Airspace System. Approaches to airports in other airspace are not approved unless authorized by the appropriate governing authority.
- f. RNAV approaches must be conducted utilizing the GPS sensor.
- g. Except when GFC 700 with system software 0764.09 or later installed, when conducting missed approach procedures, autopilot (if installed) coupled operation is prohibited until the pilot has established a rate of climb that ensures all altitude requirements of the procedure will be met.
- h. The Perspective Integrated Avionics System is compliant with AC 90-100A. As such, the Cirrus Perspective system is eligible to fly RNAV 'Q' or 'T' routes, RNAV SID/STAR/ODPs and eligible to use RNAV substitution or RNAV alternate means of navigation (US Only). Refer to AC 90-100A for additional operator requirements and limitations.
- i. The Perspective Integrated Avionics System includes navigation sensors that meet the standards set forth in TSO-C145a/ETSO-C145 (Sensors) and TSO-C146a/ETSO-C146 (Display Units) for Class 3 systems.
- j. The Perspective Integrated Avionics System has been installed in accordance with AC 20-138A and is approved for navigation using GPS and SBAS (within the coverage of a Satellite Based Augmentation System complying with ICAO annex 10) for IFR enroute, terminal and approach operations.
- k. The Perspective Integrated Avionics System complies with the standards set forth in AC 90-96A and JAA TGL-10 (rev 1) for BRNAV and PRNAV operations.
- l. The navigation databases employed by the Perspective Integrated Avionics System meet the requirements set forth in AC 20-153 for database integrity, quality and database management practices. The data in the navigation databases are referenced to the WGS-84 reference system.
- m. The Perspective Integrated Avionics System complies with the standards set forth in AMC 20-27 and NPA 2009-04 (AMC 20-28) for RNAV operations including LNAV/VNAV and LPV approach operations.



- n. *Serials w/ system software load 0764-21 or later:* Barometric vertical navigation (Baro-VNAV) operations may be conducted if SBAS is unavailable or disabled. The Perspective Integrated Avionics System will provide automatic, temperature-compensated glidepath vertical guidance and has been shown to meet the accuracy requirements of VFR/IFR enroute, terminal, and approach Baro-VNAV operations within the conterminous US and Alaska in accordance with the criteria in AC 20-138D.
5. Navigation using the Perspective Integrated Avionics System is not authorized in the following geographic areas:
  - a. north of 70°North latitude (northern polar region),
  - b. south of 70°South latitude (southern polar region),
  - c. north of the 65°North latitude between longitude 75°W and 120°W (Northern Canada),
  - d. south of 55°south latitude between longitude 120°E and 165°E (region south of Australia and New Zealand).
6. The MFD checklist display supplements the Pilot Operating Handbook checklists and is advisory only. Use of the MFD checklists as the primary set of on-board airplane checklists is prohibited.
7. The NAVIGATION MAP is intended only to enhance situational awareness. Use of the NAVIGATION MAP page for pilotage navigation is prohibited.
8. Do not use SAFETAXI or CHARTVIEW functions as the basis for ground maneuvering. SAFETAXI and CHARTVIEW functions have not been qualified to be used as an Airport Moving Map Display (AMMD). SAFETAXI and CHARTVIEW are to be used by the flight crew to orient themselves on the airport surface to improve pilot situational awareness during ground operations.
9. The TERRAIN PROXIMITY MAP is intended only to enhance situational awareness. Use of the TERRAIN PROXIMITY information for primary terrain avoidance is prohibited.
10. LTNG information on the NAVIGATION MAP or WEATHER MAP is approved only as an aid to hazardous weather avoidance. Use of the WEATHER MAP for hazardous weather penetration is prohibited.

11. The SYNTHETIC VISION SYSTEM (SVS) cannot be used for flight guidance, navigation, traffic avoidance, or terrain avoidance. Maneuvering the airplane in any phase of flight such as taxi, takeoff, approach, landing, or roll out shall not be predicated on SVS imagery. The synthetic vision system is not intended to be used independently of traditional attitude instrumentation. Consequently, SVS is disabled when traditional attitude instrumentation is not available. Otherwise, the traditional attitude instrumentation will always be visible in the foreground with SVS features in the background.
12. Use of the TRAFFIC ADVISORY SYSTEM (TAS) to maneuver the airplane to avoid traffic is prohibited. The TAS is intended for advisory use only. TAS is intended only to help the pilot to visually located traffic. It is the responsibility of the pilot to see and maneuver to avoid traffic.
13. Use of use of portable electronic devices during takeoff and landing is prohibited.

### **L-3 Skywatch Traffic Advisory System (Optional)**

1. Traffic information shown on the Perspective Integrated Avionics System displays is provided as an aid in visually acquiring traffic. Pilots must maneuver the aircraft based only upon ATC guidance or positive visual acquisition of conflicting traffic.
2. If the pilot is advised by ATC to disable transponder altitude reporting, Traffic Advisory System must be turned OFF.
3. When option installed, the appropriate revision of the L-3 Avionics Systems SkyWatch Traffic Advisory System Model SKY497 Pilot's Guide (p/n 009-10801-001) must be available to the pilot during flight.

### **L-3 Stormscope Weather Information System (Optional)**

1. Use of the Weather Information System is not intended for hazardous weather penetration (thunderstorm penetration). Weather information, as displayed on the Perspective Integrated Avionics System, is to be used only for weather avoidance, not penetration.
2. When option installed, the appropriate revision of the L-3 Avionics Systems WX500 Stormscope Series II Weather Mapping Sensor

User’s Guide, (p/n 009-11501-001) must be available to the pilot during flight.

**Max Viz Enhanced Vision System (Optional)**

1. The Enhanced Vision System (EVS) cannot be used for flight guidance, navigation, traffic avoidance, or terrain avoidance. Maneuvering the airplane in any phase of flight such as taxi, takeoff, approach, landing, or roll out shall not be predicated on EVS imagery. The EVS shall only be used as an aide to assist the flight crew to visually acquire objects normally viewed through the cockpit windows.
2. The appropriate revision of the Max Viz Enhanced Vision System Information Manual, (p/n 309100024) must be available to the pilot during flight.

**MD302 Standby Attitude Module (Optional)**

1. Selection of the option menu of the MD302 is limited to ground or visual meteorological conditions.
2. The display has an operational lower temperature limit of -22°F (-30°C). Visibility of the display may be reduced between -4°F (-20°C) and -22°F (-30°C).
3. The appropriate revision of the Mid-Continent Instruments and Avionics MD302 Standby Attitude Module Pilot’s Guide (p/n 9017846) must be available to the pilot whenever the system is in use.

**Air Conditioning System (Optional)**

The use of Recirculation Mode during flight is prohibited.

**Inflatable Restraint System**

Use of a child safety seat with the inflatable restraint system is prohibited.

**Flap Limitations**

Approved Takeoff Settings ..... UP (0%) or 50%

Approved Landing Settings ..... 0%, 50%, or 100%

Do not use flaps above 17,500 feet MSL.

## Paint

To ensure that the temperature of the composite structure does not exceed 150°F (66°C), the outer surface of the airplane must be painted in accordance with the paint colors and schemes as specified in the Airplane Maintenance Manual. Refer to Airplane Maintenance Manual (AMM), Chapter 51, for specific paint requirements.

## Cirrus Airframe Parachute System (CAPS)

VPD Maximum Demonstrated Deployment Speed.....140 KIAS

• Note •

Refer to Section 10, [Cirrus Airframe Parachute System \(CAPS\)](#) for additional CAPS guidance.

## Other Limitations

### Smoking

Smoking is prohibited in this airplane.

## Placards

*Engine compartment, inside oil filler access:*

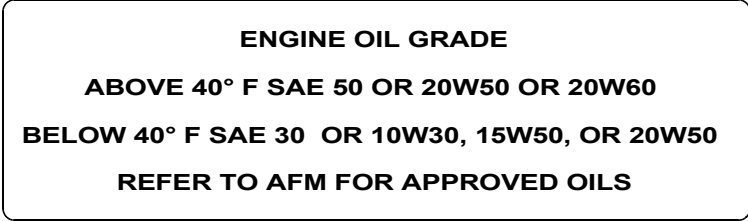

*Wing, adjacent to fuel filler caps:*

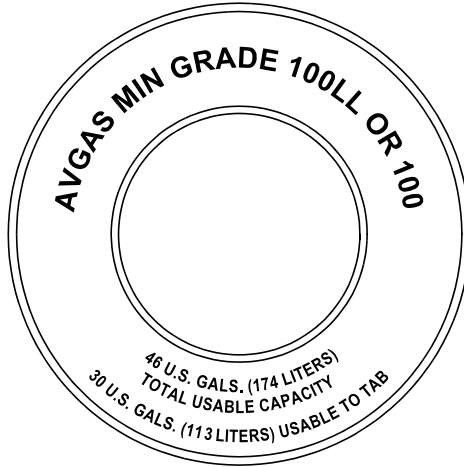

*Upper fuselage, either side of CAPS rocket cover:*

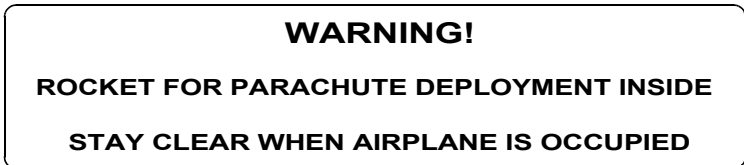

SR22\_FM02\_2680

**Figure 2-3**  
**Placards (Sheet 1 of 6)**

*Elevator and Rudder, both sides:*



*Left fuselage, on external power supply door:*

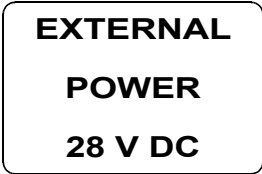

*Doors, adjacent to latch:*



*Serials 0442 thru 1232*

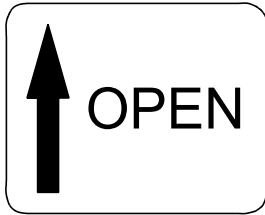

*Serials 1233 & subs*

*Wing, adjacent to fluid filler cap:*

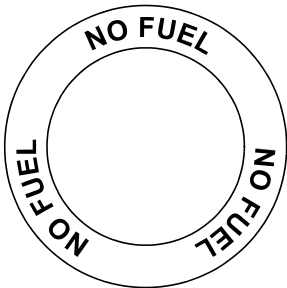

*Serials w/ Ice Protection.*

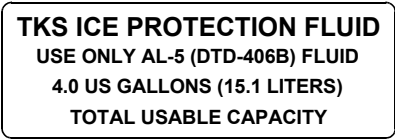

SR22\_FM02\_4258

**Figure 2-4**  
**Placards (Sheet 2 of 6)**

Engine control panel:

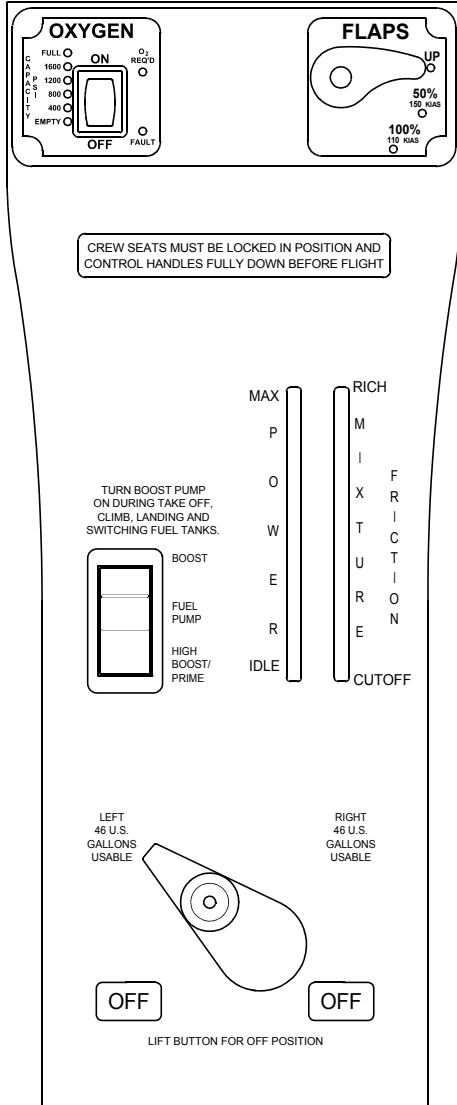

SR22\_FM02\_3559

**Figure 2-5**  
**(Sheet 3 of 6)**

*Wing, flap aft edge and fuselage vortex generator:*

**NO STEP**

*Cabin Door Window, lower edge, centered, applied upside down:*

**RESCUE: FRACTURE AND REMOVE WINDOW**

*Bolster Switch Panel, left edge:*

**THIS AIRCRAFT IS CERTIFIED FOR THE  
FOLLOWING FLIGHT OPERATIONS:  
DAY - NIGHT - VFR - IFR  
(WITH REQUIRED EQUIPMENT)  
FLIGHT INTO KNOWN ICING IS PROHIBITED  
OPERATE PER AIRPLANE FLIGHT MANUAL**

*Instrument Panel, left :*

**NORMAL CATEGORY AIRPLANE  
NO ACROBATIC MANEUVERS,  
INCLUDING SPINS, APPROVED**

---

**ABOVE 17,500  $V_{NE}$  AND  $V_{NO}$   
REDUCE LINEARLY WITH ALTITUDE:**

	$V_{NE}$	$V_{NO}$	
17,500	205	176	KIAS
25,000	175	150	KIAS

---

**MANEUVERING SPEED:  $V_o$  140 KIAS**

SR22\_FM02\_3566

**Figure 2-6  
(Sheet 4 of 6)**



*Instrument Panel, center:*



*Bolster Panel, both sides:*



*Baggage Compartment, aft edge:*



*Instrument Panel:*



*Cabin Window, above door latch:*

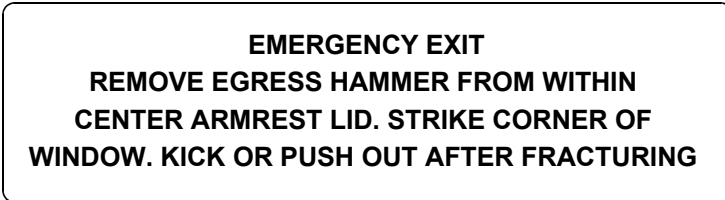

*Baggage Compartment Door, inside:*

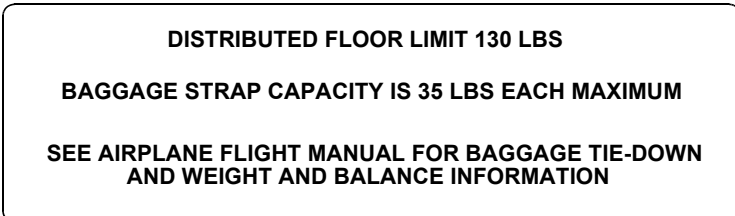

SR22\_FM02\_2684

**Figure 2-7  
(Sheet 5 of 6)**

*CAPS Deployment Handle Cover, above pilot's right shoulder:*

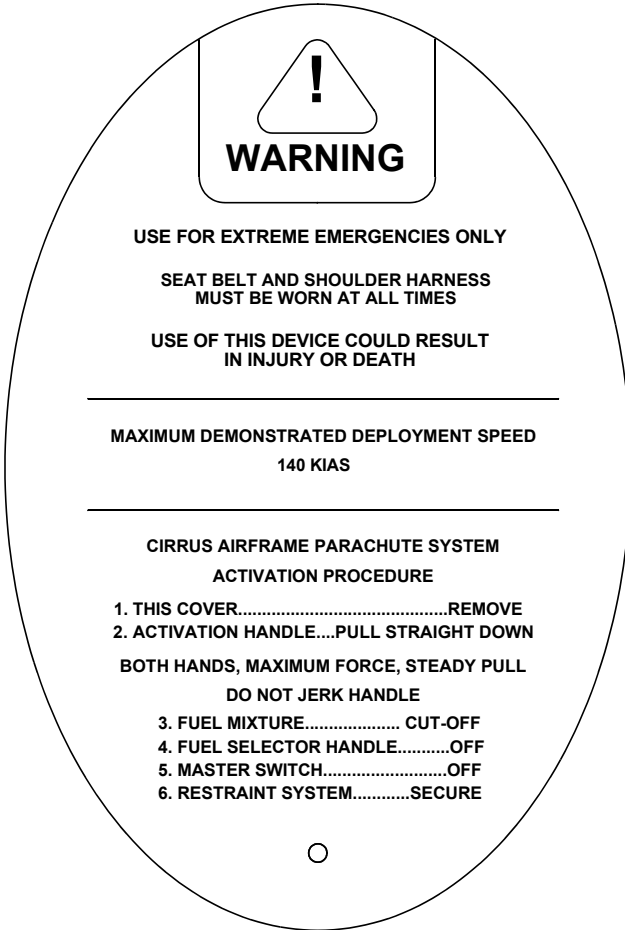

SR22\_FM02\_3567

**Figure 2-8**  
**(Sheet 6 of 6)**

# ***Section 3: Emergency Procedures***

## **Table of Contents**

Introduction .....	3
Emergency Procedures Guidance .....	4
CAPS Guidance .....	4
Preflight Planning .....	4
Preflight Inspections/Maintenance .....	4
Methodology .....	4
Circuit Breakers .....	5
Memory Items .....	6
Airspeeds for Emergency Operations .....	7
Engine Failures .....	8
Engine Failure On Takeoff (Low Altitude) .....	8
Engine Failure In Flight .....	9
Airstart .....	12
Engine Airstart .....	12
Smoke and Fire .....	13
Cabin Fire In Flight .....	13
Engine Fire In Flight .....	14
Wing Fire In Flight .....	15
Engine Fire During Start .....	15
Smoke and Fume Elimination .....	16
Emergency Descent .....	17
Emergency Descent .....	17
Maximum Glide .....	17
Forced Landing .....	18
Emergency Landing Without Engine Power .....	18
Ditching .....	19
Landing Without Elevator Control .....	19
Engine System Emergencies .....	20
Engine Partial Power Loss .....	20
Oil Pressure Out of Range .....	22
Oil Temperature High .....	22
High Cylinder Head Temperature .....	23
Turbocharger System Emergencies .....	24
Unexpected Loss Of Manifold Pressure .....	24
Manifold Pressure High .....	26
Overboost / Pressure Relief Valve .....	27

Turbine Inlet Temperature High .....	27
EGT, TIT or CHT Temperature Sensor Failure.....	28
Propeller System Emergencies .....	29
Engine Speed High .....	29
Propeller Governor Failure.....	30
Fuel System Emergencies .....	31
Low Fuel Quantity .....	31
Fuel Imbalance .....	31
Electrical System Emergencies.....	32
High Voltage on Main Bus 1 .....	32
High Voltage on Main Bus 2 .....	33
High or Low Voltage on Essential Bus.....	34
Environmental System Emergencies .....	35
Carbon Monoxide Level High.....	35
Oxygen System Emergencies .....	36
Oxygen System Fault - Above 10,000 Ft.....	36
Oxygen Quantity Low.....	37
Integrated Avionics System Emergencies.....	38
Attitude & Heading Reference System (AHRS) Failure .....	38
Air Data Computer (ADC) Failure .....	38
PFD Display Failure .....	38
Unusual Attitude Emergencies .....	39
Inadvertent Spin Entry .....	39
Inadvertent Spiral Dive During IMC Flight.....	40
Other Emergencies .....	41
Power Lever Linkage Failure .....	41
Emergency Engine Shutdown On Ground .....	41
Left/Right Brake Over-Temperature.....	42
Starter Engaged .....	42
Emergency Ground Egress.....	43
CAPS Deployment.....	44

# Fuel System Emergencies

## High Fuel Flow

### *FUEL FLOW Warning*



### ***On-Ground***

*If warning occurs during takeoff roll:*

- a. Takeoff ..... ABORT

*If warning occurs on ground, not during takeoff roll:*

- a. Power Lever ..... REDUCE
- b. Flight Operations ..... PROHIBITED

Maintenance required to reduce fuel flow.

### ***In-Flight***

- 1. Mixture Lever .... ADJUST FUEL FLOW TO TOP OF GREEN ARC
- 2. Annunciators and Engine Temperatures ..... MONITOR

### ***Amplification***

Excessively high fuel flows may lead to loss of engine power and may cause the engine to fail. If fuel flow exceeds 42 GPH, maintenance is required.

Intentionally Left Blank

## Introduction

This section provides procedures for handling emergencies and critical flight situations that may occur while operating the aircraft. Although emergencies caused by airplane, systems, or engine malfunctions are extremely rare, the guidelines described in this section should be considered and applied as necessary should an emergency arise.

• Note •

Emergency procedures associated with optional equipment are not described in this section. Refer to [Section 9: Log of Supplements](#) for optional equipment Emergency Procedures.

## Emergency Procedures Guidance

Although this section provides procedures for handling most emergencies and critical flight situations that could arise in the aircraft, it is not a substitute for proper flight training, thorough knowledge of the airplane, and general aviation techniques. A thorough study of the information in this handbook while on the ground will help you prepare for time-critical situations in the air.

### CAPS Guidance

All Cirrus aircraft are equipped with a pilot or passenger activated ballistic airframe parachute system. The system is capable of lowering the aircraft and occupants safely to the ground for life threatening emergencies. CAPS provides pilots and passengers an alternative means of handling various life threatening emergency situations. In many cases CAPS may offer a safer option for occupants as compared to continued flight or traditional countermeasures. Pilots flying Cirrus aircraft must be properly trained and familiar with CAPS guidance, limitations, and operating procedures. Refer to Section 10, [Cirrus Airframe Parachute System \(CAPS\)](#), for CAPS deployment and guidance information.

### Preflight Planning

Enroute emergencies caused by weather can be minimized or eliminated by careful flight planning and good judgment when unexpected weather is encountered.

### Preflight Inspections/Maintenance

In-flight mechanical problems in the aircraft will be extremely rare if proper preflight inspections and maintenance are practiced. Always perform a thorough walk-around [Preflight Inspection](#) before any flight to ensure that no damage occurred during the previous flight or while the airplane was on the ground. Pay special attention to any oil leaks or fuel stains that could indicate engine problems.

### Methodology

Aircraft emergencies are very dynamic events. Because of this, it is impossible to address every action a pilot might take to handle a situation. However, four basic actions can be applied to any emergency. They are:



**Maintain Aircraft Control** — Many minor aircraft emergencies turn into major ones when the pilot fails to maintain aircraft control. Remember, do not panic and do not fixate on a particular problem. Over-attention to a faulty warning light during an instrument approach can lead to a pilot induced unusual attitude and possibly worse. To avoid this, even in an emergency: aviate, navigate, and communicate, in this order. Never let anything interfere with your control of the airplane. Never stop flying.

**Analyze the Situation** — Once you are able to maintain control of the aircraft, assess the situation. Look at the engine parameters. Listen to the engine. Determine what the airplane is telling you.

**Take Appropriate Action** — In most situations, the procedures listed in this section will either correct the aircraft problem or allow safe recovery of the aircraft. Follow them and use good pilot judgment.

• Note •

In an in-flight emergency, pressing and holding the COM transfer button for 2 seconds will tune the emergency frequency of 121.500 MHz. If the display is available, it will also show it in the “Active” frequency window.

The Cirrus Airframe Parachute System (CAPS) should be activated in the event of a spin. It should also be used in other life-threatening emergencies where CAPS deployment is determined to be safer than continued flight and landing. Refer to Section 10, [Cirrus Airframe Parachute System \(CAPS\)](#) for CAPS deployment information and landing considerations.

**Land as soon as Conditions Permit** — Once you have handled the emergency, assess your next move. Handle any non-critical “clean-up” items in the checklist and put the aircraft on the ground. Remember, even if the airplane appears to be in sound condition, it may not be.

## Circuit Breakers

Many procedures involve manipulating circuit breakers. The following criteria should be followed during “Circuit Breaker” steps:

- Circuit breakers that are “SET” should be checked for normal condition. If the circuit breaker is not “Set”, it may be reset only once. If the circuit breaker opens again, do not reset.
- Circuit breakers that “PULL” should only be pulled and not reset.

- Circuit breakers that “CYCLE” should be pulled, delayed for several seconds, and reset only once. Allow sufficient cooling time for circuit breakers that are reset through a “CYCLE” procedure.

## Memory Items

Checklist steps emphasized by underlining such as the example below, should be memorized for accomplishment without reference to the procedure.

1. Best Glide Speed ..... ESTABLISH

## Airspeeds for Emergency Operations

Maneuvering Speed:

3600 lb ..... 140 KIAS

**Best Glide:**

All Weights ..... 92 KIAS

**Emergency Landing (Engine-out):**

Flaps Up ..... 90 KIAS

Flaps 50% ..... 85 KIAS

Flaps 100% ..... 80 KIAS

## Engine Failures

### Engine Failure On Takeoff (Low Altitude)

1. Best Glide or Landing Speed (as appropriate)..... ESTABLISH
2. Mixture ..... CUTOFF
3. Fuel Selector .....OFF
4. Ignition Switch .....OFF
5. Flaps ..... AS REQUIRED

*If time permits:*

6. Power Lever ..... IDLE
7. Fuel Pump..... OFF
8. Bat-Alt Master Switches .....OFF
9. Seat Belts..... ENSURE SECURED

#### **Amplification**

**• WARNING •**

If engine failure is accompanied by fuel fumes in the cockpit, or if internal engine damage is suspected, move Mixture Control to CUTOFF and do not attempt a restart.

If the engine fails immediately after becoming airborne, abort on the runway if possible. **In most cases, when the engine fails below 500 feet AGL, the landing should be made straight ahead, turning only to avoid obstructions.** In such a case, lower the nose to maintain airspeed and establish a glide attitude. **If the engine fails between 500 feet and 2000 feet AGL, CAPS activation most likely is the safest option.** After establishing a glide for landing or activating CAPS, perform as many of the checklist items as time permits.

## Engine Failure In Flight

1. Best Glide Speed ..... ESTABLISH
2. Fuel Selector ..... SWITCH TANKS
3. Ignition Switch ..... CHECK, BOTH
4. Fuel Pump ..... BOOST
5. Power Lever ..... ½ OPEN
6. Mixture ...IDLE CUTOFF then slowly ADVANCE until engine starts  
*If engine does not start:*
7. Perform CAPS Deployment or Emergency Landing Without Engine Power checklist, as required.  
*If engine starts:*
8. CHTs and Oil Temperature ..... VERIFY within GREEN range,  
warm engine at partial power if required.

### Amplification

#### • WARNING •

If engine failure is accompanied by fuel fumes in the cockpit, or if internal engine damage is suspected, move Mixture Control to CUTOFF, Fuel Selector to OFF, and do not attempt a restart.

If the engine fails at altitude, pitch as necessary to establish best glide speed. While gliding toward a suitable landing area, attempt to identify the cause of the failure and correct it. If altitude or terrain does not permit a safe landing, CAPS deployment may be required. Refer to Section 10, *Cirrus Airframe Parachute System (CAPS)* for CAPS deployment scenarios and landing considerations.

Excessive engine cooling may be experienced during long descents resulting in low engine oil and cylinder head temperatures. This may result in the engine not accelerating properly when power is reapplied. If oil or cylinder head temperatures are excessively low then the engine should be operated at partial power until the temperatures are sufficient for full power operation.

### Possible Engine Failure Causes

**Improper Fuel Management:** If the engine failure cause is determined to be improper fuel management, turn off Fuel Pump and resume flight.

**Engine Driven Fuel Pump Failure:** If fuel management is correct, failure of the engine driven fuel pump or a clogged fuel filter is probable. An engine driven fuel pump failure is probable when engine will only operate with fuel pump on HIGH BOOST/PRIME. Reduce power to 75% or less and land as soon as practical. Do not set the mixture too rich for descent or landing.

**Improper Mixture Setting:** If fuel management is correct and the engine driven fuel pump is functioning properly, it is possible the mixture is either too lean or too rich.

Possible over rich conditions:

- Very low power settings at high altitude and rich mixture.
- Very low power settings with the fuel pump on and rich mixture.
- Severe induction system blockage, leakage, or turbo failure and rich mixture.

Possible over lean conditions:

- Advancing the throttle from a lean condition before enriching the mixture
- HIGH BOOST/PRIME switched off from a lean condition before enriching the mixture.
- Vapor in fuel line (likely to happen in very hot ambient conditions at altitude).
- High altitude descent in lean condition with no corresponding throttle or mixture change.

Above 18,000 Feet

The manifold pressure should be maintained at or above 15 in.Hg (bottom of the green arc on the manifold pressure gage) when the aircraft is operating above 18,000 feet. If the manifold pressure is reduced below 15 in.Hg and the Power Lever positioned close to or at idle, the engine may cease combustion. Upon advancing the Power Lever, if the wind milling engine does not immediately regain power, the following procedure should be used:

1. Electric Fuel Pump..... LOW BOOST
2. Power Lever..... ½ OPEN
3. Mixture Control .... FULL RICH, then LEAN until engine starts then slowly advance to FULL RICH
4. Power Lever..... AS REQUIRED
5. Mixture ..... AS REQUIRED
6. Electric Fuel Pump..... AS REQUIRED

## Airstart

### Engine Airstart

1. Bat Master Switches ..... ON
2. Power Lever ..... OPEN ½ INCH
3. Mixture ..... RICH, AS REQ'D
4. Fuel Selector ..... SWITCH TANKS
5. Ignition Switch ..... BOTH
6. Fuel Pump ..... BOOST
7. Alt Master Switches ..... OFF
8. Starter (Propeller not Windmilling) ..... ENGAGE
9. Power Lever ..... slowly INCREASE
10. Alt Master Switches ..... ON
11. CHTs and Oil Temperature ..... VERIFY within GREEN range,  
warm engine at partial power if required.
12. If engine will not start, perform *Forced Landing* checklist.

#### ***Amplification***

Switching tanks and turning the fuel pump on will enhance starting if fuel contamination was the cause of the failure. Leaning the mixture and then slowly enriching mixture may correct faulty mixture control.

Engine airstarts may be performed during 1g flight anywhere within the normal operating envelope of the airplane.



## Smoke and Fire

### Cabin Fire In Flight

1. Bat-Alt Master Switches..... OFF, AS REQ'D
2. Fire Extinguisher.....ACTIVATE

*If airflow is not sufficient to clear smoke or fumes from cabin:*

3. Cabin Doors..... PARTIALLY OPEN
4. Avionics Power Switch..... OFF
5. All other switches..... OFF
6. Land as soon as possible.

*If setting master switches off eliminated source of fire or fumes and airplane is in night, weather, or IFR conditions:*

7. Airflow Selector..... OFF
8. Bat-Alt Master Switches..... ON
9. Avionics Power Switch..... ON
10. Required Systems ..... ACTIVATE one at a time
11. Temperature Selector ..... COLD
12. Vent Selector ..... FEET/PANEL/DEFROST POSITION
13. Airflow Selector..... SET AIRFLOW TO MAXIMUM
14. Panel Eyeball Outlets..... OPEN
15. Land as soon as possible.

#### **Amplification**

With Bat-Alt Master Switches OFF, engine will continue to run. However, no electrical power will be available.

If the airplane is in IMC conditions, turn ALT 1, ALT 2, and BAT 1 switches OFF. Power from battery 2 will keep the Primary Flight Display operational for approximately 30 minutes. If airplane is in day VFR conditions and turning off the master switches eliminated the fire situation, leave the master switches OFF. Do not attempt to isolate the source of the fire by checking each individual electrical component.

*(Continued on following page)*

If the cause of the fire is readily apparent and accessible, use the fire extinguisher to extinguish flames and land as soon as possible. Opening the vents or doors may feed the fire, but to avoid incapacitating the crew from smoke inhalation, it may be necessary to rid cabin of smoke or fire extinguishant.

If required to re-activate systems, pause several seconds between activating each system to isolate malfunctioning system. Continue flight to earliest possible landing with malfunctioning system off. Activate only the minimum amount of equipment necessary to complete a safe landing.

### Engine Fire In Flight

1. Mixture ..... CUTOFF
2. Fuel Pump.....OFF
3. Fuel Selector .....OFF
4. Airflow Selector .....OFF
5. Power Lever .....IDLE
6. Ignition Switch .....OFF
7. Cabin Doors .....PARTIALLY OPEN
8. Land as soon as possible.

#### ***Amplification***

If an engine fire occurs during flight, do not attempt to restart the engine.

## Wing Fire In Flight

1. Pitot Heat Switch ..... OFF
2. Navigation Light Switch ..... OFF
3. Landing Light ..... OFF
4. Strobe Light Switch ..... OFF
5. If possible, side slip to keep flames away from fuel tank and cabin.
6. Land as soon as possible.

### **Amplification**

• **Caution** •

Putting the airplane into a dive may blow out the fire. Do not exceed  $V_{NE}$  during the dive.

## Engine Fire During Start

1. Mixture ..... CUTOFF
2. Fuel Pump ..... OFF
3. Fuel Selector ..... OFF
4. Power Lever ..... ADVANCE
5. Starter ..... CRANK
6. If flames persist, perform *Emergency Engine Shutdown On Ground* and *Emergency Ground Egress* Checklists.

### **Amplification**

A fire during engine start may be caused by fuel igniting in the fuel induction system. If this occurs, attempt to draw the fire back into the engine by continuing to crank the engine.

## Smoke and Fume Elimination

1. Oxygen Masks or Cannulas ..... DON
2. Oxygen System..... ON
3. Oxygen Flow Rate ..... MAXIMUM
4. Air Conditioner (if installed).....OFF
5. Temperature Selector..... COLD
6. Vent Selector.....FEET/PANEL/DEFROST POSITION
7. Airflow Selector ..... SET AIRFLOW TO MAXIMUM  
*If source of smoke and fume is firewall forward:*
  - a. Airflow Selector.....OFF
8. Panel Eyeball Outlets.....OPEN
9. Prepare to land as soon as possible.

### **Amplification**

#### **• WARNING •**

Use Oxygen System only if flames and heat are not present.

In addition to the procedures described above, pilot and passengers should don masks and use the oxygen system at the maximum flow rate until smoke and fumes have cleared.

If smoke and/or fumes are detected in the cabin, check the engine parameters for any sign of malfunction. If a fuel leak has occurred, actuation of electrical components may cause a fire. If there is a strong smell of fuel in the cockpit, divert to the nearest suitable landing field. Perform *Forced Landing* Checklist and shut down the fuel supply to the engine once a safe landing is assured.

# Emergency Descent

## Emergency Descent

1. Power Lever..... IDLE
2. Mixture ..... AS REQUIRED
3. Airspeed..... V<sub>NE</sub> (205 KIAS)

### Amplification

**• Caution •**

If significant turbulence is expected do not descend at indicated airspeeds greater than V<sub>NO</sub> (176 KIAS)

## Maximum Glide

Conditions		Example:	
Power	OFF	Altitude	10,000 ft. AGL
Propeller	Windmilling	Airspeed	Best Glide
Flaps	0% (UP)	Glide Distance	14.2 NM
Wind	Zero		

### Best Glide Speed

92 KIAS at 3600 lb

Maximum Glide Ratio ~ 8.6 : 1

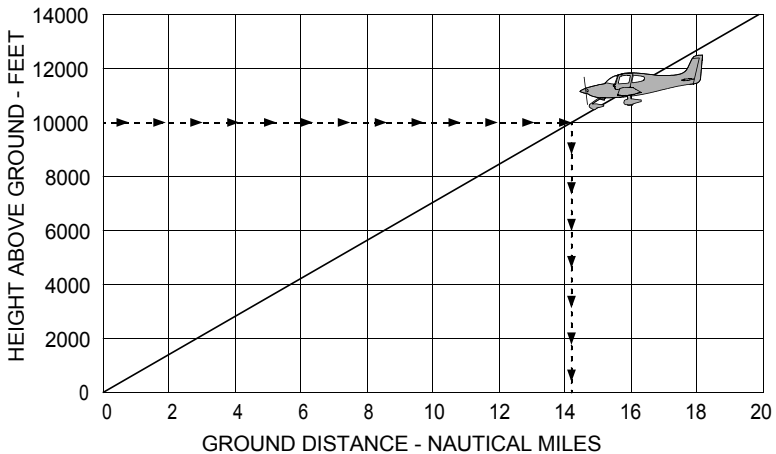

SR22\_FM03\_3564

## Forced Landing

### Emergency Landing Without Engine Power

1. Best Glide Speed ..... ESTABLISH
2. Radio.....Transmit (121.5 MHz) MAYDAY  
giving location and intentions
3. Transponder.....SQUAWK 7700
4. If off airport, ELT .....ACTIVATE
5. Power Lever.....IDLE
6. Mixture ..... CUTOFF
7. Fuel Selector.....OFF
8. Ignition Switch.....OFF
9. Fuel Pump.....OFF
10. Flaps (when landing is assured) ..... 100%
11. Master Switches..... OFF
12. Seat Belt(s) ..... SECURED

#### ***Amplification***

If all attempts to restart the engine fail and a forced landing is imminent, select a suitable field and prepare for the landing. As forced landings on unprepared surfaces are not recommended, CAPS activation may be the safest option. Refer to Section 10, *Cirrus Airframe Parachute System (CAPS)* for CAPS deployment scenarios and landing considerations.

When determined that a forced landing is the safest option, a suitable field should be chosen as early as possible so that maximum time will be available to plan and execute the forced landing. While gliding, be aware that use of flaps will reduce glide distance. Flaps should not be selected until landing is assured. Land on the main gear and hold the nose wheel off the ground as long as possible.

## Ditching

1. Radio ..... Transmit (121.5 MHz) MAYDAY  
giving location and intentions
2. Transponder..... SQUAWK 7700
3. CAPS ..... ACTIVATE
4. Airplane..... EVACUATE
5. Flotation Devices ..... INFLATE WHEN CLEAR OF AIRPLANE

### ***Amplification***

If available, life preservers should be donned and life raft should be prepared for immediate evacuation upon touchdown.

Consider unlatching a door prior to assuming the emergency landing body position in order to provide a ready escape path.

It may be necessary to allow some cabin flooding to equalize pressure on the doors. If the doors cannot be opened, break out the windows with the egress hammer and crawl through the opening.

## Landing Without Elevator Control

1. Flaps ..... SET 50%
2. Trim..... SET 80 KIAS
3. Power..... AS REQUIRED FOR GLIDE ANGLE

### ***Amplification***

The pitch trim spring cartridge is attached directly to the elevator and provides a backup should you lose the primary elevator control system. Set elevator trim for a 80 KIAS approach to landing. Thereafter, do not change the trim setting until in the landing flare. During the flare, the nose-down moment resulting from a power reduction may cause the airplane to hit on the nosewheel. At touchdown, bring the power lever to idle.

# Engine System Emergencies

## Engine Partial Power Loss

1. Air Conditioner (if installed) ..... OFF
2. Fuel Pump ..... HIGH BOOST/PRIME
3. Fuel Selector ..... SWITCH TANKS
4. Mixture ..... CHECK appropriate for flight conditions
5. Power Lever ..... SWEEP
6. Ignition Switch ..... BOTH, L, then R
7. Land as soon as practical.

### **Amplification**

#### **• WARNING •**

If there is a strong smell of fuel in the cockpit, divert to the nearest suitable landing field. Fly a forced landing pattern and shut down the engine fuel supply once a safe landing is assured.

Indications of a partial power loss include fluctuating RPM, reduced or fluctuating manifold pressure, low oil pressure, high oil temperature, and a rough-sounding or rough-running engine. Mild engine roughness in flight may be caused by one or more spark plugs becoming fouled. A sudden engine roughness or misfiring is usually evidence of a magneto malfunction.

If for any reason the aircraft experiences an unexpected loss of normal manifold pressure perform the [Unexpected Loss Of Manifold Pressure Checklist](#).

Low oil pressure may be indicative of an imminent engine failure. See [Oil Pressure Out of Range Checklist](#) in this Section for special procedures with low oil pressure.

A damaged (out-of-balance) propeller may cause extremely rough operation. If an out-of-balance propeller is suspected, immediately shut down engine and perform [Forced Landing Checklist](#).

If the power loss is due to a fuel leak in the injector system, fuel sprayed over the engine may be cooled by the slipstream airflow which may prevent a fire at altitude. However, as the Power Lever is reduced during descent and approach to landing the cooling air may not be sufficient to prevent an engine fire.



Selecting HIGH BOOST/PRIME may clear the problem if vapor in the injection lines is the problem or if the engine-driven fuel pump has partially failed. The electric fuel pump will not provide sufficient fuel pressure to supply the engine if the engine-driven fuel pump completely fails.

Selecting the opposite fuel tank may resolve the problem if fuel starvation or contamination in one tank was the problem.

Cycling the ignition switch momentarily from BOTH to L and then to R may help identify the problem. An obvious power loss in single ignition operation indicates magneto or spark plug trouble. Lean the mixture to the recommended cruise setting. If engine does not smooth out in several minutes, try a richer mixture setting. Return ignition switch to the BOTH position unless extreme roughness dictates the use of a single magneto.

If a partial engine failure permits level flight, land at a suitable airfield as soon as conditions permit. If conditions do not permit safe level flight, use partial power as necessary to set up a forced landing pattern over a suitable landing field. Always be prepared for a complete engine failure and consider CAPS deployment if a suitable landing site is not available. Refer to Section 10, [Cirrus Airframe Parachute System \(CAPS\)](#) for CAPS deployment scenarios and landing considerations.

## Oil Pressure Out of Range

### *OIL PRESS Warning*

**OIL PRESS**

1. Oil Pressure Gage ..... CHECK  
*If pressure low:*
  - a. Power ..... REDUCE to minimum for sustained flight
  - b. Land as soon as possible.
    - (1) Prepare for potential engine failure.*If pressure high:*
  - a. Power ..... REDUCE to minimum for sustained flight
  - b. Land as soon as possible.
    - (1) Prepare for potential engine failure.

### **Amplification**

If oil pressure is low, the engine has probably lost a significant amount of its oil and engine failure may be imminent.

If oil pressure is suddenly high, a blockage or obstruction may have developed in the oil circulation system and engine failure may be imminent.

## Oil Temperature High

### *OIL TEMP Warning*

**OIL TEMP**

1. Power ..... REDUCE
2. Airspeed ..... INCREASE
3. Mixture ..... ADJUST fuel flow to top of green arc
4. Oil Temperature Gage ..... MONITOR  
*If temperature remains high:*
5. Land as soon as possible.

## High Cylinder Head Temperature

### *CHT Caution and Warning*



#### ***On-Ground***

1. Power Lever..... REDUCE
2. Annunciators and Engine Temperatures ..... MONITOR  
*If Caution or Warning annunciation is still illuminated:*
3. Power Lever..... MINIMUM REQUIRED
4. Flight ..... PROHIBITED

#### ***In-Flight***

1. Power Lever..... REDUCE
2. Mixture .....ADJUST fuel flow to top of green arc
3. Airspeed .....INCREASE
4. Annunciators and Engine Temperatures ..... MONITOR  
*If Caution or Warning annunciation is still illuminated:*
5. Power Lever ..... MINIMUM REQUIRED
6. Engine Instruments ..... MONITOR  
*If Caution annunciation only remains illuminated:*
  - a. Land as soon as practical.*If Warning annunciation remains illuminated:*
  - a. Land as soon as possible.

## Turbocharger System Emergencies

### Unexpected Loss Of Manifold Pressure

1. Power .....ADJUST to minimum required for sustained flight
2. Mixture ..... ADJUST for EGTs between 1300° to 1400°F
3. Descend to MINIMUM SAFE ALTITUDE from which a landing may be safely accomplished.
4. Divert to nearest suitable airfield.
5. Radio.....Advise ATC landing is urgent or Transmit (121.5 MHz) MAYDAY giving location and intentions when workload permits.
6. Oil Pressure .....MONITOR
7. Land as soon as possible.

#### **Amplification**

If the aircraft experiences an unexpected loss of normal manifold pressure, the engine will typically revert to operation similar to a normally aspirated aircraft at approximately the same altitude. However, continued flight should only be conducted to the nearest suitable landing place in order to investigate the cause of the unexpected loss of normal manifold pressure.

The four most probable causes are:

1. A leak or rupture at an induction system coupling or a loose or failed induction coupling hose clamp.
  - a. This condition does not usually present a significant hazard, other than power loss equivalent to a naturally aspirated engine.
  - b. While this condition is the most probable, the following three conditions may present an immediate hazard to continued safe flight. Because it is difficult for the pilot to distinguish between a simple induction system leak and any of the more hazardous causes, all unexpected losses of manifold pressure should be assumed hazardous.

2. A significant leak in the exhaust system.
  - a. An exhaust leak may present a possible fire hazard. Reducing power and adjusting the mixture as described reduces the possibility of an engine compartment fire.
3. A loss of oil pressure to the wastegate actuator due to a general loss of engine oil pressure.
  - a. Potentially caused by a failed oil line, oil line fitting, or oil pump
  - b. Failure to maintain normal full manifold pressure at altitude may be an early indication of an oil leak and impending further loss of oil pressure.
  - c. Monitor for reduction in oil pressure; if observed continue for diversion airfield, but prepare for forced landing.
4. A failure of an internal component in the turbocharger.
  - a. If the pilot experiences a sudden loss of manifold pressure and later observes declining oil pressure, it is may be due to a failure of an internal turbocharger component. If there is a loss of oil pressure due to a failure of the turbocharger, engine oil may be vented through the tail pipe overboard.
  - b. Monitor for reduction in oil pressure; if observed continue for diversion airfield, but prepare for forced landing.

## Manifold Pressure High

### **MAN PRESSURE Warning**

**MAN PRESSURE**

1. Power Lever ..... REDUCE MAP to less than 36.5 in.Hg
2. Flight ..... CONTINUE

*If noticeable surging is present:*

3. Perform *Overboost / Pressure Relief Valve* Checklist.

### **Amplification**

High Manifold Pressure may be a result of cold oil and the affect of high associated oil pressure on the wastegate controller. Maintain power at or below 36.5 in.Hg by power lever management. If High Manifold Pressure persists when oil temperatures are greater than 150°F, MAP controller requires a maintenance adjustment. If engine surges are associated, MAP may be exceeding pressure relief valve (pop-off valve) threshold. Relief valve will protect induction manifolds from excessive pressure, but it may be a sign of a failed closed wastegate; if this is observed or suspected, complete the *Overboost / Pressure Relief Valve* Checklist.

## Overboost / Pressure Relief Valve

1. Power Lever.....REDUCE to 30.5 in.Hg or less
2. Mixture .....ADJUST fuel flow to top of green arc  
*If continued surging is present:*
3. Land as soon as practical.

### **Amplification**

Although it is an unlikely failure mode, the wastegate may be stuck in a closed position. If pressure relief valve is obviously surging (cycling high manifold pressure followed by sudden drop to lesser pressure, may be accompanied by "pop" noise), it may be evidence of MAP controller setting problem but may also be evidence of a seized wastegate. Engine will be adequately protected by the pressure relief valve, but turbo overspeed may result in turbo failure if pressure relief valve remains OPEN. Reducing manifold pressure (via power lever) will decrease the airflow through the engine, thereby reducing the energy available to drive the turbine; enriching the mixture will maintain lower turbine temperatures. It is unnecessary to descend prematurely, lower altitudes (higher density air) may aggravate the condition.

## Turbine Inlet Temperature High

### **TIT Warning**



1. Mixture ..... ADJUST Fuel Flow to Top of Green Arc
2. Ignition Switch..... CHECK on BOTH  
*If TIT remains in excess of limits:*
  - a. Power .....REDUCE
  - b. Land as soon as practical.

### **Amplification**

Annunciation indicates that one or both turbochargers are exceeding turbine inlet temperature limits, condition can be reduced and controlled by mixture management but may be a sign of improper combustion or magneto failure.

## EGT, TIT or CHT Temperature Sensor Failure

1. Similar gages ..... MONITOR
2. Flight ..... CONTINUE  
using remaining gages as representative.

### ***Amplification***

Isolated red X presentation of an EGT, TIT or CHT indicates that sensor has failed. Continued flight is permitted, using the remaining gages as representative of the failed gage; control airspeed or mixture in a normal manner to maintain the other cylinders or TIT within their normal operating ranges.



# Propeller System Emergencies

## Engine Speed High

### *RPM Warning: Engine Speed High*



1. Power Lever.....REDUCE by 2 in.Hg Manifold Pressure  
*If governor is not in control (RPM reduces and remains lower after power adjustment):*
2. Perform *Propeller Governor Failure* Checklist.  
*If governor is in control (RPM remains high, but stable after power reduction):*
3. Power Lever..REDUCE below 34 in.Hg for climb, below 30.5in.Hg for cruise.  
*If governed engine speed exceeds 2600 RPM:*
4. Perform *Propeller Governor Failure* Checklist.  
*If governed engine speed is 2600 RPM or less:*
5. Flight..... CONTINUE

### **Amplification**

Propeller governor is set in a fixed position, governed RPM is not directly influenced by cabin controls. If propeller speed remains stable after power lever is initially reduced (some over/undershoot normal as governor adjusts blade angle), governor is functioning normally but is governing at too high a speed. If propeller speed does vary directly with power (or airspeed), behaving like a fixed pitch propeller, propeller governing system has failed and should be addressed by *Propeller Governor Failure* Checklist.

If governor is functional and sustaining high RPM, reducing manifold pressure will decrease the engine loads and stress. Governor will require maintenance adjustment.

## Propeller Governor Failure

1. Power Lever .... Reduce to minimum necessary for sustained flight
2. Airspeed ..... Reduce to 85-90 KIAS
3. Oil Pressure ..... MONITOR
4. Land as soon as possible.

### ***Amplification***

An in-flight governor failure will likely result in a large exceedance (3000 RPM or more), as propeller blade angle will be go to fine pitch. Failure may evidence of engine oil pressure of volume loss, typically accompanied by OIL PRESSURE warning.

Propeller becomes a fixed pitch propeller; reducing speed to 85-90 KIAS and using only power necessary for sustained flight at that speed will minimize the overspeed.

# Fuel System Emergencies

## Low Fuel Quantity

### *FUEL QTY Warning*

FUEL QTY

1. Fuel Quantity Gages ..... CHECK  
*If fuel quantity indicates less than or equal to 9 gallons:*
  - a. Land as soon as practical.*If fuel quantity indicates more than 9 gallons:*
  - a. Flight..... CONTINUE, MONITOR

### **Amplification**

Annunciation indicates fuel totalizer quantity is less than or equal to 9 gallons.

## Fuel Imbalance

### *FUEL IMBALANCE Warning*

FUEL IMBALANCE

1. Fuel Quantity Gages ..... CHECK
2. Fuel Pump ..... BOOST  
*If HIGH BOOST already in use for vapor suppression, pump should be left in this position for tank switch.*
3. Fuel Selector..... SELECT FULLEST TANK
4. Fuel Pump ..... AS REQUIRED  
*After switching tanks, message will remain until sensed imbalance is less than 12 gallons.*

### **Amplification**

Fuel level imbalance (between left and right) is greater than 12 gallons.

# Electrical System Emergencies

## High Voltage on Main Bus 1

### *M BUS 1 Warning*



1. ALT 1 Master Switch ..... CYCLE
2. M Bus 1 Voltage (M1)..... CHECK  
*If M Bus 1 Voltage is greater than 32 volts.*
3. ALT 1 Master Switch ..... OFF
4. Perform *ALT 1 Caution (Failure)* Checklist (do not reset alternator)

### **Amplification**

Main Bus 1 Voltage is excessive, indicates an alternator 1 voltage regulator failure; will typically be associated with abnormally high voltage indications on M1, M2 and ESS busses, may also be associated with M Bus 2 or ESS BUS Warning message.

## High Voltage on Main Bus 2

### *M BUS 2 Warning*



1. Main Bus 1 Voltage (M1)..... CHECK  
*If M Bus 1 Voltage is greater than 32 Volts:*
2. Perform *M BUS 1 Warning* Checklist
3. Main Bus 2 Voltage (M2)..... CHECK  
*If M Bus 2 Voltage is greater than 32 Volts:*
4. ALT 2 Master Switch ..... CYCLE
5. Main Bus 2 Voltage (M2)..... CHECK  
*If M Bus 2 Voltage remains greater than 32 Volts:*
6. ALT 2 Master Switch ..... OFF
7. Perform *ALT 2 Caution (Failure)* Checklist (do not reset alternator)

### **Amplification**

Main Bus 2 Voltage is excessive. Indicates an alternator voltage regulator failure; will typically be associated with abnormally high bus voltage indications on M2 and ESS, may also be associated with M BUS 1 and ESS BUS Warning Messages.

## High or Low Voltage on Essential Bus

### *ESS BUS Warning*



1. Essential Bus Voltage (ESS)..... CHECK  
*If Essential Bus Voltage is greater than 32 Volts:*
2. Main Bus 1 and Main Bus 2 Voltages (M1 and M2)..... CHECK
3. Perform appropriate *M BUS 1 Warning* or *M BUS 2 Warning* Checklists.  
*If Essential Bus Voltage is less than 24.5 Volts:*
4. Perform *ALT 1 Caution (Failure)* and *ALT 2 Caution (Failure)* Checklists  
*If unable to restore at least one alternator:*
5. Non-Essential Loads.....REDUCE
  - a. If flight conditions permit, consider shedding:  
*Air Conditioning, Landing Light, Pitot Heat, Cabin Fan, Nav Lights, Strobe Lights, Audio Panel, COM 2, Yaw Damper*
6. Land as soon as practical (Battery reserve only).

### **Amplification**

#### **• Caution •**

Dependant on battery state, flaps and landing light may be unavailable on landing.

Essential Bus voltage is high or low. High voltage indicates alternator voltage regulator failure; will typically be associated with high M1 and/or M2 voltages and M BUS 1 and/or M BUS 2 warning messages.

Low voltage indicates dual failures of Alternators 1 and 2, will typically be associated with low M1 and M2 voltages, M BUS 1 and M BUS 2 Caution messages, and Alt 1 and Alt 2 Caution messages.

# Environmental System Emergencies

## Carbon Monoxide Level High

### *CO LVL HIGH Warning*

CO LVL HIGH

1. Air Conditioner (if installed)..... NOT IN RECIRC MODE
2. Temperature Selector ..... COLD
3. Vent Selector ..... FEET/PANEL/DEFROST POSITION
4. Airflow Selector ..... SET AIRFLOW TO MAXIMUM
5. Panel Eyeball Outlets..... OPEN  
*If CO LVL HIGH does not extinguish:*
6. Supplemental Oxygen (if available).
  - a. Oxygen Masks or Cannulas ..... DON
  - b. Oxygen System ..... ON
  - c. Oxygen Flow Rate ..... MAXIMUM
7. Land as soon as possible.

### **Amplification**

Annunciation indicates carbon monoxide level is greater than 50 PPM. Ensure that air condition is not in recirculate mode and that air temperature is set to full COLD to supply maximum amount of fresh air to cabin.

## Oxygen System Emergencies

### Oxygen System Fault - Above 10,000 Ft

#### *OXYGEN FAULT Warning*

**OXYGEN FAULT**

1. Oxygen Flow Rate ..... CHECK  
*If no flow:*
2. Initiate Emergency Descent to below 10,000 ft:
  - a. Power Lever ..... IDLE
  - b. Mixture ..... AS REQUIRED
  - c. Airspeed ..... VNE (205 KIAS)*If flow is normal:*
3. Oxygen Flow Rate ..... MONITOR
4. Initiate Normal Descent as soon as practical.  
*Below 10,000 ft:*
5. Oxygen System ..... OFF
6. Flight ..... CONTINUE  
Remain below altitudes requiring supplemental oxygen.

#### **Amplification**

Annunciation indicates tank solenoid failed (open or closed) or flow rate is low. If flow is checked and confirmed present, solenoid has failed OPEN; system will continue to provide oxygen until depleted, but unnecessary flight at altitudes requiring oxygen is not recommended.



## Oxygen Quantity Low

### *OXYGEN QTY Warning*

OXYGEN QTY

1. Oxygen Pressure and Flow Rate ..... CHECK
2. Initiate Normal Descent (non-emergency) below 10,000 ft.
3. Oxygen Flow Rate ..... MONITOR  
*Below 10,000 ft:*
4. Flight ..... CONTINUE  
Remain below altitudes requiring supplemental oxygen.

### ***Amplification***

1. Annunciation indicated tank pressure is below 400 PSI, see Oxygen Duration Table of the Oxygen AFMS to determine duration.

## Integrated Avionics System Emergencies

A “Red X” through any electronic display field, such as COM frequencies, NAV frequencies, or engine data, indicates that display field is not receiving valid data.

### Attitude & Heading Reference System (AHRS) Failure

1. Verify Avionics System has switched to functioning AHRS  
*If not, manually switch to functioning AHRS and attempt to bring failed AHRS back on-line:*
2. Failed AHRS Circuit Breaker .....SET  
*If open, reset (close) circuit breaker. If circuit breaker opens again, do not reset.*
3. Be prepared to revert to Standby Instruments (Altitude, Heading).

#### Amplification

Failure of the Attitude and Heading Reference System (AHRS) is indicated by removal of the sky/ground presentation and a “Red X” and a yellow “ATTITUDE FAIL” shown on the PFD. The digital heading presentation will be replaced with a yellow “HDG” and the compass rose digits will be removed. The course pointer will indicate straight up and course may be set using the digital window.

### Air Data Computer (ADC) Failure

1. ADC Circuit Breaker .....SET  
*If open, reset (close) circuit breaker. If circuit breaker opens again, do not reset.*
2. Revert to Standby Instruments (Altitude, Airspeed).
3. Land as soon as practical.

#### Amplification

Complete loss of the Air Data Computer is indicated by a “Red X” and yellow text over the airspeed, altimeter, vertical speed, TAS and OAT displays. Some FMS functions, such as true airspeed and wind calculations, will also be lost.

### PFD Display Failure

1. Display Backup .....ACTIVATE
2. Land as soon as practical.

# Unusual Attitude Emergencies

## Inadvertent Spin Entry

1. CAPS .....ACTIVATE

### ***Amplification***

**• WARNING •**

In all cases, if the aircraft enters an unusual attitude following or in connection with a stall, a spin condition should be assumed and, ***immediate*** deployment of the CAPS is required. Under no circumstances should spin recovery other than CAPS deployment be attempted.

The aircraft is not approved for spins, and has not been certified for traditional spin recovery characteristics. The only approved and demonstrated method of spin recovery is activation of the Cirrus Airframe Parachute System (see [CAPS Deployment](#) Checklist, this section). Because of this, if the aircraft enters a spin, CAPS must be deployed immediately.

While the stall characteristics of the aircraft make inadvertent entry into a spin extremely unlikely, it is possible. Spin entry can be avoided by using good airmanship: coordinated use of controls in turns, proper airspeed control following the recommendations of this Handbook, and never abusing the flight controls with aggressive inputs when close to the stall (see Section 4, [Stalls](#) discussion).

If, at the stall, the controls are misapplied and abused aggressive inputs are made to the elevator, rudder and/or ailerons, an abrupt wing drop may be felt and a spin may be entered.

## Inadvertent Spiral Dive During IMC Flight

1. Power Lever..... IDLE
2. Stop the spiral dive by using coordinated aileron and rudder control while referring to the attitude indicator and turn coordinator to level the wings.
3. Cautiously apply elevator back pressure to bring airplane to level flight attitude.
4. Trim for level flight.
5. Set power as required.
6. Use autopilot if functional otherwise maintain a constant heading through the coordinated aileron and rudder inputs.
7. Exit IMC conditions as soon as possible.

### **Amplification**

In all cases, if the aircraft enters an unusual attitude from which recovery is not assured, immediately deploy CAPS. Refer to Section 10, *Cirrus Airframe Parachute System (CAPS)* for CAPS deployment information.

## Other Emergencies

### Power Lever Linkage Failure

1. Power Lever Movement..... VERIFY
2. Power..... SET if able
3. Flaps..... SET if needed
4. Mixture.....AS REQUIRED (full rich to cut-off)
5. Land as soon as possible.

#### ***Amplification***

If the Power Lever linkage fails in flight, the engine will not respond to power lever control movements. Use power available and flaps as required to safely land the airplane.

If the power lever is stuck at or near the full power position, proceed to a suitable airfield. Fly a forced landing pattern. With landing assured, shut down engine by moving mixture control full aft to CUTOFF. If power is needed again, return mixture control to full RICH and regain safe pattern parameters or go-around. If airspeed cannot be controlled, shut engine down and perform the *Forced Landing Checklist*. After landing, bring the airplane to a stop and complete the *Emergency Engine Shutdown On Ground Checklist*.

If the power lever is stuck at or near the idle position and straight and level flight cannot be maintained, establish glide to a suitable landing surface. Fly a forced landing pattern.

### Emergency Engine Shutdown On Ground

1. Power Lever..... IDLE
2. Fuel Pump (if used) .....OFF
3. Mixture.....CUTOFF
4. Fuel Selector.....OFF
5. Ignition Switch.....OFF
6. Bat-Alt Master Switches.....OFF

## Left/Right Brake Over-Temperature

### ***BRAKE TEMP Warning***



1. Stop aircraft and allow the brakes to cool.

### ***Amplification***

Annunciation indicates brake temperature is greater than 293°F. Refer to Section 10, *Taxiing, Steering, and Braking Practices* for additional information

## Starter Engaged

### ***STARTER ENGAGED Warning***



### ***On-Ground***

1. Ignition Switch ..... DISENGAGE
2. Battery Switches ..... Wait 1 minute before next start attempt.  
*If starter does not disengage (relay or solenoid failure):*
3. BAT 1 Switch ..... OFF
4. Engine ..... SHUTDOWN
5. STARTER Circuit breaker ..... PULL

### ***In-Flight***

1. Ignition Switch ..... Ensure not stuck in START
2. STARTER Circuit breaker ..... PULL
3. Flight ..... CONTINUE  
Engine start will not be available at destination.

*(Continued on following page)*

***Amplification***

**• WARNING •**

Use caution after shutdown if STARTER circuit breaker required pull (failed relay or solenoid). If breaker is unknowingly or unintentionally reset, starter will instantly engage if Battery 1 power is supplied; creating a hazard for ground personnel.

Starter has been engaged for more than 15 seconds (starter limit is 10 seconds); if not manually engaged, such as during difficult start, this annunciation may indicate a failure of the starter solenoid or a stuck keyswitch.

**Emergency Ground Egress**

1. Engine..... SHUTDOWN
2. Seat belts ..... RELEASE
3. Airplane..... EXIT

***Amplification***

**• WARNING •**

While exiting the airplane, make sure evacuation path is clear of other aircraft, spinning propellers, and other hazards.

If the engine is left running, set the Parking Brake prior to evacuating the airplane.

If the doors cannot be opened, break out the windows with egress hammer, located in the console between the front seats, and crawl through the opening.

## CAPS Deployment

• **WARNING** •

The maximum demonstrated deployment speed is 140 KIAS.

1. Activation Handle Cover ..... REMOVE
2. Activation Handle (Both Hands)..... PULL STRAIGHT DOWN

*After Deployment as time permits:*

3. Mixture ..... CUTOFF
4. Fuel Selector ..... OFF
5. Fuel Pump ..... OFF
6. Bat-Alt Master Switches ..... OFF  
Turn the Bat-Alt Master Switches off after completing any necessary radio communications.
7. Ignition Switch ..... OFF
8. ELT ..... ON
9. Seat Belts and Harnesses ..... TIGHTEN
10. Loose Items ..... SECURE
11. Assume emergency landing body position.
12. After the airplane comes to a complete stop, evacuate quickly and move upwind.

### ***Amplification***

• **WARNING** •

Jerking or rapidly pulling the activation T-handle will greatly increase the pull forces required to activate the rocket. Use a firm and steady pulling motion – a “chin-up” type pull ensures successful activation.

The Cirrus Airframe Parachute System (CAPS) should be activated immediately in the event of a spin. It should also be used in other life-threatening emergencies where CAPS deployment is determined to be safer than continued flight and landing.



Expected impact in a fully stabilized deployment is equivalent to a drop from approximately 13 feet.

• **Caution** •

CAPS deployment will likely result in damage or loss to the airframe.

Several possible scenarios in which the activation of the CAPS would be appropriate are discussed in [Section 10: Safety Information](#) of this Handbook. These include:

- Mid-air collision
- Structural failure
- Loss of control
- Landing on an unprepared surface
- Pilot incapacitation

All pilots should carefully review the information on CAPS activation and deployment in Section 10 before operating the airplane.

CAPS Deployment at High Altitudes

For any indicated airspeed, as altitudes increase the true air speed of the deployment increases. Higher true air speeds increase the parachute inflation loads. Therefore, it is important for the operator takes all reasonable efforts to slow to the minimum possible airspeed prior to deploying the CAPS.

Intentionally Left Blank

# ***Section 3A: Abnormal Procedures***

## **Table of Contents**

Introduction .....	3
Abnormal Procedures Guidance .....	4
Circuit Breakers .....	4
Flight Environment .....	5
Inadvertent Icing Encounter .....	5
Inadvertent IMC Encounter .....	5
Door Open In Flight .....	5
Abnormal Landings .....	6
Landing With Failed Brakes .....	6
Landing With Flat Tire .....	6
Engine System .....	7
Low Idle Oil Pressure .....	7
Manifold Pressure High .....	7
Starter Engaged .....	8
Alternate Air Door Open Annunciation .....	9
Fuel System .....	10
Low Fuel Quantity .....	10
Left Fuel Tank Quantity .....	10
Right Fuel Tank Quantity .....	10
Fuel Imbalance .....	11
Electrical System .....	12
Low Voltage on Main Bus 1 .....	12
Low Voltage on Main Bus 2 .....	12
Battery 1 Current Sensor .....	12
Low Alternator 1 Output .....	13
Low Alternator 2 Output .....	14
Integrated Avionics System .....	15
Avionics Switch Off .....	15
PFD Cooling Fan Failure .....	15
MFD Cooling Fan Failure .....	15
Flight Displays Too Dim .....	16
Pitot Static System .....	17
Pitot Static Malfunction .....	17
Pitot Heat Current Sensor Annunciation .....	18
Pitot Heat Required Annunciation .....	18
Flight Control System .....	19

**Section 3A**  
**Abnormal Procedures**

**Cirrus Design**  
**SR22T**

Electric Trim/Autopilot Failure .....	19
Flap System Exceedance .....	19
Landing Gear System .....	20
Brake Failure During Taxi .....	20
Left/Right Brake Over-Temperature.....	20
Oxygen System .....	21
Oxygen Quantity Low.....	21
Other Conditions .....	23
Aborted Takeoff .....	23
Parking Brake Engaged Annunciation .....	24
Communications Failure .....	24

## Introduction

This section provides procedures for handling abnormal system and/or flight conditions which, if followed, will maintain an acceptable level of airworthiness or reduce operational risk. The guidelines described in this section are to be used when an abnormal condition exists and should be considered and applied as necessary.

**• Caution •**

If a Warning annunciation is illuminated in combination with any of the following Abnormal annunciations, the Warning annunciation takes precedence and shall be performed first.

## Abnormal Procedures Guidance

Although this section provides procedures for handling most abnormal system and/or flight conditions that could arise in the aircraft, it is not a substitute for thorough knowledge of the airplane and general aviation techniques. A thorough study of the information in this handbook while on the ground will help you prepare for time-critical situations in the air.

Sound judgment as well as thorough knowledge of the aircraft, its characteristics, and the flight manual procedures are essential in the handling of any abnormal system and/or flight condition. In addition to the outlined items in the Abnormal Procedures, the following steps are considered part of all abnormal situations:

- ***Maintain Aircraft Control***
- ***Analyze the Situation***
- ***Take Appropriate Action***

### Circuit Breakers

Many procedures involve manipulating circuit breakers. The following criteria should be followed during “Circuit Breaker” steps:

- Circuit breakers that are “SET” should be checked for normal condition. If the circuit breaker is not “Set”, it may be reset only once. If the circuit breaker opens again, do not reset.
- Circuit breakers that “PULL” should only be pulled and not reset.
- Circuit breakers that “CYCLE” should be pulled, delayed for several seconds, and reset only once. Allow sufficient cooling time for circuit breakers that are reset through a “CYCLE” procedure.

## Flight Environment

### Inadvertent Icing Encounter

1. Pitot Heat .....ON
2. Exit icing conditions. Turn back or change altitude.
3. Cabin Heat .....MAXIMUM
4. Windshield Defrost..... FULL OPEN

#### ***Amplification***

Flight into known icing conditions is prohibited.

Alternate induction air door will automatically open if required.

### Inadvertent IMC Encounter

1. Airplane Control ..... ESTABLISH straight and level flight
2. Autopilot..... ENGAGE to hold heading and altitude
3. Heading ..... RESET to initiate 180° turn

#### ***Amplification***

Upon entering IMC, a pilot who is not completely proficient in instrument flying should rely upon the autopilot to execute a 180° turn to exit the conditions. Immediate action should be made to turn back as described above:

### Door Open In Flight

1. Airplane Control ..... MAINTAIN

#### ***Amplification***

The doors on the airplane will remain 1-3 inches open in flight if not latched. If this is discovered on takeoff roll, abort takeoff if practical. If already airborne do not allow efforts to close the door interfere with the primary task of maintaining control of the airplane.

## Abnormal Landings

### Landing With Failed Brakes

#### ***One brake inoperative***

1. Land on the side of runway corresponding to the inoperative brake.
2. Maintain directional control using rudder and working brake.

#### ***Both brakes inoperative***

1. Divert to the longest, widest runway with the most direct headwind.
2. Land on downwind side of the runway.
3. Use the rudder for obstacle avoidance.
4. Perform *Emergency Engine Shutdown On Ground* Checklist.

#### ***Amplification***

Rudder effectiveness will decrease with decreasing airspeed.

### Landing With Flat Tire

#### ***Main Gear***

1. Land on the side of the runway corresponding to the good tire.
2. Maintain directional control with the brakes and rudder.
3. Do not taxi. Stop the airplane and perform a normal Engine *Shutdown*.

#### ***Nose Gear***

1. Land in the center of the runway.
2. Hold the nosewheel off the ground as long as possible.
3. Do not taxi. Stop the airplane and perform a normal Engine *Shutdown*.

#### ***Amplification***

If a flat tire or tread separation occurs during takeoff and you cannot abort, land as soon as conditions permit.



# Engine System

## Low Idle Oil Pressure

### *OIL PRESS Caution*



1. If In-Flight..... LAND AS SOON AS PRACTICAL

### ***Amplification***

Oil pressure between 10 psi and 30 psi at or above 1000 RPM

This message will appear prior to engine start and should clear after engine start.

## Manifold Pressure High

### *MAN PRESSURE Caution*



1. Power Lever..... REDUCE to less than 36.5"
2. Flight..... CONTINUE

*If noticeable surging is present:*

3. Complete *Overboost / Pressure Relief Valve* Emergency Checklist

### ***Amplification***

Manifold Pressure has exceeded caution limits. High Manifold Pressure may be a result of cold oil and the affect of high associated oil pressure on the wastegate controller. Maintain power at or below 36.5" by power lever management. If High Manifold Pressure persists when oil temperatures are greater than 150°F, MAP controller requires a maintenance adjustment. If engine surges are associated, MAP may be exceeding pressure relief valve (pop-off valve) threshold. Relief valve will protect induction manifolds from excessive pressure, but it may be a sign of a failed closed wastegate; if this is observed or suspected, complete the *Overboost / Pressure Relief Valve* Emergency Checklist.

## Starter Engaged

### **STARTER ENGAGED Caution**



#### **On-Ground**

1. Ignition Switch..... DISENGAGE prior to 10 Seconds
2. Battery Switches ..... Wait 20 seconds before next start attempt  
*If starter does not disengage (relay or solenoid failure):*
3. BAT 1 Switch.....OFF
4. Engine.....SHUTDOWN
5. STARTER Circuit breaker .....PULL

#### **In-Flight**

1. Ignition Switch.....Ensure not stuck in START
2. STARTER Circuit breaker .....PULL
3. Flight ..... CONTINUE  
Engine start will not be available at destination.

#### **Amplification**

**• WARNING •**

Use caution after shutdown if STARTER circuit breaker required pull (failed relay or solenoid). If breaker is unknowingly or unintentionally reset, starter will instantly engage if Battery 1 power is supplied; creating a hazard for ground personnel.

Starter has been engaged for more than 15 seconds (starter limit is 10 seconds); if not manually engaged, such as during difficult start, this annunciation may indicate a failure of the starter solenoid or a stuck keyswitch.

## Alternate Air Door Open Annunciation

### **ALT AIR OPEN Caution**

ALT AIR OPEN

1. Manifold Pressure ..... CHECK  
*If environment suspect as cause (icing or visible debris):*
2. Flight Conditions .....CHANGE/EXIT
3. Power..... Reduce to 30.5 in.Hg when practical
4. Flight ..... CONTINUE

### **Amplification**

Alternate induction door has automatically opened, indicating an obstructed air filter. Potential environmental causes are ice contamination (icing conditions) or particles (visible debris, heavy bugs, smoke or ash).

- If ice contamination was cause, unfiltered air won't pose an operating hazard for the engine, but conditions significant enough to ice obstruct filters are not suitable conditions for long duration flight of light aircraft.
- If flying through conditions that have obvious debris contamination sources, exit those conditions as able; engine induction is unfiltered when alternate air door is open.
- Reduction to cruise power when able will reduce engine air consumption, and likely close the alternate air door (restoring filter protection to induction air).
- Filters likely require maintenance.

When alternate induction door is open, expect 3-5% power loss due to increased manifold air temperatures and expect lower critical altitude in climb. Percent Power indication will be accurate, reflecting actual (reduced) power.

# Fuel System

## Low Fuel Quantity

### FUEL QTY Caution

FUEL QTY

1. Fuel Quantity Gages ..... CHECK  
*If left & right fuel quantities indicate less than or equal to 14 gallons per side:*
  - a. Land as soon as practical.  
*If left & right fuel quantities indicate more than 14 gallons per side:*
    - a. Flight..... CONTINUE, MONITOR

### Amplification

Annunciation indicates measured/sensed fuel quantity for both tanks is less than or equal to 14 gallons per side.

## Left Fuel Tank Quantity

### L FUEL QTY Advisory

L FUEL QTY

1. Left Fuel Quantity Gage ..... CHECK  
*If left fuel quantity indicates less than or equal to 14 gallons:*
  - a. Flight..... CONTINUE, MONITOR

## Right Fuel Tank Quantity

### R FUEL QTY Advisory

R FUEL QTY

1. Right Fuel Quantity Gage ..... CHECK  
*If right fuel quantity indicates less than or equal to 14 gallons:*
  - a. Flight..... CONTINUE, MONITOR

### Amplification

Fuel quantity is less than or equal to 14 gallons.

## Fuel Imbalance

### **FUEL IMBALANCE Caution**

<b>FUEL IMBALANCE</b>
-----------------------

1. Fuel Quantity Gages ..... CHECK
2. Fuel Pump ..... BOOST  
*If HIGH BOOST already in use for vapor suppression, pump should be left in this position for tank switch.*
3. Fuel Selector ..... SELECT FULLEST TANK
4. Fuel Pump ..... AS REQUIRED  
*After switching tanks, message will remain until sensed imbalance is less than 10 gallons.*

#### **Amplification**

Fuel level imbalance (between left and right) is greater than 10 gallons.

### **FUEL IMBALANCE Advisory**

<b>FUEL IMBALANCE</b>
-----------------------

1. Fuel Quantity Gages ..... CHECK
2. Fuel Pump ..... BOOST  
*If HIGH BOOST already in use for vapor suppression, pump should be left in this position for tank switch.*
3. Fuel Selector ..... SELECT FULLEST TANK
4. Fuel Pump ..... AS REQUIRED  
*After switching tanks, message will remain until sensed imbalance is less than 8 gallons.*

#### **Amplification**

Fuel level imbalance (between left and right) is greater than 8 gallons.

# Electrical System

## Low Voltage on Main Bus 1

### *M BUS 1 Caution*



1. Perform *ALT 1 Caution (Failure)* Checklist.

### **Amplification**

Main Bus 1 Voltage is low, indicates Alt 1 failure; will typically be associated with low M1 voltage Alt 1 current indications, Battery 1 discharge and ALT 1 Caution message.

## Low Voltage on Main Bus 2

### *M BUS 2 Caution*



1. Perform *ALT 1 Caution (Failure)* and *ALT 2 Caution (Failure)* Checklists.

### **Amplification**

Main Bus 2 Voltage is low, indicative of dual Alt 1 and 2 failures; will typically be associated with low M1 and M2 voltages, Alt 1 and Alt 2 current indications, Battery 1 discharge, ALT 1 & 2 and M BUS 1 & 2 Caution messages, and ESS BUS Warning message.

## Battery 1 Current Sensor

### *BATT 1 Caution*



1. Main Bus 1, 2 and Non-Essential Bus Loads.....REDUCE
2. Main Bus 1, 2 and Essential Bus Voltages.....MONITOR
3. Land as soon as practical.

### **Amplification**

Battery 1 discharge while Alt 1 is functioning normally, indicative of an internal power distribution failure within the MCU.

## Low Alternator 1 Output

### ***ALT 1 Caution (Failure)***



1. ALT 1 Circuit Breaker ..... CHECK & SET
2. ALT 1 Master Switch ..... CYCLE  
*If alternator does not reset (low A1 Current and M1 voltage):*
3. ALT 1 Master Switch ..... OFF
4. Non-Essential Bus Loads ..... REDUCE
  - a. If flight conditions permit, consider shedding the following to preserve Battery 1:
    - (1) Air Conditioning,
    - (2) Landing Light,
    - (3) Yaw Servo,
    - (4) Convenience Power (aux items plugged into armrest jack)
5. Continue Flight, avoiding IMC or night flight as able (reduced power redundancy).

### ***Amplification***

• **Caution** •

Dependant on Battery 1 state (indicated by M1 voltage), landing light may be weak or inoperative for landing.

Alternator 1 output is low, indicative of alternator failure; will typically be associated with low M1 voltage, Battery 1 discharge and M BUS 1 Caution message.

## Low Alternator 2 Output

### *ALT 2 Caution (Failure)*



1. ALT 2 Circuit Breaker ..... CHECK & SET
2. ALT 2 Master Switch ..... CYCLE  
*If alternator does not reset (low A2 Current and M2 voltage less than M1 voltage):*
3. ALT 2 Master Switch ..... OFF
4. Continue Flight, avoiding IMC or night flight as able (reduced power redundancy).

### **Amplification**

Alternator 2 output is low, indicative of alternator failure; isolated Alt 2 failure will not typically be associated with any other unusual indications, cautions or warnings (Alt 1 will pick up all loads).



# Integrated Avionics System

## Avionics Switch Off

### *AVIONICS OFF Caution*



1. AVIONICS Switch ..... ON, AS REQUIRED

### **Amplification**

The AVIONICS master switch is off.

## PFD Cooling Fan Failure

### *PFD FAN FAIL Advisory*



1. AVIONICS FAN 2 Circuit Breaker ..... CYCLE

*If annunciation does not extinguish:*

- a. Hot cabin temperatures ..... LAND AS SOON AS PRACTICAL
- b. Cool cabin temperatures ..... CONTINUE, MONITOR

### **Amplification**

The cooling fan for the PFD is inoperative.

## MFD Cooling Fan Failure

### *MFD FAN FAIL Advisory*



1. AVIONICS FAN 1 Circuit Breaker ..... CYCLE

*If annunciation does not extinguish:*

- a. High cabin temperatures .... LAND AS SOON AS PRACTICAL
- b. Low cabin temperatures ..... CONTINUE, MONITOR

### **Amplification**

The cooling fan for the MFD is inoperative.

## Flight Displays Too Dim

1. INSTRUMENT dimmer knob..... OFF (full counter-clockwise)  
*If flight displays do not provide sufficient brightness:*
2. Revert to standby instruments.

### **Amplification**

The instrument dimmer knob provides manual dimming control of the display screens, key and text backlighting, flap and Environmental Control System (ECS) status indicators, and standby instruments. Rotation of the dimmer knob fully counterclockwise disables the dimmer, and reverts to daytime lighting for all components. In the event of a dimmer control circuit failure, or to override the manual dimming circuit, pull the CABIN LIGHTS circuit breaker.

In daytime lighting (knob OFF/full counterclockwise, or with CABIN LIGHTS circuit breaker pulled):

- Electro-mechanical standby instruments, all avionics system keypad and the bolster switch panel are unlit
- MFD, PFD, and MD302 Standby Attitude Module (optional) screen illumination is controlled by automatic photocell (providing full brightness in high light conditions, only slightly reduced by darkness)
- ECS and control panels are backlit and their status lights are at maximum intensity

With active dimming (knob moved clockwise), the full bright position (full clockwise) applies maximum illumination to keys and switches, to standby instruments and to status lights, but the PFD, MFD, and MD302 Standby Attitude Module (optional) screen illumination is at a substantially reduced level (levels still appropriate for night flight). Maximum screen illumination (appropriate for daytime use) is with the dimmer OFF/full counterclockwise.

# Pitot Static System

## Pitot Static Malfunction

### **Static Source Blocked**

1. Pitot Heat .....ON
2. Alternate Static Source .....OPEN

### **Amplification**

If erroneous readings of the static source instruments (airspeed, altimeter and vertical speed) are suspected, the alternate static source valve, on side of console near pilot's right ankle, should be opened to supply static pressure from the cabin to these instruments. With the alternate static source on, adjust indicated airspeed slightly during climb or approach in accordance with Section 5, [Airspeed Calibration: Alternate Static Source](#) as appropriate for vent/ heater configuration.

### **Pitot Tube Blocked**

1. Pitot Heat .....ON

### **Amplification**

If only the airspeed indicator is providing erroneous information, and in icing conditions, the most probable cause is Pitot ice. If setting Pitot Heat ON does not correct the problem, descend to warmer air. If an approach must be made with a blocked Pitot tube, use known pitch and power settings and the GPS groundspeed indicator, taking surface winds into account.

## Pitot Heat Current Sensor Annunciation

### *PITOT HEAT FAIL Caution*

PITOT HEAT FAIL

1. Pitot Heat Circuit Breaker ..... CYCLE
2. Pitot Heat ..... CYCLE OFF, ON  
*If inadvertent icing encountered, perform [Inadvertent Icing Encounter Checklist](#) and:*
  - a. Airspeed ..... EXPECT NO RELIABLE INDICATION
  - b. Exit icing conditions using attitude, altitude, and power instruments.

#### ***Amplification***

Pitot heat failure. Displayed when Pitot heat switch is ON and Pitot heat current is not detected.

## Pitot Heat Required Annunciation

### *PITOT HEAT REQUIRED Caution*

PITOT HEAT REQD

1. Pitot Heat ..... ON

#### ***Amplification***

Displayed 20 seconds after system detects OAT is less than 41°F (5°C) and Pitot Heat Switch is OFF.

# Flight Control System

## Electric Trim/Autopilot Failure

1. Airplane Control ..... MAINTAIN MANUALLY
2. Autopilot (if engaged).....DISENGAGE  
*If Problem Is Not Corrected:*
3. Circuit Breakers ..... PULL AS REQUIRED
  - PITCH TRIM
  - ROLL TRIM
  - YAW SERVO
  - AP SERVOS
4. Power Lever ..... AS REQUIRED
5. Control Yoke ..... MANUALLY HOLD PRESSURE
6. Land as soon as practical.

### ***Amplification***

Any failure or malfunction of the electric trim or autopilot can be overridden by use of the control yoke. If runaway trim is the problem, de-energize the circuit by pulling the appropriate circuit breakers and land as soon as conditions permit.

## Flap System Exceedance

### ***FLAPS Caution***



1. Airspeed..... REDUCE  
*or*
1. Flaps ..... RETRACT

### ***Amplification***

Flaps are extended beyond airspeed limitations.

Flaps at 100%, airspeed greater than 115 KIAS for 5 seconds or more,  
OR

Flaps at 50%, airspeed greater than 155 KIAS for 5 seconds or more.

## Landing Gear System

### Brake Failure During Taxi

1. Engine Power..... AS REQUIRED
  - To stop airplane - REDUCE
  - If necessary for steering - INCREASE
2. Directional Control ..... MAINTAIN WITH RUDDER
3. Brake Pedal(s) ..... PUMP  
*If directional control can not be maintained:*
4. Ignition Switch..... OFF

#### **Amplification**

Ground steering is accomplished by differential braking. However, increasing power may allow some rudder control due to increased groundspeed and airflow over the rudder.

### Left/Right Brake Over-Temperature

#### **BRAKE TEMP Caution**

**BRAKE TEMP**

1. Stop aircraft and allow the brakes to cool.

#### **Amplification**

Brake temperature is between 270°F and 293°F for more than 5 seconds. Refer to Section 10, [Taxiing, Steering, and Braking Practices](#) for additional information.

# Oxygen System

## Oxygen Quantity Low

### ***OXYGEN QTY Caution***

OXYGEN QTY
------------

1. Oxygen Pressure and Flow Rate ..... CHECK
2. Oxygen Duration ..... CALCULATE
  - a. See Oxygen AFMS; calculate duration based on remaining pressure, number of occupants and type of device (mask or cannula).
3. Perform Normal *Descent* as necessary, dependant on duration calculation.

### ***Amplification***

1. Annunciation indicated tank pressure is between 800 and 400 PSI, see Oxygen AFMS to determine remaining duration.

### ***OXYGEN RQD Caution***

OXYGEN RQD
------------

1. Oxygen Masks or Cannulas ..... DON
2. Oxygen System ..... ON
3. Oxygen Flow Rate ..... ADJUST as necessary for cruise altitude

### ***Amplification***

Annunciation indicates that aircraft is above 10000 ft and system is not ON.

***OXYGEN QTY Advisory***

**OXYGEN QTY**

***On-Ground***

1. Oxygen Supply ..... REPLENISH if use of oxygen is anticipated

***In-Flight***

1. If use of oxygen is anticipated, verify adequate oxygen supply for flight duration. Refer to Duration chart in Oxygen System AFMS.

***Amplification***

Annunciation indicates oxygen tank pressure is below 800 PSI at pressure altitudes below 10,000 ft.

***OXYGEN SYSTEM LEFT ON Advisory***

**OXYGEN LEFT ON**

1. Oxygen System ..... OFF

***Amplification***

Annunciation indicates that after oxygen system has been left ON after on-ground engine shutdown. If system is left ON and aircraft power is turned OFF, the solenoid valve will remain open and may result in unexpected leakage and pressure loss.



## Other Conditions

### Aborted Takeoff

1. Power Lever..... IDLE
2. Brakes..... AS REQUIRED

#### ***Amplification***

Use as much of the remaining runway as needed to safely bring the airplane to a stop or to slow the airplane sufficiently to turn off runway.

#### **• Caution •**

For maximum brake effectiveness, retract flaps, hold control yoke full back, and bring the airplane to a stop by smooth, even application of the brakes.

After a high-speed aborted takeoff, brake temperatures will be elevated; subsequent aborted takeoffs or other high-energy use of the brakes may cause brake overheat, failure and possibly even fire. A 25-minute cooling time is recommended following high-energy use of the brake system before attempting to conduct operations that may require further high-energy braking. Brake temperature indicator should be inspected prior to flight following a high-energy brake event. Refer to Section 4, *Preflight Inspection* Checklist for additional detail.

## Parking Brake Engaged Annunciation

### *PARK BRAKE Caution*



1. Parking Brake ..... RELEASE
2. Monitor CAS for BRAKE TEMP Caution. Stop aircraft and allow the brakes to cool if necessary.

#### ***Amplification***

Parking brake is set.

## Communications Failure

1. Switches, Controls ..... CHECK
2. Frequency ..... CHANGE
3. Circuit Breakers ..... SET
4. Headset ..... CHANGE
5. Hand Held Microphone ..... CONNECT

#### ***Amplification***

If, after following the checklist procedure, communication is not restored, proceed with FAR/AIM lost communications procedures.

• Note •

In the event of an audio panel power failure the audio panel connects COM 1 to the pilot's headset and speakers. Setting the audio panel 'Off' will also connect COM 1 to the pilot's headsets and speakers.

# ***Section 4: Normal Procedures***

## **Table of Contents**

Introduction .....	3
Airspeeds for Normal Operation .....	3
Normal Procedures .....	4
Preflight Inspection .....	4
Before Starting Engine.....	9
Starting Engine .....	10
Before Taxiing.....	12
Taxiing .....	12
Before Takeoff .....	13
Maximum Power Fuel Flow .....	15
Normal Takeoff .....	16
Short Field Takeoff .....	16
Full Power Climb: Rich of Peak Technique .....	18
Cruise Climb: Lean of Peak Technique .....	20
Cruise .....	21
Descent.....	23
Before Landing .....	23
Normal Landing .....	24
Short Field Landing.....	25
Balked Landing/Go-Around .....	26
After Landing .....	26
Shutdown.....	27
Stalls .....	28
Environmental Considerations .....	29
Cold Weather Operation .....	29
Hot Weather Operation.....	31
Extended Ground Operation.....	31
Noise Characteristics/Abatement.....	32
Fuel Conservation .....	32

Intentionally Left Blank

## Introduction

This section provides amplified procedures for normal operation. Normal procedures associated with optional systems can be found in [Section 9: Log of Supplements](#).

## Airspeeds for Normal Operation

Unless otherwise noted, the following speeds are based on a maximum weight of 3600 lb. and may be used for any lesser weight. However, to achieve the performance specified in Section 5 for takeoff and landing distance, the speed appropriate to the particular weight must be used.

### Takeoff Rotation:

- Normal, Flaps 50% ..... 77 KIAS
- Obstacle Clearance, Flaps 50% ..... 85 KIAS

### Enroute Climb, Flaps Up:

- Best Rate of Climb, SL ..... 103 KIAS
- Best Rate of Climb, 10,000 ..... 102 KIAS
- Best Angle of Climb, SL ..... 88 KIAS
- Best Angle of Climb, 10,000 ..... 88 KIAS
- Normal, Full Power, Full Rich Climb ..... 120 KIAS

### Landing Approach:

- Normal Approach, Flaps Up ..... 90-95 KIAS
- Normal Approach, Flaps 50% ..... 85-90 KIAS
- Normal Approach, Flaps 100% ..... 80-85 KIAS
- Short Field, Flaps 100% ( $V_{REF}$ ) ..... 79 KIAS

### Go-Around, Flaps 50%:

- Full Power ..... 80 KIAS

### Maximum Recommended Turbulent Air Penetration:

- 3600 lb ..... 140 KIAS
- 2900 lb ..... 123 KIAS

### Maximum Demonstrated Crosswind Velocity:

- Takeoff or Landing ..... 21 Knots

# Normal Procedures

## Preflight Inspection

Before carrying out preflight inspections, ensure that all required maintenance has been accomplished. Review your flight plan and compute weight and balance. Throughout the walk-around: check all hinges, hinge pins, and bolts for security; check skin for damage, condition, and evidence of delamination; check all control surfaces for proper movement and excessive free play; check area around liquid reservoirs and lines for evidence of leaking.

In cold weather, remove all frost, ice, or snow from fuselage, wing, stabilizers and control surfaces. Ensure that control surfaces are free of internal ice or debris. Check that wheel fairings are free of snow and ice accumulation. Check that Pitot probe warms within 30 seconds of setting Pitot Heat to ON.

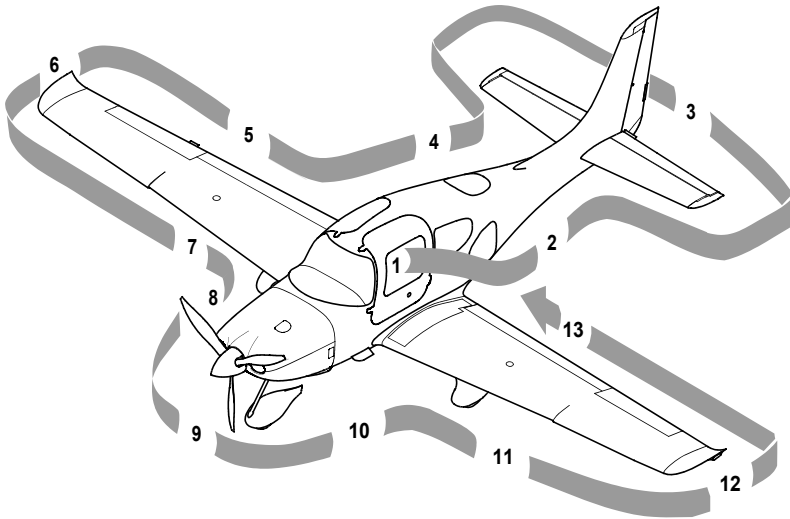

SR22\_FM04\_1454

1. Cabin
  - a. Required Documents ..... On Board
  - b. Avionics Power Switch ..... OFF

*(Continued on following page)*

- c. Bat 2 Master Switch ..... ON
- d. PFD ..... Verify On
- e. Essential Bus Voltage..... 23-25 Volts
- f. Flap Position Light ..... OUT
- g. Bat 1 Master Switch ..... ON
- h. Avionics Cooling Fan..... Audible
- i. Oxygen Masks/Cannulas and Hoses ..... Check Condition
- j. Oxygen System ..... ON
  - (1) Quantity..... Verify adequate supply for flight with reserve
  - (2) Flow ..... Check flowmeter on all masks
  - (3) Oxygen System..... OFF
- k. Lights..... Check Operation
- l. Stall Warning ..... Test

• Note •

Test stall warning system by applying suction to the stall warning system inlet and noting the warning horn sounds.

- m. Fuel Quantity ..... Check
  - n. Fuel Selector ..... Select Fullest Tank
  - o. Flaps..... 100%, Check Light ON
  - p. Bat 1 and 2 Master Switches..... OFF
  - q. Circuit Breakers..... IN
  - r. Fire Extinguisher ..... Charged and Available
  - s. Emergency Egress Hammer ..... Available
  - t. CAPS Handle ..... Pin Removed
2. Left Fuselage
- a. Door Lock ..... Unlock
  - b. COM 1 Antenna (top) ..... Condition and Attachment
  - c. Transponder Antenna (underside)... Condition and Attachment
  - d. Wing/Fuselage Fairing ..... Check
  - e. COM 2 Antenna (underside) ..... Condition and Attachment

*(Continued on following page)*

- f. Baggage Door ..... Closed and Secure
  - g. Static Button ..... Check for Blockage
  - h. Parachute Cover..... Sealed and Secure
3. Empennage
- a. Tiedown Rope..... Remove
  - b. Horizontal and Vertical Stabilizers .....Condition

• Note •

Verify tape covering the forward and aft inspection holes located on outboard ends of horizontal stabilizer is installed and securely attached.

- c. Elevator and Tab..... Condition and Movement
  - d. Rudder.....Freedom of Movement
  - e. Rudder Trim Tab .....Condition and Security
  - f. Attachment hinges, bolts and cotter pins..... Secure
4. Right Fuselage
- a. Static Button ..... Check for Blockage
  - b. Wing/Fuselage Fairings.....Check
  - c. Door Lock ..... Unlock
5. Right Wing Trailing Edge
- a. Flap and Rub Strips (if installed).....Condition and Security
  - b. Aileron and Tab..... Condition and Movement
  - c. Aileron Gap Seal ..... Security
  - d. Hinges, actuation arm, bolts, and cotter pins ..... Secure
6. Right Wing Tip
- a. Tip.....Attachment
  - b. Strobe, Nav Light and Lens .....Condition and Security
  - c. Fuel Vent (underside) ..... Unobstructed
7. Right Wing Forward and Main Gear
- a. Leading Edge and Stall Strips.....Condition
  - b. Fuel Cap ..... Check Quantity and Secure
  - c. Fuel Drains (2 underside)..... Drain and Sample

*(Continued on following page)*



- d. Wheel Fairings ..... Security, Accumulation of Debris
- e. Tire ..... Condition, Inflation, and Wear

**• Caution •**

*Serials 0442 thru 0656, 0658 thru 0689 before SB2X-32-21:*  
Clean and inspect temperature indicator installed to piston housing. If indicator center is black, the brake assembly has been overheated. The brake linings must be inspected and O-rings replaced.

- f. Wheel and Brakes ..... Fluid Leaks, Evidence of Overheating, General Condition, and Security.
  - g. Chocks and Tiedown Ropes.....Remove
8. Nose, Right Side
- a. Vortex Generator ..... Condition
  - b. Cowling.....Attachments Secure
  - c. Exhaust Pipe ..... Condition, Security, and Clearance
  - d. Gascolator (underside).....Drain for 3 seconds, Sample
9. Nose gear, Propeller, and Spinner

**• WARNING •**

Keep clear of propeller rotation plane. Do not allow others to approach propeller.

- a. Tow Bar ..... Remove and Stow
  - b. Strut..... Condition
  - c. Wheel Fairing ..... Security, Accumulation of Debris
  - d. Wheel and Tire ..... Condition, Inflation, and Wear
  - e. Propeller ..... Check adequate Ground Clearance
  - f. Spinner ..... Condition, Security, and Oil Leaks
  - g. Air Inlets ..... Unobstructed
  - h. Alternator..... Condition
10. Nose, Left Side
- a. Landing Light..... Condition
  - b. Engine Oil..... Check 6-8 quarts, Leaks, Cap & Door Secure

*(Continued on following page)*

- c. Cowling ..... Attachments Secure
- d. External Power ..... Door Secure
- e. Vortex Generator ..... Condition
- f. Exhaust Pipe(s) ..... Condition, Security, and Clearance

11. Left Main Gear and Forward Wing

- a. Wheel fairings ..... Security, Accumulation of Debris
- b. Tire ..... Condition, Inflation, and Wear

• **Caution** •

*Serials 0442 thru 0656, 0658 thru 0689 before SB2X-32-21:*  
Clean and inspect temperature indicator installed to piston housing. If indicator center is black, the brake assembly has been overheated. The brake linings must be inspected and O-rings replaced.

- c. Wheel and Brakes ..... Fluid Leaks, Evidence of Overheating, General Condition, and Security.
- d. Chocks and Tiedown Ropes ..... Remove
- e. Fuel Drains (2 underside) ..... Drain and Sample
- f. Fuel Cap ..... Check Quantity and Secure
- g. Leading Edge and Stall Strips ..... Condition

12. Left Wing Tip

- a. Fuel Vent (underside) ..... Unobstructed
- b. Pitot Mast (underside) ..... Cover Removed, Tube Clear
- c. Strobe, Nav Light and Lens ..... Condition and Security
- d. Tip ..... Attachment

13. Left Wing Trailing Edge

- a. Flap And Rub Strips (If installed) ..... Condition and Security
- b. Aileron ..... Freedom of movement
- c. Aileron Gap Seal ..... Security
- d. Hinges, actuation arm, bolts, and cotter pins ..... Secure

## Before Starting Engine

1. Preflight Inspection .....COMPLETED
2. Weight and Balance ..... Verify within limits
3. Emergency Equipment ..... ON BOARD
4. Passengers ..... BRIEFED
5. Seats, Seat Belts, and Harnesses .....ADJUST & SECURE

### ***Amplification***

#### **• WARNING •**

Ensure that the airplane is properly loaded and within the AFM's weight and balance limitations prior to takeoff.

#### **• Caution •**

Crew seats must be locked in position and control handles fully down before flight. Ensure seat belt harnesses are not twisted.

Prior to flight, Verify CAPS handle safety pin is removed and ensure all the passengers have been fully briefed on smoking, the use of the oxygen system, seat belts, doors, emergency exits, egress hammer, and CAPS.

## Starting Engine

1. External Power (If applicable) ..... CONNECT
2. Brakes ..... HOLD
3. Bat Master Switches ..... ON (Check Volts)
4. Strobe Lights ..... ON
5. Mixture ..... FULL RICH
6. Power Lever ..... FULL FORWARD
7. Fuel Pump ..... BOOST
8. Propeller Area ..... CLEAR
9. Power Lever ..... OPEN ¼ INCH
10. Ignition Switch ..... START (Release after engine starts)
11. Mixture ..... LEAN  
until RPM rises to a maximum value. Leave the mixture in this  
position during taxi and until run-up.
12. Power Lever ..... RETARD (to maintain 1000 RPM)
13. Oil Pressure ..... CHECK
14. Alt Master Switches ..... ON
15. Avionics Power Switch ..... ON
16. Engine Parameters ..... MONITOR
17. External Power (If applicable) ..... DISCONNECT
18. Amp Meter/Indication ..... CHECK

## ***Amplification***

### **• WARNING •**

If airplane will be started using external power, keep all personnel and power unit cables well clear of the propeller rotation plane.

### **• Caution •**

Alternators should be left OFF during engine starting to avoid high electrical loads.

During start, limit cranking to intervals of 10 seconds with a 20 second cooling period between cranks. This will improve battery and contactor life.

If the engine is warm priming is not required. On the first start of the day, especially under cool ambient conditions, holding the Fuel Pump switch to the HIGH BOOST/PRIME position for 2 seconds will improve starting.

Weak intermittent firing followed by puffs of black smoke from the exhaust stack indicates over-priming or flooding. Excess fuel can be cleared from the combustion chambers by the following procedure:

- Turn fuel pump off.
- Allow fuel to drain from intake tubes.
- Set the mixture control full lean and the power lever full open.
- Crank the engine through several revolutions with the starter.
- When engine starts, release ignition switch, retard power lever, and slowly advance the mixture control to FULL RICH position.

If the engine is under-primed, especially with a cold soaked engine, it will not fire, and additional priming will be necessary. As soon as the cylinders begin to fire, open the power lever slightly to keep it running. Refer to *Cold Weather Operation* in this section or additional information regarding cold weather operations.

After starting, if the oil gage does not begin to show pressure within 30 seconds in warm weather and about 60 seconds in very cold weather, shut down engine and investigate cause. Lack of oil pressure indicates loss of lubrication, which can cause severe engine damage.

## Before Taxiing

1. Flaps ..... UP (0%)
2. Radios/Avionics..... AS REQUIRED
3. Cabin Heat/Defrost ..... AS REQUIRED
4. Fuel Selector..... SWITCH TANK

## Taxiing

1. Parking Brake ..... DISENGAGE
2. Brakes..... CHECK
3. HSI Orientation..... CHECK
4. Attitude Gyro ..... CHECK
5. Turn Coordinator ..... CHECK

## Amplification

### • WARNING •

Maximum continuous engine speed for taxiing is 1000 RPM on flat, smooth, hard surfaces. Power settings slightly above 1000 RPM are permissible to start motion, for turf, soft surfaces, and on inclines. Use minimum power to maintain taxi speed.

If the 1000 RPM taxi power limit and proper braking procedures are not observed, the brake system may overheat and result in brake damage or brake fire.

When taxiing, directional control is accomplished with rudder deflection and intermittent braking (toe taps) as necessary. Use only as much power as is necessary to achieve forward movement. Deceleration or taxi speed control using brakes but without a reduction in power will result in increased brake temperature. Taxi over loose gravel at low engine speed to avoid damage to the propeller tips.

## Before Takeoff

1. Doors .....LATCHED
2. CAPS Handle..... Verify Pin Removed
3. Seat Belts and Shoulder Harness..... SECURE
4. Air Conditioner ..... AS DESIRED

**• Caution •**

Use of RECIRC mode prohibited in flight.

**• Note •**

If Air Conditioner is ON for takeoff roll, see Section 5, *Takeoff Distance* for takeoff distance change. No takeoff distance change is necessary if system remains OFF for takeoff roll.

5. Fuel Quantity ..... CONFIRM
6. Fuel Selector..... FULLEST TANK
7. Fuel Pump ..... BOOST
8. Mixture ..... FULL RICH
9. Flaps ..... SET 50% & CHECK
10. Transponder..... SET
11. Autopilot..... CHECK
12. Navigation Radios/GPS ..... SET for Takeoff
13. Cabin Heat/Defrost ..... AS REQUIRED
14. Brakes..... HOLD
15. Power Lever..... 1700 RPM
16. Alternator ..... CHECK
  - a. Pitot Heat..... ON
  - b. Navigation Lights ..... ON
  - c. Landing Light..... ON
  - d. Annunciator Lights..... CHECK  
Verify both ALT 1 and ALT 2 caution lights out and positive amps indication for each alternator.
17. Voltage..... CHECK
18. Pitot Heat..... AS REQUIRED

*(Continued on following page)*

- 19. Navigation Lights..... AS REQUIRED
- 20. Landing Light ..... AS REQUIRED
- 21. Magnetos ..... CHECK Left and Right  
RPM drop must not exceed 150 RPM for either magneto. RPM differential must not exceed 75 RPM between magnetos
  - a. Ignition Switch ..... R, note RPM, then BOTH
  - b. Ignition Switch ..... L, note RPM, then BOTH
- 22. Engine Parameters ..... CHECK
- 23. Power Lever ..... 1000 RPM
- 24. Flight Instruments, HSI, and Altimeter ..... CHECK & SET
- 25. Flight Controls ..... FREE & CORRECT
- 26. Trim ..... SET Takeoff
- 27. Autopilot ..... DISCONNECT

**Amplification**

**• WARNING •**

Do not takeoff with frost, ice, snow, or other contamination on the fuselage, wing, stabilizers, and control surfaces.

**• Caution •**

Because this aircraft has a turbocharged system that maintains 36.0 in.Hg manifold pressure for all takeoffs, the mixture should be full rich for takeoff, even at high elevation airports. Leaning for takeoff and during maximum performance climb may cause excessive cylinder head temperatures.

During cold weather operations, the engine should be properly warmed up before takeoff. In most cases this is accomplished when the oil temperature has reached at least 100°F (38°C). In warm or hot weather, precautions should be taken to avoid overheating during prolonged ground engine operation. Additionally, long periods of idling may cause fouled spark plugs.

Pitot Heat should be turned ON for flight into IMC, flight into visible moisture, or whenever ambient temperatures are 41° F (5° C) or less.

During the Magneto Check, if there is a doubt concerning operation of the ignition system, RPM checks at higher engine speeds will usually confirm whether a deficiency exists. An absence of RPM drop may



indicate faulty grounding of one side of the ignition system or magneto timing set in advance of the specified setting.

## Maximum Power Fuel Flow

For maximum power operations (Power Lever full forward - 2500 RPM, 36.0 in.Hg manifold pressure) fuel flow should be in the green arc.

For any power setting greater than 30.5 in.Hg (cruise power) fuel flow is indicated by a dynamically calculated green arc displayed on the fuel gage. Fuel flow should be maintained within this arc by use of the mixture lever.

## Normal Takeoff

1. Brakes ..... RELEASE (Steer with Rudder Only)
2. Power Lever ..... FULL FORWARD
3. Engine Parameters ..... CHECK
4. Elevator Control ..... ROTATE Smoothly at 77-80 KIAS
5. At 90 KIAS, Flaps ..... UP

## Short Field Takeoff

1. Flaps ..... 50%
2. Brakes ..... HOLD
3. Power Lever ..... FULL FORWARD
4. Engine Parameters ..... CHECK
5. Brakes ..... RELEASE (Steer with Rudder Only)
6. Elevator Control ..... ROTATE Smoothly at 77 KIAS
7. Airspeed at Obstacle ..... 85 KIAS

## ***Amplification***

The fuel pump should be in the BOOST position during takeoff and for climb as required for vapor suppression with hot or warm fuel.

### Takeoff Power Check

Check full-throttle engine operation early in takeoff run. The engine should run smoothly and turn approximately 2500 RPM. All engine parameters are not in caution or warning ranges. Discontinue takeoff at any sign of rough operation or sluggish acceleration. Make a thorough full-throttle static run-up before attempting another takeoff.

Manifold pressure may temporarily increase to 36.0 - 37.0 in.Hg on first flight of the day due to cooler oil temperatures and associated higher oil pressures. This is acceptable under these conditions but normal full throttle manifold pressure should be 36.0 in.Hg. The fuel flow will normally also increase in proportion to the increase in manifold pressure. If manifold pressure exceeds 37.0 in.Hg on takeoff or during full power climbs, reduce power to maintain no more than 37.0 in.Hg.

For takeoff over a gravel surface, advance Power Lever slowly. This allows the airplane to start rolling before high RPM is developed, and gravel will be blown behind the propeller rather than pulled into it.

### Takeoff Flap Settings

Normal and short field takeoffs are accomplished with flaps set at 50%. Takeoffs using 0% are permissible, however, no performance data is available for takeoffs in the flaps up configuration. Takeoffs with 100% flaps are not approved.

Soft or rough field takeoffs are performed with 50% flaps by lifting the airplane off the ground as soon as practical in a tail-low attitude. If no obstacles are ahead, the airplane should be leveled off immediately to accelerate to a higher climb speed.

Takeoffs into strong crosswinds are normally performed with the flaps set at 50% to minimize the drift angle immediately after takeoff. With the ailerons fully deflected into the wind, accelerate the airplane to a speed slightly higher than normal while decreasing the aileron deflection as speed increases then - with authority - rotate to prevent possibly settling back to the runway while drifting. When clear of the ground, make a coordinated turn into the wind to correct for drift.

## Full Power Climb: Rich of Peak Technique

1. Oxygen..... AS REQUIRED
2. Power Lever .....FULL FORWARD
3. Mixture .....Maintain Fuel Flow in GREEN ARC
4. Flaps ..... Verify UP
5. Airspeed..... 120 KIAS
6. Fuel Pump..... BOOST
7. Fuel Flow ..... MONITOR
8. Engine Parameters ..... MONITOR

### ***Amplification***

The fuel pump should be in the BOOST position during takeoff and for climb as required for vapor suppression with hot or warm fuel. For maximum rate of climb, use the best rate-of-climb speeds shown in the *Enroute Rate of Climb* Chart in Section 5.

If an obstruction dictates the use of a steep climb angle, the best angle-of-climb speed should be used. Climbs at speeds lower than the best rate-of-climb speed should be of short duration to avoid engine-cooling problems.

During full power, full rich climbs, fuel flow should be maintained in the green arc. **If full rich fuel flow drops below the green range, this will usually be corrected by use of BOOST (below 18,000 feet) or HIGH BOOST/PRIME (above 18,000 feet).** If cylinder head temperatures consistently exceed 420°F, use higher airspeeds for better cooling.

**To avoid excessive CHTs, verify fuel pump is in the BOOST position.** For increased engine life do not allow CHTs to continuously exceed 420°F. If any CHT consistently exceeds 420°F during the climb, lower the nose and increase airspeed as required to maintain the hottest CHT at or below 420°F whenever practical. Intermittent CHTs up to 420°F are not a concern. Maximum CHT value remains 460 °F.

### *Use of High Boost / Prime Fuel Pump Setting*

**Under some extreme environmental conditions, the use of the fuel pump in the HIGH BOOST/PRIME position may be required in flight above 18,000 feet to adequately suppress vapor formation. This condition is most likely to occur during climbs above 18,000 feet on hot days with warm or hot fuel in the tanks.** Above 18,000 feet, if there is a loss of fuel flow or vapor locking is suspected, turn the fuel pump to

HIGH BOOST /PRIME position and reset the mixture as required to maintain adequate stable fuel flow. Vapor lock is most often indicated by any or a combination of the following:

- Fluctuations in normal fuel flow possibly coupled with abnormal engine operation;
- Rising EGTs and TIT coupled with falling fuel flow
- Rising CHTs (late in the process)

## Cruise Climb: Lean of Peak Technique

1. Power Lever ..... REDUCE to 30.5 in.Hg
2. Mixture ..... LEAN to cyan target or less
3. Minimum Airspeed ..... 120 KIAS
4. Fuel Pump ..... BOOST
5. Oxygen ..... AS REQUIRED
  - a. Oxygen Masks/Cannulas ..... DON
  - b. Oxygen System ..... ON
  - c. Flow Rate ..... ADJUST for planned cruise altitude
  - d. Flowmeters and Quantity ..... MONITOR
6. Cylinder Head Temperatures ..... MONITOR

### **Amplification**

Cruise climb with the mixture lever set to a lean mixture setting (LOP) is acceptable provided CHTs remain under 420°F. This climb procedure may not be possible in hot weather, but in moderate temperature conditions, LOP cruise climbs provide extended range and better fuel economy. Depending on aircraft weight and OAT, LOP cruise climbs will result in 600 to 700 FPM rates of climb at 130-140 KIAS.

Target fuel flow is calculated to provide the approximate Lean of Peak / "Best Economy" fuel-to-air ratio. Dependant on OAT and airspeed, this setting may not guarantee cylinder head temperatures below 420°F. If any CHT's are greater than 420°F, lean the mixture to maintain cylinders below 420°F. If cylinder head temperatures consistently exceed 420°F, climbs should be made at full rich mixture as described in the Climb Checklist.

## Cruise

1. Oxygen ..... AS REQUIRED
2. Cruise Altitude ..... ESTABLISHED
3. Power Lever ..... REDUCE to 30.5 in.Hg or less
4. Fuel Pump ..... AS REQUIRED

• Note •

The Fuel Pump must be set to BOOST during maneuvering flight (i.e. flight training maneuvers, chandelles, stalls, etc.).

5. Mixture ..... ADJUST
6. Engine Parameters ..... MONITOR
7. Fuel Flow and Balance ..... MONITOR  
*If any CHT's exceed 420°F:*
8. Mixture ..... LEAN 0.5 GPH and MONITOR

### **Amplification**

Recommended cruise is at a Lean of Peak / "Best Economy" mixture setting. Cruise leaning, i.e. leaning below full rich fuel flow, is only approved with manifold pressure settings of 30.5 in.Hg or less. Once power is reduced below this level, the green arc expands and a cyan colored Target Fuel Flow que is displayed on the fuel flow gage. With higher manifold pressures, the fuel flow gage provides a narrow green arc which defines full rich fuel flow settings.

Target fuel flow is determined using a calculated engine air flow based on Engine Speed, Manifold Air Temperature and Manifold Air Pressure and indicates a fuel flow that will give the approximate air-to-fuel ratio for best economy operation. Alternatively, the mixture can be set by finding a fuel flow that provides peak TIT and then leaning until TIT is 50°-75°F less than its peak value.

Target Fuel Flow is advisory only. This indicator or the Peak leaning method will provide an initial lean point only. As this setting is dependant on ambient air temperatures, it may not ensure sufficient cylinder cooling. If any CHT's are greater than 420°F, lean the mixture to maintain cylinders below 420°F. As an approximation, a 0.5 GPH reduction in fuel flow will reduce CHT's by 15°F.

Running the engine at mixture levels leaner than the target will improve cooling, but provide lower cruise power because engine power scales in proportion to fuel flow when the engine is running at

lean of peak. Other than lower cruise power, the only undesirable affect of an overly lean-of-peak setting is engine misfire. **Cruise mixture should be rich enough to avoid lean misfire, but no richer than target indicator for cruise.**

• Note •

The fuel pump is used for vapor suppression during climb. **It is also recommended that the fuel pump be left in BOOST after leveling off for 30 minutes following a climb and anytime fuel flow or EGT anomalies occur.** Under some previously described extreme environmental conditions, the use of HIGH BOOST/PRIME may be required for vapor suppression during cruise flight. The fuel pump can be returned to the BOOST or OFF position as conditions permit.



## Descent

1. Oxygen ..... AS REQUIRED
2. Altimeter..... SET
3. Cabin Heat/Defrost ..... AS REQUIRED
4. Landing Light ..... ON
5. Fuel System ..... CHECK
6. Power Lever ..... AS REQUIRED

### *For Rapid Descent:*

- a. Power Lever ..... Smoothly REDUCE MAP 18 to 20 in.Hg
7. Mixture ..... AS REQUIRED

### *For Rapid Descent:*

- a. Mixture ..... Maintain CHTs above 240°F
8. Brake Pressure ..... CHECK

## Amplification

Avoid prolonged idle settings. Maintain a CHT of 240°F (116°C) or greater.

## Before Landing

1. Seat Belt and Shoulder Harness ..... SECURE
2. Fuel Pump ..... BOOST
3. Mixture ..... FULL RICH
4. Flaps ..... AS REQUIRED
5. Autopilot ..... AS REQUIRED

## Normal Landing

1. Flaps ..... 100%
2. Airspeed ..... 80-85 KIAS
3. Power Lever ..... AS REQUIRED

*After touchdown:*

4. Brakes ..... AS REQUIRED

### **Amplification**

#### **• Caution •**

Landings should be made with full flaps. Landings with less than full flaps are recommended only if the flaps fail to deploy or to extend the aircraft's glide distance due to engine malfunction. Landings with flaps at 50% or 0%; power should be used to achieve a normal glide path and low descent rate. Flare should be minimized.

Normal landings are made with full flaps with power on or off. Surface winds and air turbulence are usually the primary factors in determining the most comfortable approach speeds.

Actual touchdown should be made with power off and on the main wheels first to reduce the landing speed and subsequent need for braking. Gently lower the nose wheel to the runway after airplane speed has diminished. This is especially important for rough or soft field landings.

### *Crosswind Landings*

Normal crosswind landings are made with full flaps. Avoid prolonged slips. After touchdown, hold a straight course with rudder and brakes as required. The maximum allowable crosswind velocity is dependent upon pilot capability as well as aircraft limitations. Operation in direct crosswinds of 21 knots has been demonstrated.

## Short Field Landing

1. Flaps ..... 100%
2. Airspeed..... 79 KIAS
3. Power Lever..... AS REQUIRED  
*After clear of obstacles:*
4. Power Lever..... REDUCE TO IDLE  
*After touchdown:*
5. Brakes..... MAXIMUM

### **Amplification**

For a short field landing in smooth air conditions, make an approach at 79 KIAS with full flaps using enough power to control the glide path (slightly higher approach speeds should be used under turbulent air conditions).

After all approach obstacles are cleared, progressively reduce power to reach idle just before touchdown and maintain the approach speed by lowering the nose of the airplane.

Touchdown should be made power-off and on the main wheels first. Immediately after touchdown, lower the nose wheel and apply braking as required. For maximum brake effectiveness, retract the flaps, hold the control yoke full back, and apply maximum brake pressure without skidding.

## Balked Landing/Go-Around

1. Autopilot ..... DISENGAGE
2. Power Lever ..... FULL FORWARD
3. Flaps ..... 50%
4. Airspeed ..... 80-85 KIAS  
*After clear of obstacles:*
5. Flaps ..... UP

### **Amplification**

In a balked landing (go around) climb, disengage autopilot, apply full power, then reduce the flap setting to 50%. If obstacles must be cleared during the go around, climb at 80-85 KIAS with 50% flaps. After clearing any obstacles, retract the flaps and accelerate to the normal flaps up climb speed.

## After Landing

1. Power Lever ..... 1000 RPM
2. Fuel Pump ..... OFF or BOOST
3. Mixture ..... LEAN to obtain maximum idle RPM
4. Flaps ..... UP
5. Transponder ..... STBY
6. Lights ..... AS REQUIRED
7. Pitot Heat ..... OFF

• Note •

As the airplane slows the rudder becomes less effective and taxiing is accomplished using differential braking.

## Shutdown

1. Fuel Pump (if used) ..... OFF
2. Throttle..... IDLE
3. Ignition Switch..... CYCLE
4. Mixture .....CUTOFF
5. All Switches ..... OFF
6. Magnetos ..... OFF
7. ELT..... TRANSMIT LIGHT OUT
8. Chocks, Tie-downs, Pitot Covers..... AS REQUIRED

### ***Amplification***

**• Caution •**

Note that the engine hesitates as the switch cycles through the “OFF” position. If the engine does not hesitate, one or both magnetos are not grounded. Prominently mark the propeller as being “Hot,” and contact maintenance personnel immediately.

After a hard landing, the ELT may activate. If this is suspected, press the RESET button.

## Stalls

Aircraft stall characteristics are conventional. Power-off stalls may be accompanied by a slight nose bobbing if full aft stick is held. Power-on stalls are marked by a high sink rate at full aft stick. Power-off stall speeds at maximum weight for both forward and aft CG positions are presented in Section 5 - *Stall Speeds*.

When practicing stalls at altitude, as the airspeed is slowly reduced, you will notice a slight airframe buffet, hear the stall speed warning horn sound between 5 and 10 knots before the stall, and see the Crew Alerting System display a STALL Warning annunciation. Normally, the stall is marked by a gentle nose drop and the wings can easily be held level or in the bank with coordinated use of the ailerons and rudder. Upon stall warning in flight, recovery is accomplished by immediately reducing back pressure to maintain safe airspeed, adding power if necessary and rolling wings level with coordinated use of the controls.

### • WARNING •

Extreme care must be taken to avoid uncoordinated, accelerated or abused control inputs when close to the stall, especially when close to the ground.

## Environmental Considerations

### Cold Weather Operation

#### • Caution •

An engine that has been superficially warmed, may start and appear to run satisfactorily, but can be damaged from lack of lubrication due to the congealed oil blocking proper oil flow through the engine. The amount of damage will vary and may not become evident for many hours. However, the engine may be severely damaged and may fail shortly following application of high power. Proper procedures require thorough application of preheat to all parts of the engine. Hot air must be applied directly to the oil sump and external oil lines as well as the cylinders, air intake and oil cooler. Because excessively hot air can damage non-metallic components such as composite parts, seals, hoses, and drives belts, do not attempt to hasten the preheat process.

#### *Starting*

If the engine has been cold soaked, it is recommended that the propeller be pulled through by hand several times to break loose or limber the oil. This procedure will reduce power draw on the battery if a battery start is made.

When the engine has been exposed to temperatures at or below 20°F (-7°C) for a period of two hours or more, the use of an external preheater and external power is recommended. Failure to properly preheat a cold-soaked engine may result in oil congealing within the engine, oil hoses, and oil cooler with subsequent loss of oil flow, possible internal damage to the engine, and subsequent engine failure.

If the engine does not start during the first few attempts, or if engine firing diminishes in strength, the spark plugs have probably frosted over. Preheat must be used before another start is attempted.

#### • Note •

When the oil temperature has reached 100°F (38°C) and oil pressure does not exceed 70 psi at 2500 RPM, the engine has been warmed sufficiently to accept full rated power.

1. Ignition Switch..... OFF

**• WARNING •**

Use caution when pulling the propeller through by hand. Make sure ignition switch is OFF, keys are out of ignition, and then act as if the engine will start.

2. Propeller..... Hand TURN several rotations  
3. External Power (If applicable) ..... CONNECT  
4. Brakes ..... HOLD  
5. Bat Master Switches ..... ON (check voltage)  
6. Mixture ..... FULL RICH  
7. Power lever ..... FULL FORWARD  
8. Fuel Pump..... HIGH BOOST/PRIME, then BOOST

**• Note •**

In temperatures down to 20°F, hold Fuel Pump switch to HIGH BOOST/PRIME for 15 seconds prior to starting.

9. Propeller Area ..... CLEAR  
10. Power Lever ..... OPEN ¼ INCH  
11. Ignition Switch ..... START (Release after engine starts)

**• Caution •**

Limit cranking to intervals of 10 seconds with a 20 second cooling period between cranks.

12. Power Lever ..... RETARD (to maintain 1000 RPM)  
13. Oil Pressure ..... CHECK  
14. Alt Master Switches ..... ON  
15. Avionics Power Switch ..... ON  
16. Engine Parameters ..... MONITOR  
17. External Power (If applicable) ..... DISCONNECT  
18. Amp Meter/Indication ..... CHECK  
19. Strobe Lights ..... ON



## Hot Weather Operation

Avoid prolonged engine operation on the ground. Fuel BOOST must be ON for engine start and takeoff, and should be ON during climb for vapor suppression which could occur under hot ambient conditions or after extended idle.

### Ground Operation of Air Conditioning (If Installed)

• Note •

To facilitate faster cabin cooling, prior to engine start leave the cabin doors open for a short time to allow hot air to escape cabin.

1. Control Panel ..... SELECT Desired Mode and Temperature
2. Voltage ..... MONITOR

• Note •

Decrease electrical load if battery discharge is noted.

3. Annunciator Lights ..... CHECK
  - a. Verify ALT 1 caution light out and positive amps indication.
4. Engine Parameters ..... CHECK

## Extended Ground Operation

For airplanes that experience prolonged engine operation on the ground, the following procedure is recommended to reduce potential for spark plug lead fouling and lead build-up on engine valve guides.

1. Set throttle to 1200 RPM.
2. Lean the mixture for maximum RPM.
3. Reduce throttle to RPM for continued ground operations (800 - 1000 RPM is recommended).

• WARNING •

Before takeoff, the mixture lever must be returned to the full forward/rich position.

• Note •

If further ground operations will be required after the BEFORE TAKEOFF checklist is completed, lean the mixture again (as described above) until ready for the TAKEOFF checklist.

## Noise Characteristics/Abatement

The certificated noise levels for the aircraft established in accordance with FAR 36 Appendix G are:

Configuration	Actual	Maximum Allowable
Hartzell 3-blade Propeller PHC-J3Y1F-1N/N7605(B)	81.5 dB(A)	88.0 dB(A)
Hartzell 3-blade Propeller PHC-J3Y1F-1N/N7605C(B)	81.5 dB(A)	88.0 dB(A)

No determination has been made by the Federal Aviation Administration that the noise levels of this airplane are or should be acceptable or unacceptable for operation at, into, or out of, any airport. The above noise levels were established at 3600 pounds takeoff weight and 2500 RPM.

Recently, increased emphasis on improving environmental quality requires all pilots to minimize the effect of airplane noise on the public. The following suggested procedures minimize environmental noise when operating the aircraft.

• Note •

Do not follow these noise abatement procedures where they conflict with Air Traffic Control clearances or instructions, weather considerations, or wherever they would reduce safety.

1. When operating VFR over noise-sensitive areas, such as outdoor events, parks, and recreational areas, fly not less than 2000 feet above the surface even though flight at a lower level may be allowed.
2. For departure from or approach to an airport, avoid prolonged flight at low altitude near noise-sensitive areas.

## Fuel Conservation

Minimum fuel use at cruise will be achieved using Lean-of-Peak Cruise Climb.

# ***Section 5: Performance Data***

## **Table of Contents**

Introduction .....	3
Associated Conditions Affecting Performance.....	3
Demonstrated Operating Temperature .....	3
Airspeed Calibration: Normal Static Source .....	4
Airspeed Calibration: Alternate Static Source .....	5
Altitude Correction	
Normal Static Source: Primary Flight Display .....	6
Altitude Correction	
Normal Static Source: Standby Altimeter .....	7
Altitude Correction	
Alternate Static Source: Primary Flight Display .....	8
Altitude Correction	
Alternate Static Source: Standby Altimeter .....	9
Temperature Conversion .....	10
Outside Air Temperature for ISA Condition .....	11
Stall Speeds .....	12
Wind Components .....	13
Takeoff Distance .....	14
Takeoff Distance: 3600 LB .....	15
Takeoff Distance: 2900 LB .....	16
Takeoff Climb Gradient .....	17
Takeoff Rate of Climb .....	18
Enroute Climb Gradient .....	19
Enroute Rate of Climb .....	20
Time, Fuel & Distance to Climb: Full Power Climb .....	21
Time, Fuel & Distance to Climb: Cruise Climb .....	22
Cruise Performance .....	23
Range / Endurance: Full Power Climb .....	26
Range / Endurance: Cruise Climb .....	29
Balked Landing Climb Gradient .....	32
Balked Landing Rate of Climb .....	33
Landing Distance .....	34
Landing Distance - Flaps 100% .....	35
Landing Distance - Flaps 50% .....	36
Landing Distance - Flaps 0% .....	37

Intentionally Left Blank

## Introduction

Performance data in this section are presented for operational planning so that you will know what performance to expect from the airplane under various ambient and field conditions. Performance data are presented for takeoff, climb, and cruise (including range & endurance).

*Aircraft with optional Air Conditioning System:* Brake Horsepower is reduced by approximately 6 BHP.

## Associated Conditions Affecting Performance

Computed performance data in this section are based upon data derived from actual flight testing with the airplane and engine in good condition and using average piloting techniques. Unless specifically noted in the “Conditions” notes presented with each table, ambient conditions are for a standard day (refer to Section 1, [Meteorological Terminology](#)). Flap position as well as power setting technique is similarly noted with each table.

The charts in this section provide data over temperature ranges as specified on the chart. If ambient temperature is below the chart value, use the lowest temperature shown to compute performance. This will result in more conservative performance calculations. If ambient temperature is above the chart value, use caution as performance degrades rapidly at higher temperatures.

## Demonstrated Operating Temperature

Satisfactory engine cooling has been demonstrated for this airplane with an outside air temperature 23°C above standard. The value given is not considered an operating limitation. Reference should be made to Section 2, [Powerplant Limitations](#) for operating limitations.

## Airspeed Calibration: Normal Static Source

**Conditions:**

- Power for level flight or maximum continuous, whichever is less.

• Note •

Indicated airspeed values assume zero instrument error.

KIAS	KCAS		
	Flaps 0%	Flaps 50%	Flaps 100%
60	57	50	56
70	68	66	69
80	79	80	80
90	89	92	91
100	100	102	102
110	111	113	113
120	121	121	
130	132	133	
140	142	144	
150	152	154	
160	163		
170	173		
180	183		
190	193		
200	203		
210	213		

# Airspeed Calibration: Alternate Static Source

**Conditions:**

- Power for level flight or maximum continuous, whichever is less.
- Heater, Defroster & Vents ..... ON

• Note •

Indicated airspeed values assume zero instrument error.

KIAS	KCAS		
	Flaps 0%	Flaps 50%	Flaps 100%
60	57	60	60
70	67	70	70
80	78	79	79
90	88	89	89
100	98	99	98
110	107	109	108
120	117	118	
130	127	128	
140	137	138	
150	146	148	
160	156		
170	166		
180	175		
190	185		
200	194		
210	204		

# Altitude Correction

## Normal Static Source: Primary Flight Display

**Conditions:**

- Power for level flight or maximum continuous, whichever is less.
- 3600 LB

• Note •

Add correction to desired altitude to obtain indicated altitude to fly.

Indicated airspeed values assume zero instrument error.

KIAS: Knots Indicated Airspeed.

Flaps	Density Alt	CORRECTION TO BE ADDED - FEET										
		Normal Static Source - KIAS										
		60	70	80	90	100	120	140	160	180	200	
0%	S.L		0	0	0	0	0	0	0	0	0	0
	5000		0	0	0	0	0	0	0	0	0	0
	10000		0	0	0	0	0	0	0	0	0	0
	15000		0	0	0	0	0	0	0	0	0	0
	20000		0	0	0	0	0	0	0	0	0	0
	25000		0	0	0	0	0	0	0	0	0	0
50%	S.L		9	-9	-19	-22	-19	-22	-28			
	5000		10	-10	-22	-25	-22	-25	-33			
	10000		12	-12	-25	-29	-25	-30	-38			
100%	S.L	22	-6	-10	-14	-19	-18					
	5000	25	-7	-12	-16	-22	-21					
	10000	29	-9	-14	-18	-25	-25					



# Altitude Correction

## Normal Static Source: Standby Altimeter

**Conditions:**

- Power for level flight or maximum continuous, whichever is less.
- 3600 LB

• Note •

Add correction to desired altitude to obtain indicated altitude to fly.

Indicated airspeed values assume zero instrument error.

KIAS: Knots Indicated Airspeed.

Flaps	Density Alt	CORRECTION TO BE ADDED - FEET									
		Normal Static Source - KIAS									
		60	70	80	90	100	120	140	160	180	200
0%	S.L		12	9	5	0	-11	-24	-38	-50	-61
	5000		14	10	6	0	-13	-28	-44	-58	-71
	10000		16	12	7	0	-16	-33	-51	-68	-82
	15000		19	14	8	0	-18	-39	-60	-80	-97
	20000		23	17	9	0	-21	-46	-71	-95	-114
	25000		27	20	11	0	-26	-55	-85	-112	-136
50%	S.L		21	0	-14	-21	-30	-46	-66		
	5000		24	0	-16	-25	-35	-54	-77		
	10000		28	0	-18	-29	-41	-63	-90		
100%	S.L	22	6	-1	-9	-19	-30				
	5000	25	7	-1	-10	-22	-34				
	10000	29	8	-2	-12	-25	-40				

# Altitude Correction

## Alternate Static Source: Primary Flight Display

**Conditions:**

- Power for level flight or maximum continuous, whichever is less.
- Heater, Defroster, & Vents .....ON

• Note •

Add correction to desired altitude to obtain indicated altitude to fly.

Indicated airspeed values assume zero instrument error.

KIAS: Knots Indicated Airspeed.

Flaps	Density Alt	CORRECTION TO BE ADDED - FEET									
		Alternate Static Source - KIAS									
		60	70	80	90	100	120	140	160	180	200
0%	S.L		4	8	14	21	40	64	94	127	164
	5000		4	10	16	25	47	75	109	148	191
	10000		5	11	19	29	55	87	127	172	222
	15000		6	13	23	34	64	102	149	202	261
	20000		7	15	27	40	76	121	176	239	308
	25000		8	18	32	48	90	144	209	284	366
50%	S.L		-10	-4	4	11	29	50	80		
	5000		-12	-4	4	13	33	58	93		
	10000		-14	-5	5	15	39	68	108		
100%	S.L	-2	-9	-2	6	15	39				
	5000	-2	-11	-2	7	17	45				
	10000	-3	-13	-3	8	20	53				

# Altitude Correction

## Alternate Static Source: Standby Altimeter

**Conditions:**

- Power for level flight or maximum continuous, whichever is less.
- Heater, Defroster, & Vents..... ON

• Note •

Add correction to desired altitude to obtain indicated altitude to fly.

Indicated airspeed values assume zero instrument error.

KIAS: Knots Indicated Airspeed.

Flaps	Density Alt	CORRECTION TO BE ADDED - FEET									
		Alternate Static Source - KIAS									
		60	70	80	90	100	120	140	160	180	200
0%	S.L		16	17	19	22	29	40	56	77	103
	5000		18	20	22	25	33	46	65	89	120
	10000		21	23	26	29	39	54	75	104	140
	15000		25	27	30	34	46	63	89	122	164
	20000		29	32	36	41	54	75	105	144	194
	25000		35	38	43	48	64	89	124	171	231
50%	S.L		2	5	9	11	17	25	42		
	5000		2	6	10	13	20	30	49		
	10000		3	7	12	16	23	34	57		
100%	S.L	-2	3	7	11	15	27				
	5000	-2	3	8	12	18	32				
	10000	-3	4	9	15	20	37				

# Temperature Conversion

To convert from Celsius (°C) to Fahrenheit (°F) find in the shaded columns the number representing the temperature value (°C) to be converted. The equivalent Fahrenheit temperature is read to the right.

► EXAMPLE: 38°C = 100°F.

To convert from Fahrenheit (°F) to Celsius (°C) find in the shaded columns the number representing the temperature value (°F) to be converted. The equivalent Celsius temperature is read to the left.

► EXAMPLE: 38°F = 3°C.

Temp to Convert °C or °F			Temp to Convert °C or °F			Temp to Convert °C or °F		
°C	◀ ▶	°F	°C	◀ ▶	°F	°C	◀ ▶	°F
-50	<b>-58</b>	-72	-17	<b>2</b>	36	17	<b>62</b>	144
-49	<b>-56</b>	-69	-16	<b>4</b>	39	18	<b>64</b>	147
-48	<b>-54</b>	-65	-14	<b>6</b>	43	19	<b>66</b>	151
-47	<b>-52</b>	-62	-13	<b>8</b>	46	20	<b>68</b>	154
-46	<b>-50</b>	-58	-12	<b>10</b>	50	21	<b>70</b>	158
-44	<b>-48</b>	-54	-11	<b>12</b>	54	22	<b>72</b>	162
-43	<b>-46</b>	-51	-10	<b>14</b>	57	23	<b>74</b>	165
-42	<b>-44</b>	-47	-9	<b>16</b>	61	24	<b>76</b>	169
-41	<b>-42</b>	-44	-8	<b>18</b>	64	26	<b>78</b>	172
-40	<b>-40</b>	-40	-7	<b>20</b>	68	27	<b>80</b>	176
-39	<b>-38</b>	-36	-6	<b>22</b>	72	28	<b>82</b>	180
-38	<b>-36</b>	-33	-4	<b>24</b>	75	29	<b>84</b>	183
-37	<b>-34</b>	-29	-3	<b>26</b>	79	30	<b>86</b>	187
-36	<b>-32</b>	-26	-2	<b>28</b>	82	31	<b>88</b>	190
-34	<b>-30</b>	-22	-1	<b>30</b>	86	32	<b>90</b>	194
-33	<b>-28</b>	-18	0	<b>32</b>	90	33	<b>92</b>	198
-32	<b>-26</b>	-15	1	<b>34</b>	93	34	<b>94</b>	201
-31	<b>-24</b>	-11	2	<b>36</b>	97	36	<b>96</b>	205
-30	<b>-22</b>	-8	3	<b>38</b>	100	37	<b>98</b>	208
-29	<b>-20</b>	-4	4	<b>40</b>	104	38	<b>100</b>	212
-28	<b>-18</b>	0	6	<b>42</b>	108	39	<b>102</b>	216
-27	<b>-16</b>	3	7	<b>44</b>	111	40	<b>104</b>	219
-26	<b>-14</b>	7	8	<b>46</b>	115	41	<b>106</b>	223
-24	<b>-12</b>	10	9	<b>48</b>	118	42	<b>108</b>	226
-23	<b>-10</b>	14	10	<b>50</b>	122	43	<b>110</b>	230
-22	<b>-8</b>	18	11	<b>52</b>	126	44	<b>112</b>	234
-21	<b>-6</b>	21	12	<b>54</b>	129	46	<b>114</b>	237
-20	<b>-4</b>	25	13	<b>56</b>	133	47	<b>116</b>	241
-19	<b>-2</b>	28	14	<b>58</b>	136	48	<b>118</b>	244
-18	<b>0</b>	32	16	<b>60</b>	140	49	<b>120</b>	248

## Outside Air Temperature for ISA Condition

Press Alt Feet	ISA-30°C		ISA-15°C		ISA		ISA+15°C		ISA+30°C	
	°C	°F	°C	°F	°C	°F	°C	°F	°C	°F
SL	-15	5	0	32	15	59	30	86	45	113
1000	-17	1	-2	28	13	55	28	82	43	109
2000	-19	-2	-4	25	11	52	26	79	41	106
3000	-21	-6	-6	21	9	48	24	75	39	102
4000	-23	-9	-8	18	7	45	22	72	37	99
5000	-25	-13	-10	14	5	41	20	68	35	95
6000	-27	-17	-12	10	3	37	18	64	33	91
7000	-29	-20	-14	7	1	34	16	61	31	88
8000	-31	-24	-16	3	-1	30	14	57	29	84
9000	-33	-27	-18	0	-3	27	12	54	27	81
10000	-35	-31	-20	-4	-5	23	10	50	25	77
11000	-37	-35	-22	-8	-7	19	8	46	23	73
12000	-39	-38	-24	-11	-9	16	6	43	21	70
13000	-41	-42	-26	-15	-11	12	4	39	19	66
14000	-43	-45	-28	-18	-13	9	2	36	17	63
15000	-45	-49	-30	-22	-15	5	0	32	15	59
16000	-47	-53	-32	-26	-17	1	-2	28	13	55
17000	-49	-56	-34	-29	-19	-2	-4	25	11	52
18000	-51	-60	-36	-33	-21	-6	-6	21	9	48
19000	-53	-63	-38	-36	-23	-9	-8	18	7	45
20000	-55	-67	-40	-40	-25	-13	-10	14	5	41
21000	-57	-71	-42	-44	-27	-17	-12	10	3	37
22000	-59	-74	-44	-47	-29	-20	-14	7	1	34
23000	-61	-78	-46	-51	-31	-24	-16	3	-1	30
24000	-63	-81	-48	-54	-33	-27	-18	0	-3	27
25000	-65	-85	-50	-58	-35	-31	-20	-4	-5	23

# Stall Speeds

**Conditions:**

- Weight ..... 3600 LB
- CG ..... Noted
- Power ..... Idle
- Bank Angle ..... Noted

• Note •

Altitude loss during wings level stall may be 250 feet or more.

KIAS values may not be accurate at stall.

Weight	Bank Angle	STALL SPEEDS					
		Flaps 0% Full Up		Flaps 50%		Flaps 100% Full Down	
		KIAS	KCAS	KIAS	KCAS	KIAS	KCAS
LB	Deg						
3600 Most FWD CG	0	74	73	70	67	64	61
	15	76	74	71	68	64	62
	30	80	78	74	72	67	65
	45	87	87	79	79	73	72
	60	103	103	92	94	85	86
3600 Most AFT CG	0	72	70	69	66	63	60
	15	73	71	70	67	64	61
	30	77	75	73	71	66	65
	45	84	83	79	78	72	72
	60	99	99	91	93	85	85

# Wind Components

**Example:**

- Runway Heading ..... 10°
- Wind Direction ..... 60°
- Wind Velocity ..... 15 Knots

• Note •

The max demonstrated crosswind is 21 knots. Value not considered limiting.

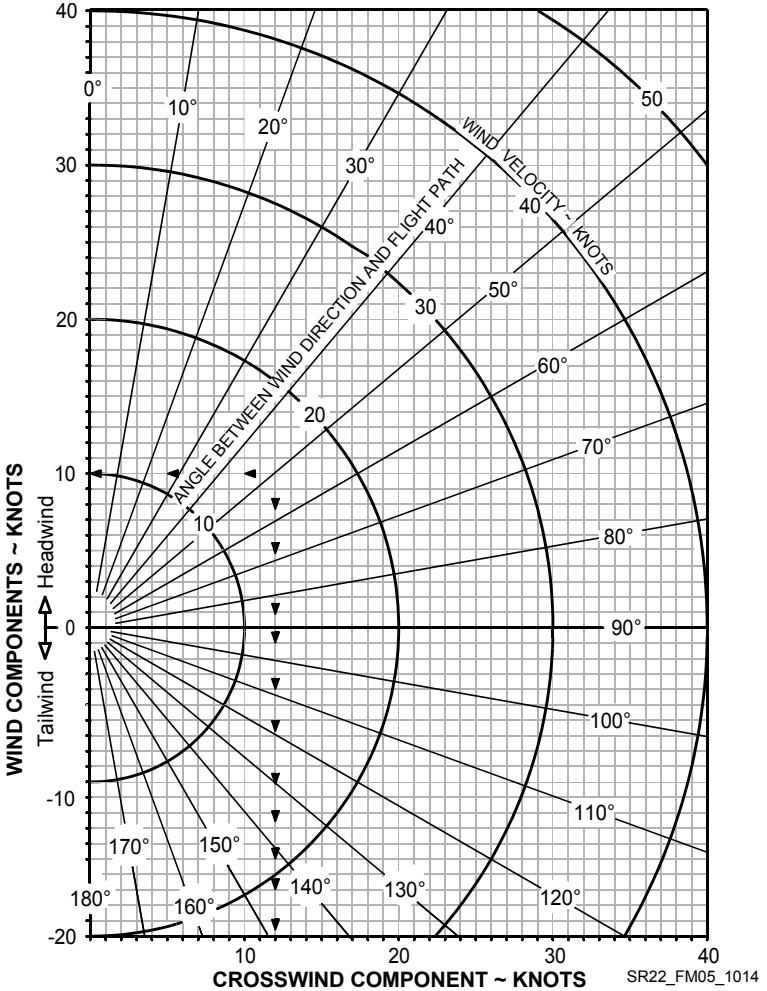

# Takeoff Distance

**Conditions:**

- Winds..... Zero
  - Runway..... Dry, Level, Paved
  - Flaps..... 50%
  - Air Conditioner..... OFF
  - Power:
  - Throttle ..... Full Open
  - Mixture..... Set per Placard
- Set prior to brake release for short field takeoff.

The following factors are to be applied to the computed takeoff distance for the noted condition:

Headwind - Subtract 10% from computed distance for each 12 knots headwind.

Tailwind - Add 10% for each 2 knots tailwind up to 10 knots.

Dry Grass Runway - Increase distances by 15% of the ground roll distance.

Sloped Runways - Increase distances by 22% of the ground roll value at Sea Level, 30% of the ground roll value at 5000 ft, 43% of the ground roll value at 10000 ft for each 1% of upslope; decrease distances by 7% of the ground roll value at Sea Level, 10% of the ground roll value at 5000 ft, and 14% of the ground roll value at 10000 ft for each 1% of downslope.

**• Caution •**

The above corrections for runway slope are required to be included herein under FAR 23. They should be used with caution since published runway slope data is usually the net slope from one end of the runway to the other. Many runways will have portions of their length at greater or lesser slopes than the published slope, lengthening (or shortening) takeoff ground run values estimated from the published slope as described above.

If brakes are not held while applying power, distances apply from the point where full throttle and mixture setting is complete.

For operation in outside air temperatures colder than the Takeoff Distance table provides, use the coldest data shown.

For operation in outside air temperatures warmer than the Takeoff Distance table provides, use caution.

Aircraft with optional Air Conditioning System: Add 100 feet to ground roll distance and 150 feet to distance over 50' obstacle if Air Conditioner is ON during takeoff.



# Takeoff Distance: 3600 LB

**Weight: 3600 LB**  
**Approx. Speed at Liftoff:** 80 KIAS  
**Speed over 50 Ft. Obstacle:** 85 KIAS  
**Flaps:** 50%  
**Power:** Full Throttle, Mixture Set  
**Runway:** Dry, Paved, Level

**Headwind:** Subtract 10% for each 12 knots headwind.  
**Tailwind:** Add 10% for each 2 knots tailwind up to 10 knots.  
**Dry Grass:** Add 15% of ground roll to distances.  
**Runway Slope:** Reference Caution.  
**Air Conditioner:** Add 100' to ground roll and 150' to distance over 50' obstacle if Air Conditioner if ON during takeoff.

PRESS ALT FT	DISTANCE FT	TEMPERATURE ~°C						ISA
		0	10	20	30	40	50	
SL	Grnd Roll	1352	1461	1574	1692	1814	1941	1517
	Total	1865	2007	2154	2307	2465	2629	2080
1000	Grnd Roll	1443	1559	1680	1805	1936	2071	1595
	Total	1980	2131	2288	2450	2618	2792	2178
2000	Grnd Roll	1540	1664	1793	1927	2066	2210	1677
	Total	2104	2264	2431	2603	2782	2967	2281
3000	Grnd Roll	1645	1777	1914	2058	2206	2361	1764
	Total	2236	2407	2584	2767	2958	3154	2390
4000	Grnd Roll	1757	1898	2045	2198	2357	2522	1856
	Total	2378	2559	2748	2943	3146	3355	2505
5000	Grnd Roll	1878	2029	2186	2350	2520	2696	1954
	Total	2530	2723	2924	3132	3347	3570	2627
6000	Grnd Roll	2008	2170	2338	2513	2694	2883	2058
	Total	2693	2899	3113	3334	3564	3802	2756
7000	Grnd Roll	2149	2322	2501	2688	2883	3084	2168
	Total	2868	3088	3315	3552	3796	4050	2892
8000	Grnd Roll	2300	2485	2678	2878	3086	3302	2284
	Total	3056	3290	3533	3785	4046	4316	3036
9000	Grnd Roll	2463	2661	2868	3082	3305	3536	2408
	Total	3258	3508	3767	4036	4314	4603	3188
10000	Grnd Roll	2640	2852	3073	3303	3541	3789	2540
	Total	3476	3742	4019	4306	4603	4911	3350

# Takeoff Distance: 2900 LB

<p><b>Weight: 2900 LB</b>  <b>Approx. Speed at Liftoff:</b> 67 KIAS  <b>Speed over 50 Ft. Obstacle:</b> 72 KIAS  <b>Flaps:</b> 50%  <b>Power:</b> Full Throttle, Mixture Set  <b>Runway:</b> Dry, Paved, Level</p>	<p><b>Headwind:</b> Subtract 10% for each 12 knots headwind.  <b>Tailwind:</b> Add 10% for each 2 knots tailwind up to 10 knots.  <b>Dry Grass:</b> Add 15% of ground roll to distances.  <b>Runway Slope:</b> Reference Caution.  <b>Air Conditioner:</b> Add 100' to ground roll and 150' to distance over 50' obstacle if Air Conditioner if ON during takeoff.</p>
--	--

PRESS ALT FT	DISTANCE FT	TEMPERATURE ~°C						
		0	10	20	30	40	50	ISA
<b>SL</b>	<b>Grnd Roll</b>	485	524	564	606	650	695	544
	<b>Total</b>	766	823	882	944	1007	1073	852
<b>1000</b>	<b>Grnd Roll</b>	517	559	602	647	694	742	571
	<b>Total</b>	812	872	935	1000	1068	1138	891
<b>2000</b>	<b>Grnd Roll</b>	552	596	642	690	740	792	601
	<b>Total</b>	861	925	992	1061	1133	1207	932
<b>3000</b>	<b>Grnd Roll</b>	589	637	686	737	791	846	632
	<b>Total</b>	914	982	1053	1126	1202	1281	975
<b>4000</b>	<b>Grnd Roll</b>	630	680	733	788	845	904	665
	<b>Total</b>	970	1043	1118	1196	1277	1360	1021
<b>5000</b>	<b>Grnd Roll</b>	673	727	783	842	903	966	700
	<b>Total</b>	1030	1108	1188	1271	1357	1446	1069
<b>6000</b>	<b>Grnd Roll</b>	720	778	838	900	965	1033	737
	<b>Total</b>	1095	1177	1262	1351	1442	1537	1120
<b>7000</b>	<b>Grnd Roll</b>	770	832	896	963	1033	1105	777
	<b>Total</b>	1164	1252	1343	1437	1534	1634	1174
<b>8000</b>	<b>Grnd Roll</b>	824	890	959	1031	1106	1183	819
	<b>Total</b>	1239	1332	1428	1529	1632	1739	1231
<b>9000</b>	<b>Grnd Roll</b>	883	954	1028	1104	1184	1267	863
	<b>Total</b>	1318	1418	1521	1627	1738	1852	1291
<b>10000</b>	<b>Grnd Roll</b>	946	1022	1101	1183	1269	1358	910
	<b>Total</b>	1404	1510	1620	1733	1851	1973	1354

# Takeoff Climb Gradient

**Conditions:**

- Power ..... Full Throttle
- Mixture ..... Full Rich
- Flaps ..... 50%
- Airspeed ..... Best Rate of Climb

• Note •

Climb Gradient values shown are the gain in altitude for the horizontal distance traversed expressed as Feet per Nautical Mile.

For operation in air colder than this table provides, use the coldest (left-most) data shown.

For operation in air warmer than this table provides, use caution.

Weight LB	Press Altitude FT	Climb Speed KIAS	CLIMB GRADIENT ~ Feet per Nautical Mile					
			Temperature ~°C					ISA
			-20	0	20	40	50	
3600	SL	91	1020	879	752	634	579	782
	2000	91	958	823	701	589	537	755
	4000	91	898	770	654	547	496	728
	6000	91	841	719	608	506	458	702
	8000	91	787	671	565	468	422	676
	10000	91	735	625	524	431	387	651
2900	SL	94	1303	1148	1002	864	797	1038
	2000	94	1251	1097	952	815	750	1016
	4000	93	1196	1043	900	765	701	991
	6000	93	1137	986	845	713	650	964
	8000	92	1077	928	790	660	599	935
	10000	92	1015	869	733	607	546	904

# Takeoff Rate of Climb

**Conditions:**

- Power ..... Full Throttle
- Mixture..... Full Rich
- Flaps..... 50%
- Airspeed ..... Best Rate of Climb

• Note •

Rate-of-Climb values shown are change in altitude in ft per unit time expressed in Feet per Minute

For operation in air colder than this table provides, use the coldest (left-most) data shown.

For operation in air warmer than this table provides, use caution.

Aircraft with optional Air Conditioning System: Maximum rate of climb performance is reduced by approximately 50 feet per minute if system is ON.

For maximum climb performance the air-conditioner should be off.

Weight LB	Press Altitude FT	Climb Speed KIAS	RATE OF CLIMB ~ Feet per Minute					
			Temperature ~°C					ISA
			-20	0	20	40	50	
3600	SL	91	1462	1314	1166	1019	946	1203
	2000	91	1425	1277	1130	983	910	1196
	4000	91	1388	1240	1093	947	874	1189
	6000	91	1352	1204	1057	910	837	1182
	8000	91	1315	1167	1020	874	801	1175
	10000	91	1278	1131	984	838	765	1168
2900	SL	94	1880	1730	1570	1404	1318	1611
	2000	94	1867	1709	1542	1370	1282	1618
	4000	93	1847	1681	1508	1329	1238	1621
	6000	93	1819	1646	1466	1282	1189	1619
	8000	92	1784	1604	1418	1228	1132	1613
	10000	92	1742	1555	1364	1169	1070	1602

# Enroute Climb Gradient

**Conditions:**

- Power ..... Full Throttle
- Mixture ..... Maintain Fuel Flow in GREEN ARC
- Flaps ..... 0% (UP)
- Airspeed ..... 120 KIAS

• Note •

Climb Gradient values shown are the gain in altitude for the horizontal distance traversed expressed as Feet per Nautical Mile.

For operation in air colder than this table provides, use the coldest (left-most) data shown.

For operation in air warmer than this table provides, use caution.

Weight LB	Press Altitude FT	Climb Speed KIAS	CLIMB GRADIENT - Feet per Nautical Mile						
			Temperature ~°C						
			-40	-20	0	20	40	50	ISA
3600	S.L.	120	931	798	679	571	473	427	597
	2000	120	866	740	627	524	430	386	569
	4000	120	804	685	577	480	390	349	542
	6000	120	746	632	530	438	353	313	516
	8000	120	690	583	486	398	317	279	490
	10000	120	638	536	444	360	284	248	466
	12000	120	588	491	404	325	252	218	442
	14000	120	541	449	367	292	222	190	419
	16000	120	497	410	332	260	195	164	397
	18000	120	455	373	299	231	169	139	376
	20000	120	415	337	267	203	144	117	356
	22000	120	390	245	119	9			306
24000	120	280	147	32				230	
25000	120	229	102					194	
2900	S.L.	120	1173	998	856	736	629	579	765
	2000	120	1083	932	806	695	594	546	744
	4000	120	1012	878	763	657	559	511	725
	6000	120	953	831	722	619	521	472	706
	8000	120	903	787	680	578	478	428	685
	10000	120	856	743	636	531	428	377	662
	12000	120	808	695	585	478	371	318	634
	14000	120	757	642	528	416	305	250	601
	16000	120	701	581	463	346	230	173	562
	18000	120	637	512	388	266	146	86	517
	20000	120	564	433	303	176	51		465
	22000	120	482	344	209	77			405
24000	120	389	245	105				337	
25000	120	339	192	49				300	

# Enroute Rate of Climb

**Conditions:**

- Power ..... Full Throttle
- Mixture ..... Maintain Fuel Flow in GREEN ARC
- Flaps ..... 0% (UP)
- Airspeed ..... 120 KIAS

• Note •

Rate-of-Climb values shown are change in altitude in ft per unit time expressed in Feet per Minute.

For operation in air colder than this table provides, use the coldest (left-most) data shown.

For operation in air warmer than this table provides, use caution.

Aircraft with optional Air Conditioning System: Maximum rate of climb performance is reduced by approximately 50 feet per minute if system is ON.

For maximum climb performance the air-conditioner should be off.

Weight	Press Altitude	Climb Speed	RATE OF CLIMB ~ Feet per Minute						
			Temperature ~°C						
LB	FT	KIAS	-40	-20	0	20	40	50	ISA
3600	S.L.	120	1635	1465	1298	1133	970	890	1174
	2000	120	1580	1410	1243	1079	917	836	1153
	4000	120	1524	1355	1189	1025	863	783	1131
	6000	120	1469	1301	1135	971	810	730	1110
	8000	120	1414	1246	1081	918	757	677	1089
	10000	120	1359	1191	1027	864	703	624	1067
	12000	120	1304	1137	973	811	650	571	1046
	14000	120	1249	1083	919	757	597	518	1025
	16000	120	1194	1028	865	704	544	465	1003
	18000	120	1140	974	811	650	491	412	982
	20000	120	1085	920	758	597	439	360	961
	22000	120	1064	698	353	27			855
	24000	120	799	438	98				666
25000	120	668	309					571	
2900	S.L.	120	2045	1822	1630	1456	1289	1206	1498
	2000	120	1964	1768	1594	1427	1262	1179	1502
	4000	120	1908	1731	1566	1401	1233	1146	1508
	6000	120	1869	1704	1540	1370	1193	1100	1515
	8000	120	1841	1677	1508	1329	1137	1037	1517
	10000	120	1815	1646	1466	1271	1060	949	1512
	12000	120	1784	1603	1405	1189	956	833	1496
	14000	120	1742	1541	1320	1079	819	682	1466
	16000	120	1680	1454	1205	934	643	491	1418
	18000	120	1593	1336	1054	749	424	255	1348
	20000	120	1473	1180	860	517	156		1253
	22000	120	1314	979	618	235			1130
	24000	120	1109	729	323				975
25000	120	988	583	154				884	

## Time, Fuel & Distance to Climb: Full Power Climb

**Conditions:**

- Power ..... Full Throttle
- Mixture ..... Maintain Fuel Flow in GREEN ARC
- Weight ..... 3600 LB
- Winds ..... Zero
- Climb Airspeed ..... 120 KIAS

• Note •

Taxi Fuel - Add 1.5 gallon for start, taxi, and takeoff.

Temperature - Add 10% to computed values for each 10° C above standard.

Fuel flow must be maintained in the dynamic green arc, per AFM Full Power Climb: Rich of Peak Technique procedure.

Press Alt FT	OAT (ISA) °C	Climb Speed KIAS	TIME, FUEL, DISTANCE ~ From Sea Level		
			Time Minutes	Fuel U.S. Gal	Distance NM
S.L.	15	120	0.0	0.0	0.0
1000	13	120	0.9	0.5	1.7
2000	11	120	1.7	1.0	3.5
3000	9	120	2.6	1.6	5.4
4000	7	120	3.5	2.1	7.2
5000	5	120	4.4	2.6	9.2
6000	3	120	5.3	3.2	11.1
7000	1	120	6.2	3.7	13.2
8000	-1	120	7.1	4.3	15.2
9000	-3	120	8.0	4.8	17.4
10000	-5	120	9.0	5.4	19.5
11000	-7	120	9.9	6.0	21.8
12000	-9	120	10.9	6.5	24.1
13000	-11	120	11.9	7.1	26.4
14000	-13	120	12.8	7.7	28.9
15000	-15	120	13.8	8.3	31.4
16000	-17	120	14.8	8.9	33.9
17000	-19	120	15.8	9.5	36.5
18000	-21	120	16.8	10.1	39.2
19000	-23	120	17.9	10.7	42.0
20000	-25	120	18.9	11.3	44.9
21000	-27	120	20.0	11.9	47.8
22000	-29	120	21.2	12.6	51.1
23000	-31	120	22.5	13.3	54.9
24000	-33	120	24.0	14.2	59.4
25000	-35	120	25.7	15.1	64.6

## Time, Fuel & Distance to Climb: Cruise Climb

**Conditions:**

- Power ..... 30.5" MAP
- Mixture ..... Target Fuel flow or less
- Weight ..... 3600 LB
- Winds ..... Zero
- Climb Airspeed ..... 120 KIAS

• Note •

Taxi Fuel - Add 1.5 gallon for start, taxi, and takeoff.

Temperature - Add 10% to computed values for each 10° C above standard.

Fuel flow must be leaned to target fuel flow or less, per AFM Cruise Climb: Lean of Peak Technique procedure.

If temperatures do not promote lean of peak climb, use AFM Full Power Climb: Rich of Peak Technique procedures and tables.

Press Alt	OAT (ISA)	Climb Speed	TIME, FUEL, DISTANCE ~ From Sea Level		
			Time Minutes	Fuel U.S. Gal	Distance NM
FT	°C	KIAS			
S.L.	15	120	0.0	0.0	0.0
1000	13	120	1.1	0.3	2.2
2000	11	120	2.2	.07	4.4
3000	9	120	3.3	1.0	6.7
4000	7	120	4.4	1.3	9.1
5000	5	120	5.5	1.7	11.5
6000	3	120	6.7	2.0	14.0
7000	1	120	7.8	2.4	16.6
8000	-1	120	9.0	2.7	19.2
9000	-3	120	10.2	3.1	21.9
10000	-5	120	11.4	3.5	24.7
11000	-7	120	12.6	3.8	27.6
12000	-9	120	13.8	4.2	30.6
13000	-11	120	15.1	4.6	33.6
14000	-13	120	16.3	5.0	36.8
15000	-15	120	17.6	5.4	40.0
16000	-17	120	18.9	5.8	43.3
17000	-19	120	20.2	6.2	46.8
18000	-21	120	21.6	6.6	50.3
19000	-23	120	22.9	7.0	53.8
20000	-25	120	24.1	7.4	57.3
21000	-27	120	25.4	7.7	60.7
22000	-29	120	26.7	8.1	64.5
23000	-31	120	28.2	8.6	68.7
24000	-33	120	29.7	9.1	73.3
25000	-35	120	31.5	9.6	78.6



# Cruise Performance

**Conditions:**

- Weight ..... 3400 LB
- Winds ..... Zero

• Note •

Subtract 10 KTAS if nose wheel pant and fairing removed. Lower KTAS by 10% if nose and main wheel pants and fairings are removed.

Aircraft with optional Air Conditioning System: Cruise performance is reduced by 2 knots. For maximum performance, turn air conditioner off.

*Aircraft with optional Enhanced Vision System:* Cruise performance is reduced by up to 1 knot.

The Values shown in gray in the table below may not be achievable for engine temperature management reasons. This data is provided for purposes of interpolating between points.

CRUISE PERFORMANCE			ISA -30°C		ISA		ISA +30°C	
Altitude (ft MSL)	Power (% of 315)	FF (GPH)	TAS (KTAS)	Econ (nm/gal)	TAS (KTAS)	Econ (nm/gal)	TAS (KTAS)	Econ (nm/gal)
<b>2000</b>	<b>85%</b>	18.3	164	9.0	170	9.3	176	9.6
	<b>75%</b>	16.4	157	9.6	162	9.9	167	10.2
	<b>65%</b>	14.6	148	10.2	154	10.5	158	10.8
	<b>55%</b>	12.7	138	10.9	143	11.2	147	11.5
<b>4000</b>	<b>85%</b>	18.3	168	9.1	174	9.5	179	9.8
	<b>75%</b>	16.4	160	9.7	165	10.1	170	10.4
	<b>65%</b>	14.6	151	10.3	156	10.7	161	11.0
	<b>55%</b>	12.7	140	11.0	145	11.4	149	11.8
<b>6000</b>	<b>85%</b>	18.3	171	9.3	177	9.7	183	10.0
	<b>75%</b>	16.4	163	9.9	168	10.2	174	10.6
	<b>65%</b>	14.6	153	10.5	159	10.9	163	11.2
	<b>55%</b>	12.7	143	11.2	147	11.6	152	11.9
<b>8000</b>	<b>85%</b>	18.3	174	9.5	180	9.8	186	10.2
	<b>75%</b>	16.4	166	10.1	171	10.4	177	10.8
	<b>65%</b>	14.6	156	10.7	161	11.1	166	11.4
	<b>55%</b>	12.7	145	11.4	150	11.8	154	12.1
<b>10000</b>	<b>85%</b>	18.3	177	9.7	184	10.0	190	10.4
	<b>75%</b>	16.4	169	10.3	175	10.6	180	11.0
	<b>65%</b>	14.6	159	10.9	164	11.3	169	11.6
	<b>55%</b>	12.7	148	11.6	152	12.0	157	12.3

CRUISE PERFORMANCE			ISA -30°C		ISA		ISA +30°C	
Altitude (ft MSL)	Power (% of 315)	FF (GPH)	TAS (KTAS)	Econ (nm/gal)	TAS (KTAS)	Econ (nm/gal)	TAS (KTAS)	Econ (nm/gal)
12000	85%	18.3	181	9.9	187	10.2	193	10.6
	75%	16.4	172	10.4	178	10.8	183	11.2
	65%	14.6	162	11.1	167	11.5	172	11.8
	55%	12.7	150	11.8	155	12.2	159	12.5
14000	85%	18.3	184	10.0	191	10.4	197	10.8
	75%	16.4	175	10.6	181	11.0	187	11.4
	65%	14.6	165	11.3	170	11.7	175	12.0
	55%	12.7	153	12.0	157	12.4	162	12.7
16000	85%	18.3	187	10.2	194	10.6	201	11.0
	75%	16.4	178	10.8	185	11.2	191	11.6
	65%	14.6	167	11.5	173	11.9	179	12.2
	55%	12.7	155	12.2	160	12.6	164	12.9
18000	85%	18.3	191	10.4	198	10.8	205	11.0
	75%	16.4	181	11.0	188	11.4	194	11.8
	65%	14.6	171	11.7	176	12.1	182	12.5
	55%	12.7	158	12.4	162	12.8	167	13.1
20000	85%	18.3	195	10.6	202	11.0	209	11.4
	80%	17.4	190	10.9	197	11.3	204	11.7
	75%	16.4	185	11.2	192	11.7	198	12.0
	65%	14.6	174	11.9	180	12.3	185	12.7
	55%	12.7	160	12.6	165	13.0	169	13.3
22000	85%	18.3	199	10.8	206	11.3	213	11.6
	80%	17.4	194	11.1	201	11.6	208	12.0
	75%	16.4	188	11.5	195	11.9	202	12.3
	65%	14.6	177	12.1	183	12.5	188	12.9
	55%	12.7	163	12.8	168	13.2	172	13.5
24000	85%	18.3	202	11.1	210	11.5	218	11.9
	80%	17.4	197	11.4	205	11.8	212	12.2
	75%	16.4	192	11.7	199	12.1	206	12.5
	65%	14.6	180	12.3	186	12.8	191	13.1
	55%	12.7	165	13.0	170	13.4	174	13.7

CRUISE PERFORMANCE			ISA -30°C		ISA		ISA +30°C	
Altitude (ft MSL)	Power (% of 315)	FF (GPH)	TAS (KTAS)	Econ (nm/gal)	TAS (KTAS)	Econ (nm/gal)	TAS (KTAS)	Econ (nm/gal)
<b>25000</b>	<b>85%</b>	18.3	204	11.2	213	11.6	220	12.0
	<b>80%</b>	17.4	199	11.5	207	11.9	214	12.3
	<b>75%</b>	16.4	194	11.8	201	12.2	208	12.6
	<b>65%</b>	14.6	181	12.4	188	12.9	193	13.2
	<b>55%</b>	12.7	166	13.1	171	13.5	176	13.8

## Range / Endurance: Full Power Climb

**Conditions:**

- Mixture.....Best Economy - Target Fuel Flow or less
- Weight ..... 3600 LB for Climb, Avg 3400 LB for Cruise
- Winds.....Zero
- Total Fuel ..... 92 Gallons

• Note •

Fuel Remaining for Cruise is equal to 92.0 gallons usable, less 1.5 gallons (pre-takeoff fuel consumed), 11 gallons (45 minute IFR reserve at 65% power), and listed volume for fuel consumed in Full Power Climb.

Range is decreased by 5% if nose wheel pant and fairings removed.

Range is decreased by 15% of nose wheel and main wheel pants and fairings removed.

For aircraft with optional Air Conditioning System: range is decreased by 1% if system in operation.

Aircraft with optional Enhanced Vision System: range is decreased by ½%.

Range / Endurance: 85% Power Cruise - Full Power Climb							
Press Alt FT	Climb Fuel Gal	Fuel Remaining For Cruise Gal	Airspeed KTAS	Fuel Flow GPH	Endurance Hours	Range NM	Specific Range Nm/Gal
2000	1.0	78.5	170	18.3	4.3	734	9.3
4000	2.1	77.5	174	18.3	4.2	742	9.5
6000	3.2	76.4	177	18.3	4.2	749	9.7
8000	4.3	75.3	180	18.3	4.1	756	9.8
10000	5.4	74.2	184	18.3	4.0	763	10.0
12000	6.5	73.0	187	18.3	4.0	770	10.2
14000	7.7	71.9	191	18.3	3.9	777	10.4
16000	8.9	70.7	194	18.3	3.9	784	10.6
18000	10.1	69.4	198	18.3	3.8	791	10.8
20000	11.3	68.2	202	18.3	3.7	798	11.0
22000	12.6	66.9	206	18.3	3.7	805	11.3
24000	14.2	65.4	210	18.3	3.6	810	11.5
25000	15.1	64.4	213	18.3	3.5	812	11.6

Range / Endurance: 75% Power Cruise - Full Power Climb							
Press Alt FT	Climb Fuel Gal	Fuel Remaining For Cruise Gal	Airspeed KTAS	Fuel Flow GPH	Endurance Hours	Range NM	Specific Range Nm/Gal
2000	1.0	78.5	162	16.4	4.8	779	9.9
4000	2.1	77.5	165	16.4	4.7	786	10.1
6000	3.2	76.4	168	16.4	4.6	793	10.2
8000	4.3	75.3	171	16.4	4.6	800	10.4
10000	5.4	74.2	175	16.4	4.5	807	10.6
12000	6.5	73.0	178	16.4	4.4	814	10.8
14000	7.7	71.9	181	16.4	4.4	821	11.0
16000	8.9	70.7	185	16.4	4.3	827	11.2
18000	10.1	69.4	188	16.4	4.2	834	11.4
20000	11.3	68.2	192	16.4	4.2	841	11.7
22000	12.6	66.9	195	16.4	4.1	847	11.9
24000	14.2	65.4	199	16.4	4.0	852	12.1
25000	15.1	64.4	201	16.4	3.9	853	12.2

Range / Endurance: 65% Power Cruise - Full Power Climb							
Press Alt FT	Climb Fuel Gal	Fuel Remaining For Cruise Gal	Airspeed KTAS	Fuel Flow GPH	Endurance Hours	Range NM	Specific Range Nm/Gal
2000	1.0	78.5	153	14.6	5.4	828	10.5
4000	2.1	77.5	156	14.6	5.3	835	10.7
6000	3.2	76.4	159	14.6	5.2	842	10.9
8000	4.3	75.3	161	14.6	5.2	848	11.1
10000	5.4	74.2	164	14.6	5.1	855	11.3
12000	6.5	73.0	167	14.6	5.0	861	11.5
14000	7.7	71.9	170	14.6	4.9	868	11.7
16000	8.9	70.7	173	14.6	4.8	874	11.9
18000	10.1	69.4	176	14.6	4.8	879	12.1
20000	11.3	68.2	180	14.6	4.7	885	12.3
22000	12.6	66.9	183	14.6	4.6	890	12.5

Range / Endurance: 65% Power Cruise - Full Power Climb							
Press Alt	Climb Fuel	Fuel Remaining For Cruise	Airspeed	Fuel Flow	Endurance	Range	Specific Range
FT	Gal	Gal	KTAS	GPH	Hours	NM	Nm/Gal
24000	14.2	65.4	186	14.6	4.5	893	12.8
25000	15.1	64.4	188	14.6	4.4	894	12.9

Range / Endurance: 55% Power Cruise - Full Power Climb							
Press Alt	Climb Fuel	Fuel Remaining For Cruise	Airspeed	Fuel Flow	Endurance	Range	Specific Range
FT	Gal	Gal	KTAS	GPH	Hours	NM	Nm/Gal
2000	1.0	78.5	143	12.7	6.2	884	11.2
4000	2.1	77.5	145	12.7	6.1	890	11.4
6000	3.2	76.4	147	12.7	6.0	896	11.6
8000	4.3	75.3	150	12.7	5.9	902	11.8
10000	5.4	74.2	152	12.7	5.8	908	12.0
12000	6.5	73.0	155	12.7	5.7	913	12.2
14000	7.7	71.9	157	12.7	5.6	918	12.4
16000	8.9	70.7	160	12.7	5.6	922	12.6
18000	10.1	69.4	162	12.7	5.5	926	12.8
20000	11.3	68.2	165	12.7	5.4	930	13.0
22000	12.6	66.9	168	12.7	5.3	933	13.2
24000	14.2	65.4	170	12.7	5.1	934	13.4
25000	15.1	64.4	171	12.7	5.1	932	13.5

## Range / Endurance: Cruise Climb

**Conditions:**

- Mixture ..... Best Economy - Target Fuel Flow or less
- Weight ..... 3600 LB for Climb, Avg 3400 LB for Cruise
- Winds ..... Zero
- Total Fuel.....92 Gallons

• Note •

Fuel Remaining for Cruise in this table is based on AFM Cruise Climb: Lean of Peak Technique; if Full Power Climb: Rich of Peak Technique is performed, use Range/Endurance: Full Power Climb tables.

Fuel Remaining for Cruise is equal to 92.0 gallons usable, less 1.5 gallons (pre-takeoff fuel consumed), 11 gallons (45 minute IFR reserve at 65% power), and listed volume for fuel consumed in Full Power Climb.

Range is decreased by 5% if nose wheel pant and fairings removed.

Range is decreased by 15% of nose wheel and main wheel pants and fairings removed.

For aircraft with optional air conditioning System: range is decreased by 1% if system in operation.

Aircraft with optional Enhanced Vision System: range is decreased by ½%.

Range / Endurance: 85% Power Cruise - Cruise Climb							
Press Alt	Climb Fuel	Fuel Remaining For Cruise	Airspeed	Fuel Flow	Endurance	Range	Specific Range
FT	Gal	Gal	KTAS	GPH	Hours	NM	Nm/Gal
2000	0.7	78.9	170	18.3	4.3	739	9.3
4000	1.3	78.2	174	18.3	4.3	751	9.5
6000	2.0	77.5	177	18.3	4.2	763	9.7
8000	2.7	76.8	180	18.3	4.2	775	9.8
10000	3.5	76.1	184	18.3	4.2	788	10.0
12000	4.2	75.3	187	18.3	4.1	801	10.2
14000	5.0	74.6	191	18.3	4.1	813	10.4
16000	5.8	73.8	194	18.3	4.0	827	10.6
18000	6.6	73.0	198	18.3	4.0	840	10.8
20000	7.4	72.2	202	18.3	3.9	854	11.0
22000	8.1	71.4	206	18.3	3.9	869	11.3
24000	9.1	70.5	210	18.3	3.8	883	11.5

Range / Endurance: 85% Power Cruise - Cruise Climb							
Press Alt	Climb Fuel	Fuel Remaining For Cruise	Airspeed	Fuel Flow	Endurance	Range	Specific Range
FT	Gal	Gal	KTAS	GPH	Hours	NM	Nm/Gal
25000	9.6	69.9	213	18.3	3.8	890	11.6

Range / Endurance: 75% Power Cruise - Cruise Climb							
Press Alt	Climb Fuel	Fuel Remaining For Cruise	Airspeed	Fuel Flow	Endurance	Range	Specific Range
FT	Gal	Gal	KTAS	GPH	Hours	NM	Nm/Gal
2000	0.7	78.9	162	16.4	4.8	784	9.9
4000	1.3	78.2	165	16.4	4.8	796	10.1
6000	2.0	77.5	168	16.4	4.7	808	10.2
8000	2.7	76.8	171	16.4	4.7	820	10.4
10000	3.5	76.1	175	16.4	4.6	833	10.6
12000	4.2	75.3	178	16.4	4.6	845	10.8
14000	5.0	74.6	181	16.4	4.5	859	11.0
16000	5.8	73.8	185	16.4	4.5	872	11.2
18000	6.6	73.0	188	16.4	4.4	885	11.4
20000	7.4	72.2	192	16.4	4.4	899	11.7
22000	8.1	71.4	195	16.4	4.3	913	11.9
24000	9.1	70.5	199	16.4	4.3	927	12.1
25000	9.6	69.9	201	16.4	4.3	934	12.2

Range / Endurance: 65% Power Cruise - Cruise Climb							
Press Alt	Climb Fuel	Fuel Remaining For Cruise	Airspeed	Fuel Flow	Endurance	Range	Specific Range
FT	Gal	Gal	KTAS	GPH	Hours	NM	Nm/Gal
2000	0.7	78.9	153	14.6	5.4	833	10.5
4000	1.3	78.2	156	14.6	5.4	845	10.7
6000	2.0	77.5	159	14.6	5.3	857	10.9
8000	2.7	76.8	161	14.6	5.3	869	11.1



Range / Endurance: 65% Power Cruise - Cruise Climb							
Press Alt FT	Climb Fuel Gal	Fuel Remaining For Cruise Gal	Airspeed KTAS	Fuel Flow GPH	Endurance Hours	Range NM	Specific Range Nm/Gal
10000	3.5	76.1	164	14.6	5.2	882	11.3
12000	4.2	75.3	167	14.6	5.2	894	11.5
14000	5.0	74.6	170	14.6	5.1	907	11.7
16000	5.8	73.8	173	14.6	5.1	920	11.9
18000	6.6	73.0	176	14.6	5.0	933	12.1
20000	7.4	72.2	180	14.6	4.9	946	12.3
22000	8.1	71.4	183	14.6	4.9	959	12.5
24000	9.1	70.5	186	14.6	4.8	972	12.8
25000	9.6	69.9	188	14.6	4.8	978	12.9

Range / Endurance: 55% Power Cruise - Cruise Climb							
Press Alt FT	Climb Fuel Gal	Fuel Remaining For Cruise Gal	Airspeed KTAS	Fuel Flow GPH	Endurance Hours	Range NM	Specific Range Nm/Gal
2000	0.7	78.9	143	12.7	6.2	889	11.2
4000	1.3	78.2	145	12.7	6.1	900	11.4
6000	2.0	77.5	147	12.7	6.1	912	11.6
8000	2.7	76.8	150	12.7	6.0	924	11.8
10000	3.5	76.1	152	12.7	6.0	936	12.0
12000	4.2	75.3	155	12.7	5.9	948	12.2
14000	5.0	74.6	157	12.7	5.9	959	12.4
16000	5.8	73.8	160	12.7	5.8	971	12.6
18000	6.6	73.0	162	12.7	5.7	982	12.8
20000	7.4	72.2	165	12.7	5.7	994	13.0
22000	8.1	71.4	168	12.7	5.6	1005	13.2
24000	9.1	70.5	170	12.7	5.5	1016	13.4
25000	9.6	69.9	171	12.7	5.5	1021	13.5

# Balked Landing Climb Gradient

**Conditions:**

- Power ..... Full Throttle
- Mixture..... Full Rich
- Flaps..... 100% (DN)
- Climb Airspeed .....  $V_{REF}$

• Note •

Climb Gradient values shown are the gain in altitude for the horizontal distance traversed expressed as Feet per Nautical Mile.

For operation in air colder than this table provides, use the coldest (left-most) data shown.

For operation in air warmer than this table provides, use caution.

Weight LB	Press Alt FT	Climb Speed ( $V_{REF}$ ) KIAS	CLIMB GRADIENT ~ Feet/Nautical Mile					
			Temperature ~°C					
			-20	0	20	40	50	ISA
3600	SL	79	1111	921	751	596	524	792
	2000	79	1015	835	674	528	459	744
	4000	79	924	754	602	463	398	699
	6000	79	838	678	534	402	341	655
	8000	79	758	606	470	346	287	613
	10000	79	682	539	410	293	237	573
2900	SL	79	1519	1274	1057	861	771	1109
	2000	79	1394	1164	959	775	689	1049
	4000	79	1277	1061	868	694	612	991
	6000	79	1168	965	783	618	541	936
	8000	79	1066	874	703	547	474	883
	10000	79	970	790	628	481	412	832

## Balked Landing Rate of Climb

**Conditions:**

- Power ..... Full Throttle
- Mixture ..... Full Rich
- Flaps ..... 100% (DN)
- Climb Airspeed .....  $V_{REF}$

• Note •

Rate-of-Climb values shown are change in altitude in ft per unit time expressed in Feet per Minute

For operation in air colder than this table provides, use the coldest (life-times) data shown.

For operation in air warmer than this table provides, use caution.

Weight  LB	Press Alt  FT	Climb Speed ( $V_{REF}$ ) KIAS	RATE OF CLIMB - Feet per Minute					
			Temperature ~°C					
			-20	0	20	40	50	ISA
3600	SL	79	1344	1163	986	811	725	1030
	2000	79	1276	1096	919	745	659	998
	4000	79	1208	1028	852	679	594	966
	6000	79	1140	961	786	613	528	934
	8000	79	1072	894	719	548	463	903
	10000	79	1005	827	653	482	397	871
2900	SL	79	1812	1592	1377	1166	1062	1431
	2000	79	1732	1514	1300	1090	986	1396
	4000	79	1653	1436	1224	1014	911	1361
	6000	79	1575	1359	1147	939	836	1327
	8000	79	1497	1282	1072	864	762	1293
	10000	79	1420	1206	996	790	688	1259

# Landing Distance

**Conditions:**

- Winds.....Zero
- Runway..... Dry, Level, Paved
- Flaps..... 100%, 50% or 0%
- Power ..... 3° Power Approach  
to 50 FT obstacle, then reduce power passing the estimated 50 foot point and smoothly continue power reduction to reach idle just prior to touchdown.

• Note •

The following factors are to be applied to the computed landing distance for the noted condition:

Headwind - Subtract 10% from table distances for each 13 knots headwind.

Tailwind - Add 10% to table distances for each 2 knots tailwind up to 10 knots.

Grass Runway, Dry - Add 20% to ground roll distance.

Grass Runway, Wet - Add 60% to ground roll distance.

Sloped Runway - Increase table distances by 27% of the ground roll distance for each 1% of downslope. Decrease table distances by 9% of the ground roll distance for each 1% of upslope.

• Note •

The above corrections for runway slope are required to be included herein. These corrections should be used with caution since published runway slope data is usually the net slope from one end of the runway to the other. Many runways will have portions of their length at greater or lesser slopes than the published slope, lengthening (or shortening) landing ground roll estimated from the table.

For operation in outside air temperatures colder than this table provides, use coldest data shown.

For operation in outside air temperatures warmer than this table provides, use caution.

# Landing Distance - Flaps 100%

<b>WEIGHT:</b> 3600 LB	<b>Headwind:</b> Subtract 10% for each 13 knots headwind.
<b>Speed over 50 Ft Obstacle:</b> 79 KIAS	<b>Tailwind:</b> Add 10% for each 2 knots tailwind up to 10 knots.
<b>Flaps:</b> 100%	<b>Runway Slope:</b> Reference Notes
<b>Power:</b> Idle	<b>Dry Grass:</b> Add 20% to Ground Roll
<b>Runway:</b> Dry, Paved, Level	<b>Wet Grass:</b> Add 60% to Ground Roll

PRESS ALT FT	DISTANCE FT	TEMPERATURE ~°C						ISA
		0	10	20	30	40	50	
SL	Grnd Roll	1117	1158	1198	1239	1280	1321	1178
	Total	2447	2505	2565	2625	2685	2747	2535
1000	Grnd Roll	1158	1200	1243	1285	1327	1370	1213
	Total	2506	2567	2630	2693	2757	2821	2585
2000	Grnd Roll	1201	1245	1289	1333	1377	1421	1250
	Total	2568	2633	2699	2765	2832	2900	2636
3000	Grnd Roll	1246	1292	1337	1383	1428	1474	1287
	Total	2635	2702	2771	2841	2911	2983	2691
4000	Grnd Roll	1293	1340	1388	1435	1482	1530	1326
	Total	2705	2776	2848	2922	2996	3070	2748
5000	Grnd Roll	1342	1391	1440	1489	1539	1588	1367
	Total	2779	2854	2930	3007	3085	3163	2808
6000	Grnd Roll	1393	1444	1495	1546	1598	1649	1409
	Total	2857	2936	3016	3097	3179	3261	2871
7000	Grnd Roll	1447	1500	1553	1606	1659	1712	1453
	Total	2941	3024	3108	3193	3279	3365	2937
8000	Grnd Roll	1503	1558	1613	1668	1724	1779	1499
	Total	3029	3116	3205	3294	3384	3475	3006
9000	Grnd Roll	1562	1619	1677	1734	1791	1848	1546
	Total	3122	3214	3307	3401	3496	3592	3079
10000	Grnd Roll	1624	1683	1743	1802	1862	1921	1595
	Total	3221	3318	3416	3515	3614	3715	3155

## Landing Distance - Flaps 50%

<b>WEIGHT:</b> 3600 LB <b>Speed over 50 Ft Obstacle:</b> 87 KIAS <b>Flaps:</b> 50% <b>Power:</b> Idle <b>Runway:</b> Dry, Paved, Level		<b>Headwind:</b> Subtract 10% for each 13 knots headwind. <b>Tailwind:</b> Add 10% for each 2 knots tailwind up to 10 knots. <b>Runway Slope:</b> Reference Notes <b>Dry Grass:</b> Add 20% to Ground Roll <b>Wet Grass:</b> Add 60% to Ground Roll						
PRESS ALT FT	DISTANCE  FT	TEMPERATURE ~°C						
		0	10	20	30	40	50	ISA
SL	Grnd Roll	1166	1209	1251	1294	1337	1379	1230
	Total	2681	2745	2810	2875	2942	3010	2777
1000	Grnd Roll	1209	1253	1298	1342	1386	1430	1267
	Total	2745	2813	2881	2950	3020	3091	2833
2000	Grnd Roll	1254	1300	1346	1392	1438	1484	1305
	Total	2814	2885	2957	3029	3103	3178	2892
3000	Grnd Roll	1301	1349	1396	1444	1491	1539	1344
	Total	2886	2961	3037	3113	3191	3269	2954
4000	Grnd Roll	1350	1399	1449	1498	1548	1597	1385
	Total	2963	3042	3121	3202	3283	3366	3019
5000	Grnd Roll	1401	1453	1504	1555	1607	1658	1427
	Total	3045	3127	3211	3296	3382	3468	3087
6000	Grnd Roll	1455	1508	1561	1615	1668	1721	1472
	Total	3131	3218	3306	3395	3485	3576	3158
7000	Grnd Roll	1511	1566	1622	1677	1732	1788	1517
	Total	3223	3314	3407	3501	3595	3691	3233
8000	Grnd Roll	1570	1627	1685	1742	1800	1857	1565
	Total	3320	3416	3514	3612	3712	3812	3312
9000	Grnd Roll	1631	1691	1751	1810	1870	1930	1614
	Total	3423	3524	3627	3731	3835	3941	3395
10000	Grnd Roll	1695	1758	1820	1882	1944	2006	1666
	Total	3532	3639	3747	3856	3966	4077	3481

# Landing Distance - Flaps 0%

<b>WEIGHT:</b> 3600 LB	<b>Headwind:</b> Subtract 10% for each 13 knots headwind.
<b>Speed over 50 Ft Obstacle:</b> 94 KIAS	<b>Tailwind:</b> Add 10% for each 2 knots tailwind up to 10 knots.
<b>Flaps:</b> 0%	<b>Runway Slope:</b> Reference Notes
<b>Power:</b> Idle	<b>Dry Grass:</b> Add 20% to Ground Roll
<b>Runway:</b> Dry, Paved, Level	<b>Wet Grass:</b> Add 60% to Ground Roll

PRESS ALT FT	DISTANCE FT	TEMPERATURE ~°C						ISA
		0	10	20	30	40	50	
SL	Grnd Roll	1365	1415	1465	1515	1565	1615	1440
	Total	3165	3241	3319	3398	3478	3558	3280
1000	Grnd Roll	1415	1467	1519	1571	1623	1675	1483
	Total	3242	3323	3404	3487	3571	3656	3347
2000	Grnd Roll	1468	1522	1576	1629	1683	1737	1527
	Total	3324	3409	3495	3582	3670	3759	3418
3000	Grnd Roll	1523	1579	1635	1690	1746	1802	1574
	Total	3411	3500	3590	3682	3775	3868	3491
4000	Grnd Roll	1581	1638	1696	1754	1812	1870	1621
	Total	3503	3597	3692	3788	3885	3984	3569
5000	Grnd Roll	1641	1701	1761	1821	1881	1941	1671
	Total	3600	3699	3799	3900	4003	4106	3650
6000	Grnd Roll	1703	1766	1828	1890	1953	2015	1723
	Total	3703	3807	3913	4019	4127	4236	3736
7000	Grnd Roll	1769	1834	1899	1963	2028	2093	1776
	Total	3813	3922	4033	4145	4258	4373	3825
8000	Grnd Roll	1838	1905	1972	2040	2107	2174	1832
	Total	3929	4044	4161	4279	4398	4518	3919
9000	Grnd Roll	1910	1980	2049	2119	2189	2259	1890
	Total	4052	4173	4296	4420	4545	4671	4018
10000	Grnd Roll	1985	2058	2130	2203	2276	2348	1950
	Total	4183	4310	4439	4569	4701	4833	4122

Intentionally Left Blank



# Section 6: **Weight and Balance Data**

## Table of Contents

Introduction .....	3
Loading Instructions .....	4
Weight and Balance Loading Form.....	5
Loading Data.....	6
Moment Limits.....	7
Weight & Balance Record.....	8
Equipment List .....	9

Intentionally Left Blank

## Introduction

This section describes the procedure for calculating the weight and moment for various operations. A comprehensive list of all equipment available for this airplane is included at the back of this section.

It should be noted that specific information regarding the weight, arm, moment, and installed equipment for this airplane as delivered from the factory can be found at the back of this section.

It is the responsibility of the pilot to ensure that the airplane is loaded properly. All changes to the basic empty weight and center of gravity are the responsibility of the operator.

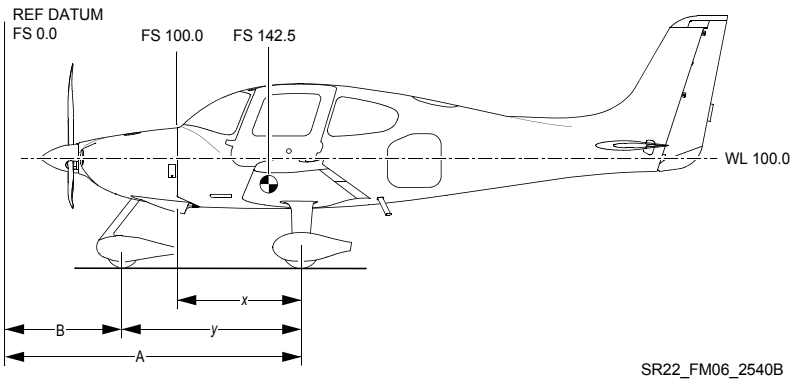

Basic empty weight, moment, and center of gravity are provided in inches aft of datum, where 0 inches datum is 100.0 inches forward of the cabin firewall. CG can also be expressed in terms of its location as a percentage of the airplane Mean Aerodynamic Cord (MAC) using the following formula:

$$CG\% \text{ MAC} = 100 \times (CG \text{ Inches} - LEMAC) / MAC$$

Where:

$$LEMAC = 133.1$$

$$MAC = 47.7$$

• Note •

Leveling and Weighing procedures are not described in this section. Refer to Airplane Maintenance Manual (AMM), Chapter 8, Leveling and Weighing.

## Loading Instructions

It is the responsibility of the pilot to ensure that the airplane is properly loaded and operated within the prescribed weight and center of gravity limits. The following information enables the pilot to calculate the total weight and moment for the loading. The calculated moment is then compared to the Moment Limits chart or table (*Figure 6-3*) for a determination of proper loading.

Airplane loading determinations are calculated using the Weight & Balance Loading Form (*Figure 6-1*), the Loading Data chart and table (*Figure 6-2*), and the Moment Limits chart and table (*Figure 6-3*).

1. **Basic Empty Weight** – Enter the current Basic Empty Weight and Moment from the Weight & Balance Record (*Figure 6-4*).
2. **Front Seat Occupants** – Enter the total weight and moment/1000 for the front seat occupants from the Loading Data (*Figure 6-2*).
3. **Rear Seat Occupants** – Enter the total weight and moment/1000 for the rear seat occupants from the Loading Data (*Figure 6-2*).
4. **Baggage** – Enter weight and moment for the baggage from the Loading Data (*Figure 6-2*).
  - If desired, subtotal the weights and moment/1000 from steps 1 through 4. This is the *Zero Fuel Condition*. It includes all useful load items excluding fuel.
5. **Fuel Loading** – Enter the weight and moment of usable fuel loaded on the airplane from the Loading Data (*Figure 6-2*).
  - Subtotal the weight and moment/1000. This is the *Ramp Condition* or the weight and moment of the aircraft before taxi.
6. **Fuel for start, taxi, and run-up** – This value is pre-entered on the form. Normally, fuel used for start, taxi, and run-up is approximately 9 pounds at an average moment/1000 of 1.394.
7. **Takeoff Condition** – Subtract the weight and moment/1000 for step 8 (start, taxi, and run-up) from the Ramp Condition values (step 7) to determine the Takeoff Condition weight and moment/1000.
  - The total weight at takeoff must not exceed the maximum weight limit of 3600 pounds. The total moment/1000 must not be above the maximum or below the minimum moment/1000 for the Takeoff Condition Weight as determined from the Moment Limits chart or table (*Figure 6-3*).

# Weight and Balance Loading Form

• Note •

The Takeoff Condition Weight must not exceed 3600 lb.

The Takeoff Condition Moment must be within the Minimum Moment to Maximum Moment range at the Takeoff Condition Weight. (Refer to *Moment Limits*).

Serial Num: \_\_\_\_\_ Date: \_\_\_\_\_

Reg. Num: \_\_\_\_\_ Initials: \_\_\_\_\_

Item	Description	Weight LB	Moment/ 1000
1.	Basic Empty Weight <i>Includes unusable fuel &amp; full oil</i>		
2.	Front Seat Occupants <i>Pilot &amp; Passenger (total)</i>		
3.	Rear Seat Occupants		
4.	Baggage Area <i>130 lb maximum</i>		
5.	Zero Fuel Condition Weight <i>Sub total item 1 thru 4 3400 lb maximum</i>		
6.	Fuel Loading <i>92 Gallon @ 6.0 lb/gal. Maximum</i>		
7.	Ramp Condition Weight <i>Sub total item 5 and 6</i>		
8.	Fuel for start, taxi, and run-up (negative number) <i>Normally 9 lb at average moment of 1394 (1.4).</i>		
9.	Takeoff Condition Weight <i>Subtract item 8 from item 7</i>		

Figure 6-1

# Loading Data

Use the following chart or table to determine the moment/1000 for fuel and payload items to complete the Loading Form.

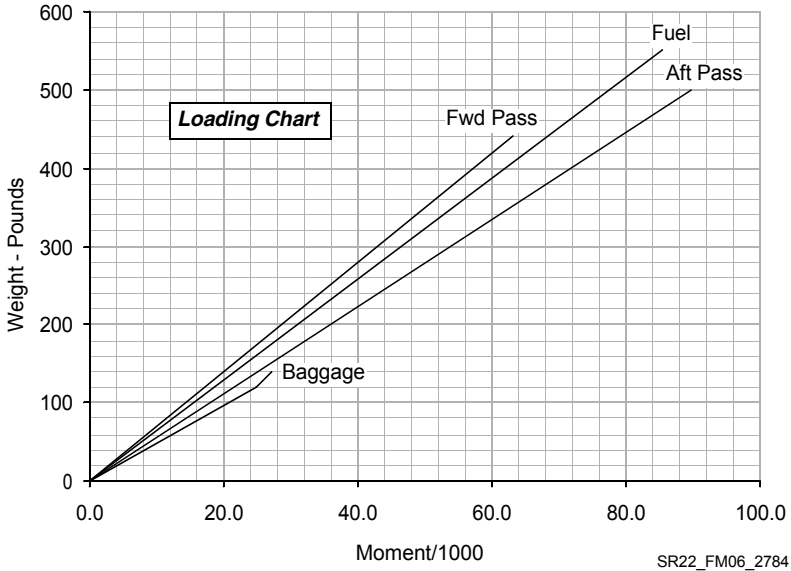

SR22\_FM06\_2784

Weight LB	Fwd Pass FS 143.5	Aft Pass FS 180.0	Baggage FS 208.0	Fuel FS 154.9	Weight LB	Fwd Pass FS 143.5	Aft Pass FS 180.0	Fuel FS 154.9
20	2.9	3.6	4.2	3.1	300	43.1	54.0	46.5
40	5.7	7.2	8.3	6.2	320	45.9	57.6	49.6
60	8.6	10.8	12.5	9.3	340	48.8	61.2	52.7
80	11.5	14.4	16.6	12.4	360	51.7	64.8	55.8
100	14.4	18.0	20.8	15.5	380	54.5	68.4	58.9
120	17.2	21.6	25.0	18.6	400	57.4	72.0	62.0
140	20.1	25.2	27.04*	21.7	420	60.3	75.6	65.1
160	23.0	28.8		24.8	440	63.1	79.2	68.2
180	25.8	32.4		27.9	460		82.8	71.3
200	28.7	36.0		31.0	480		86.4	74.4
220	31.6	39.6		34.1	500		90.0	77.5
240	34.4	43.2		37.2	520			80.5
260	37.3	46.8		40.3	552**			85.5
280	40.2	50.4		43.4				

\*130 lb Maximum

\*\*92 U.S. Gallons Usable

Figure 6-2

## Moment Limits

Use the following chart or table to determine if the weight and moment from the completed Weight and Balance Loading Form (Figure 6-1) are within limits.

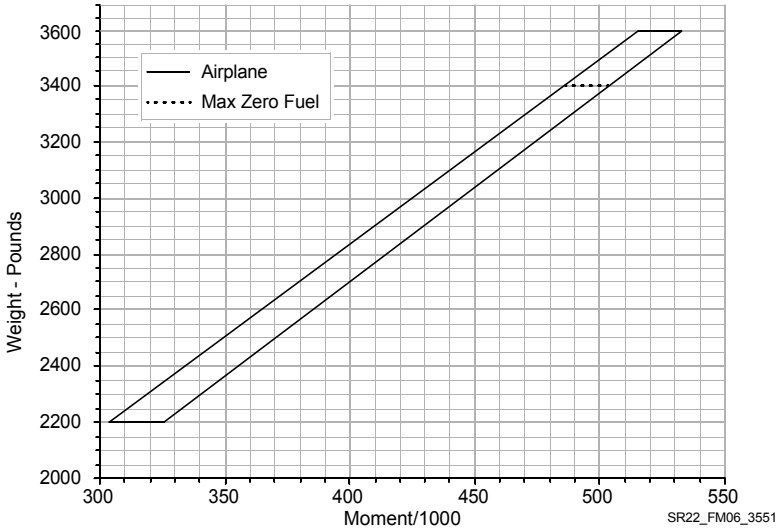

Weight LB	Moment/1000		Weight LB	Moment/1000	
	Minimum	Maximum		Minimum	Maximum
2200	304	326	2950	414	437
2250	311	333	3000	422	444
2300	318	341	3050	430	452
2350	325	348	3100	438	459
2400	332	356	3150	445	467
2450	340	363	3200	453	474
2500	347	370	3250	461	481
2550	354	378	3300	469	489
2600	361	385	3350	477	496
2650	368	393	*3400	484	504
2700	375	400	3450	494	511
2750	383	407	3500	501	519
2800	391	415	3550	508	526
2850	399	422	3600	515	533
2900	407	430			

\*NOTE: Maximum zero fuel weight.

Figure 6-3





## Equipment List

This list will be determined after the final equipment has been installed in the aircraft.

Intentionally Left Blank

# ***Section 7: Systems Description***

## **Table of Contents**

Introduction .....	5
Airframe .....	6
Fuselage .....	6
Wings .....	6
Empennage .....	7
Flight Controls .....	8
Elevator System .....	8
Aileron System .....	10
Rudder System .....	12
Control Locks .....	12
Instrument Panel .....	14
Pilot Panel Arrangement .....	14
Center Console Arrangement .....	14
Bolster Panel Arrangement .....	14
Flight Instruments .....	17
Attitude Indicator .....	19
Airspeed Indicator .....	20
Altimeter .....	21
Horizontal Situation Indicator .....	22
Vertical Speed Indicator .....	23
Magnetic Compass .....	24
Wing Flaps .....	24
Flap Control Switch .....	24
Landing Gear .....	26
Main Gear .....	26
Nose Gear .....	26
Brake System .....	26
Baggage Compartment .....	28
Baggage Tie-Downs/Cargo Net .....	28
Seats .....	29
Front Seats .....	29
Rear Seats .....	29
Seat Belt and Shoulder Harness .....	30
Cabin Doors .....	32
Windshield and Windows .....	32
Engine .....	33

Engine Controls .....	33
Engine Indicating .....	35
Engine Lubrication System .....	38
Ignition and Starter System.....	38
Air Induction System .....	39
Engine Exhaust System.....	39
Engine Fuel Injection .....	39
Engine Cooling.....	40
Propeller .....	41
Fuel System .....	42
Fuel Selector Valve .....	43
Fuel Pump Operation.....	43
Fuel Indicating.....	45
Electrical System.....	49
Power Generation .....	49
Power Distribution.....	52
Electrical System Protection .....	53
Electrical System Control.....	57
Ground Service Receptacle .....	58
Electrical Indicating .....	59
Lighting Systems.....	61
Exterior Lighting .....	61
Interior Lighting .....	62
Convenience Lighting .....	64
Environmental System .....	66
Distribution .....	66
Heating.....	67
Cooling.....	68
Airflow Selection .....	71
Vent Selection.....	71
Temperature Selection.....	72
Stall Warning System.....	74
Pitot-Static System .....	75
Pitot Heat Switch.....	75
Pitot Heat Annunciation .....	75
Alternate Static Source .....	75
Avionics.....	78
Perspective Integrated Avionics System.....	78
Avionics Support Equipment.....	95
Cabin Features.....	98
Emergency Locator Transmitter.....	98
Fire Extinguisher .....	99

Hour Meters ..... 100  
Emergency Egress Hammer ..... 100  
Convenience Outlet(s) ..... 100  
Cirrus Airframe Parachute System ..... 102  
System Description ..... 102  
Activation Handle ..... 103  
Deployment Characteristics ..... 104

Intentionally Left Blank

## Section 7 - Systems Description

### Landing Gear

#### Main Gear

*Serials w/ tubeless tire:*

Each main gear wheel has a 15 x 6.00 x 6 tubeless tire installed.

#### Nose Gear

*Serials w/ tubeless tire:*

The tubeless nosewheel tire measures 5.00 x 5.

#### Brake System

*Serials w/ Beringer Brake System:*

The reservoir is serviced with MIL-PRF-87257 hydraulic fluid.

A temperature sensor is mounted to each brake assembly and provides measured brake temperatures to the avionics system for caution and warning annunciation.

Intentionally Left Blank



# Section 7 - Systems Description

## Electrical System

Illustration On Following Page

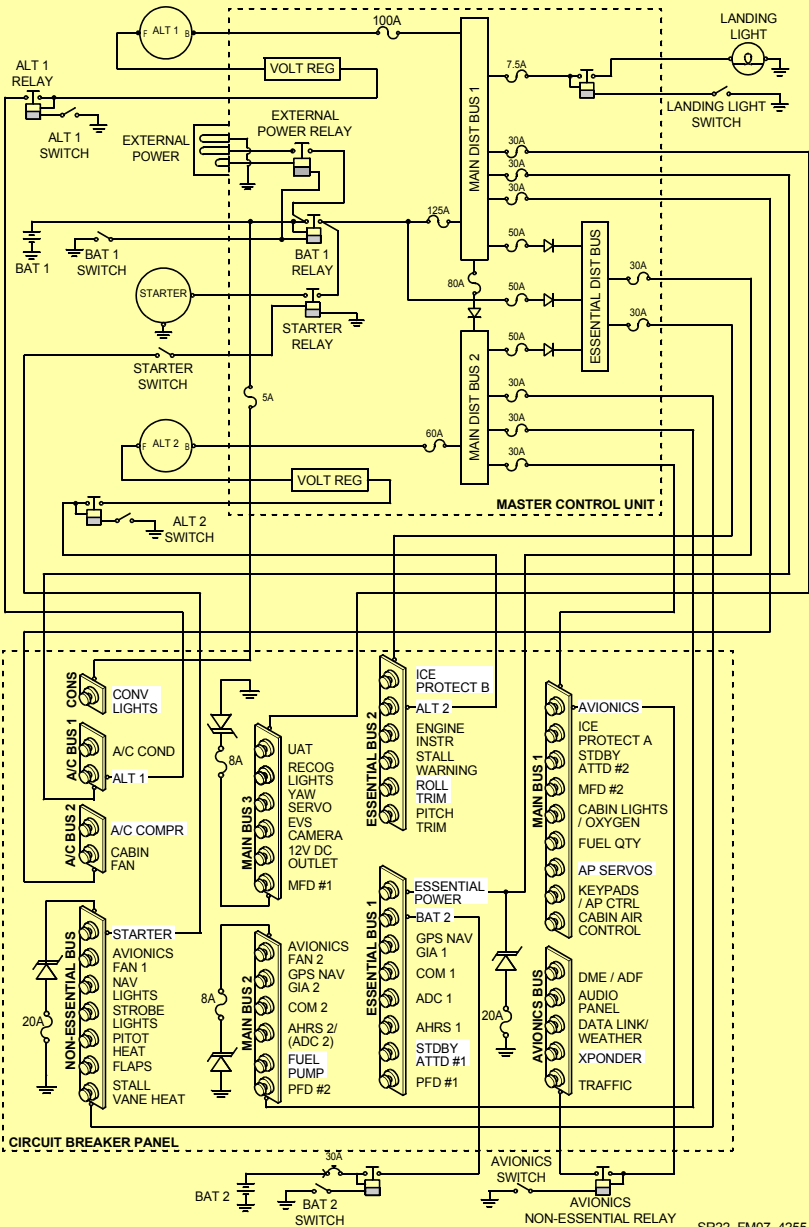

SR22\_FM07\_4255

**Figure 7-10**  
**Electrical System Schematic - Serials 1233 & subs**

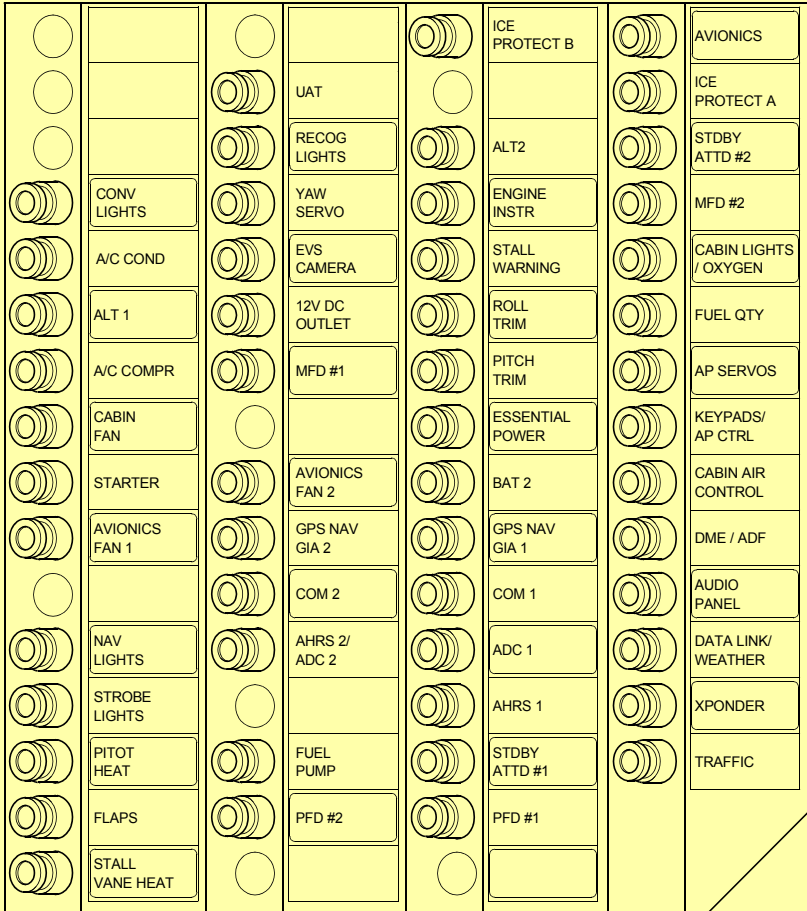

SR22\_FM07\_4247

**Figure 7-11**  
**Circuit Breaker Panel - Serials 1233 & subs**

# Avionics

## Perspective Integrated Avionics System

The Perspective Integrated Avionics System provides advanced cockpit functionality and improved situational awareness through the use of fully integrated flight, engine, communication, navigation and monitoring equipment. The system consists of the following components:

- GDU Primary Flight Display (PFD)
- GDU Multifunction Display (MFD)
- GCU 478 Flight Management System Keyboard
- GRS 77 Attitude and Heading Reference System
- GDC 74A Air Data Computer
- GIA 63W Integrated Avionics Units
- GEA 71 Engine Airframe Unit
- GTX 32 Mode A, C, or GTX 33 Mode S, or GTX 33 ES Mode S with Extended Squitter (Optional)
- GMA 350 or 350c (Optional) Audio Panel w/ Marker Beacon Receiver
- GFC 700 3-Axis Autopilot and GMC 705 Controller
- GSR 56 Iridium Global Satellite Datalink (Optional)
- GDL 69/69A XM Satellite Weather/Radio Receiver (Optional)
  - GRT 10 XM Radio Remote Transceiver (Optional)
  - GRC 10 XM Radio Remote Control (Optional)
- Flight Stream 210 Bluetooth™ Transceiver (Optional)
- GDL 88 UAT/ADS-B Transceiver (Optional)
- Traffic Advisory System (Optional)
- Weather Information System (Optional)
- Bendix/King KR 87 Automatic Direction Finder (Optional)
- Bendix/King KN 63 Distance Measuring Equipment (Optional)
- Synthetic Vision System (Optional)
- Max Viz Enhanced Vision System (Optional)
- MD302 Standby Attitude Module (Optional)

Refer to the Perspective Integrated Avionics System Pilot's Guide for a detailed description of the system and its operating modes.

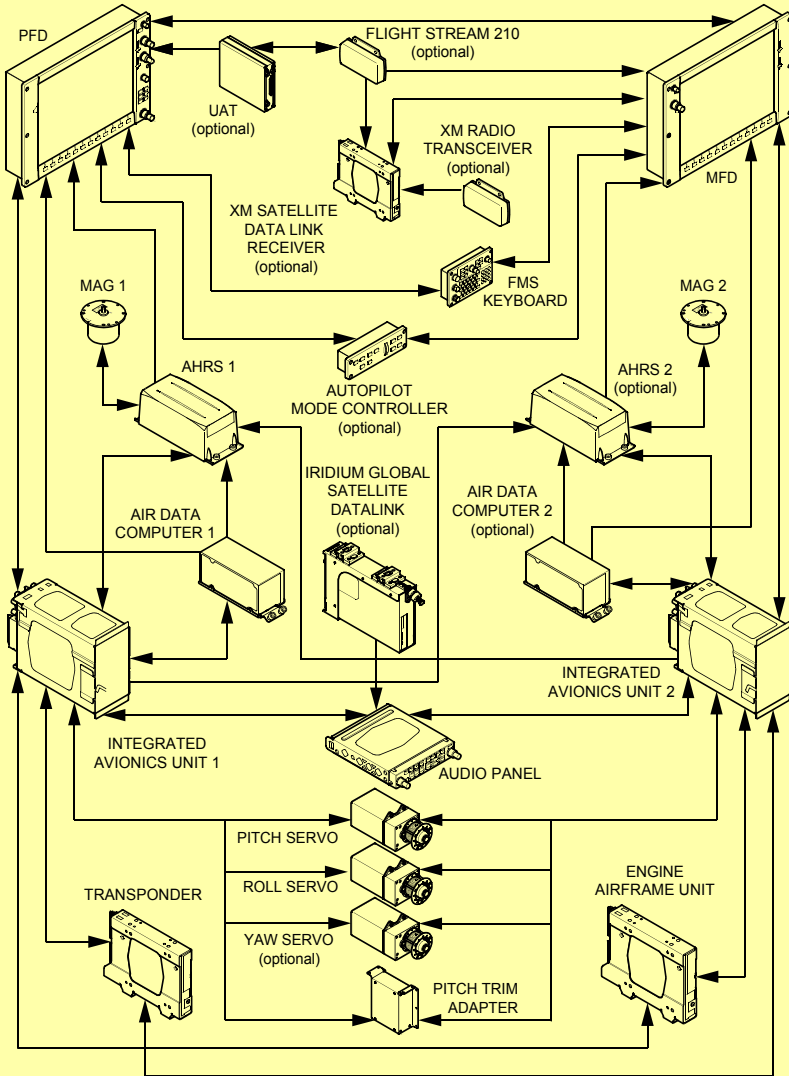

SR22\_FM07\_4233B

**Figure 7-17**  
**Perspective Integrated Avionics System Schematic**

### ***GDL 88 UAT/ADS-B Transceiver***

The GDL 88 UAT consists of a Transceiver mounted under the LH crew seat and an antenna installed on the bottom of the fuselage.

The GDL 88 is a universal access transceiver (UAT) that performs the following functions:

- UAT Transmission: The GDL 88 transmits ADS-B OUT data on the 978 MHz frequency to be received by other aircraft, vehicles, and air traffic control (ATC) for situational and traffic awareness.
- UAT Reception: The GDL 88 receives ADS-B, ADS-R, and TIS-B data transmitted on the 978 MHz frequency from other aircraft, vehicles, and ground stations for traffic awareness. In addition, the GDL 88 receives FIS-B data to provide graphical and textual weather products.
- Mode-S Extended Squitter (ES) Reception: The GDL 88 receives ADS-B data transmitted by aircraft on the 1090 MHz frequency for traffic awareness.
- Output of graphical traffic and weather data to the MFD and PFD (ADS-B IN).

The GDL 88 UAT/ADS-B Transceiver directly interfaces with the PFD, GIA 63W integrated avionics units, and Flight Stream 210 (if installed).

28 VDC for GDL 88 UAT/ADS-B Transceiver operation is supplied through the 5-amp UAT circuit breaker on MAIN BUS 3.

For a complete description of the GDL 88 UAT/ADS-B Transceiver system, its operating modes, and additional detailed operating procedures, refer to the Perspective Integrated Avionics System Pilot's Guide.

Intentionally Left Blank



# Section 7 - Systems Description

## Avionics

### Perspective Integrated Avionics System

The Perspective Integrated Avionics System provides advanced cockpit functionality and improved situational awareness through the use of fully integrated flight, engine, communication, navigation and monitoring equipment. The system consists of the following components:

- GDU Primary Flight Display (PFD)
- GDU Multifunction Display (MFD)
- GCU 478 Flight Management System Keyboard
- GRS 77 Attitude and Heading Reference System
- GDC 74A Air Data Computer
- GIA 63W Integrated Avionics Units
- GEA 71 Engine Airframe Unit
- GTX 32 Mode A, C, or GTX 33 Mode S, or GTX 33 ES Mode S with Extended Squitter (Optional)
- GMA 350 or 350c (Optional) Audio Panel w/ Marker Beacon Receiver
- GFC 700 3-Axis Autopilot and GMC 705 Controller
- GSR 56 Iridium Global Satellite Datalink (Optional)
- GDL 69/69A XM Satellite Weather/Radio Receiver (Optional)
  - GRT 10 XM Radio Remote Transceiver (Optional)
  - GRC 10 XM Radio Remote Control (Optional)
- Flight Stream 210 Bluetooth™ Transceiver (Optional)
- GDL 88 UAT/ADS-B Transceiver (Optional)
- Traffic Advisory System (Optional)
- Weather Information System (Optional)
- Bendix/King KR 87 Automatic Direction Finder (Optional)
- Bendix/King KN 63 Distance Measuring Equipment (Optional)
- Synthetic Vision System (Optional)
- Max Viz Enhanced Vision System (Optional)

- MD302 Standby Attitude Module (Optional)

Refer to the Perspective Integrated Avionics System Pilot's Guide for a detailed description of the system and its operating modes.

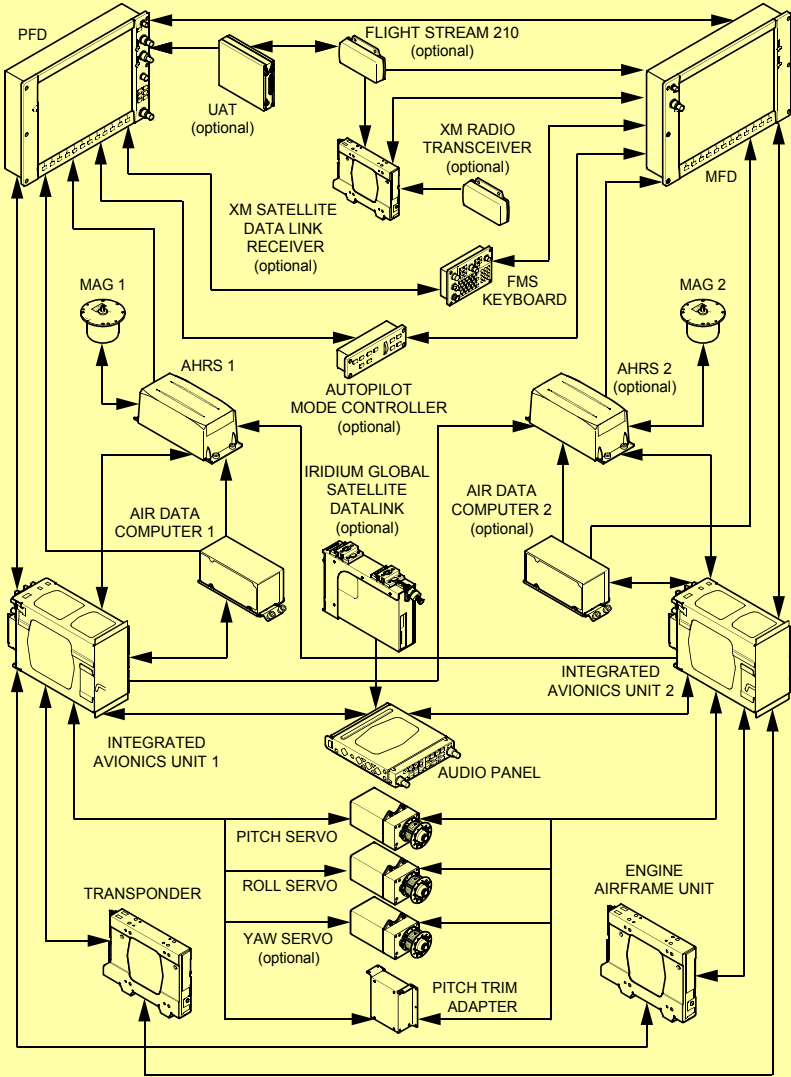

SR22\_FM07\_4233B

**Figure 7-17**  
**Perspective Integrated Avionics System Schematic**

### ***Flight Stream 210 Bluetooth™ Transceiver***

The optionally installed Flight Stream 210 Bluetooth™ Transceiver (wireless avionics interface) includes an internal Attitude and Heading Reference System (AHRS) and pressure transducer from which it can compute supplemental pitch, roll, heading, and altitude data to be broadcast to a compatible mobile device.

#### **• Caution •**

Flight Stream 210 AHRS information is not to be used as a primary source of aircraft attitude information.

Data output from the Flight Stream 210 can be used to provide additional situational awareness for the pilot and passengers. Flight plans can be transferred between compatible mobile devices and the integrated avionics system using supported mobile applications.

The Flight Stream 210 also serves as a wireless GDL 69 controller through which the aircraft crew or passengers can select Sirius/XM audio channels and control volume. Up to four Bluetooth™ devices can be paired to the Flight Stream 210. It is mounted in the aft avionics bay and is hard-wire connected to the Perspective Integrated Avionics System.

28 VDC for Flight Stream 210 operation is supplied through the 5-amp DATA LINK/WEATHER circuit breaker on the Avionics Non-Essential Bus.

For a complete description of the Flight Stream 210 system, its operating modes, and additional detailed operating procedures, refer to the Perspective Integrated Avionics System Pilot's Guide.

### ***GMA 350 or 350c Audio Panel with Marker Beacon Receiver***

The 350 or 350c Audio Panel, installed on the center console below the Flight Management System Keyboard, integrates NAV/COM digital audio, intercom and marker beacon controls. The VHF communications portion of the unit interfaces with both Integrated Avionics Units to provide external radio communication, receive and demodulate VOR, Localizer, and Glide Slope signals.

28 VDC for Audio Panel operation is supplied through the 5-amp AUDIO PANEL circuit breaker on the AVIONICS bus.

• Note •

COM swap mode is not available in this installation.

For a detailed operating instructions, refer to the GMA 350 or 350c Audio Panel Pilot's Guide.

## **Optional Avionics**

### ***GDL 69/69A XM Satellite Weather and Radio***

The Data Link Satellite Receiver, mounted in the empennage avionics compartment, receives and transmits real-time weather information to the MFD and PFD.

*Serials 0442 thru 1232:* If GDL 69A option is installed, this unit also provides digital XM audio entertainment to the cabin audio system via the audio panel. It is controlled by the MFD or the GRT 10 XM Remote Transceiver with GRC 10 Remote Control.

*Serials 1233 & subs:* If GDL 69A option is installed, this unit also provides digital XM audio entertainment to the cabin audio system via the audio panel. It is controlled by MFD or the Flight Stream 210 Bluetooth™ Transceiver with compatible mobile devices.

28 VDC for Satellite Datalink Receiver operation is supplied through the 5-amp WEATHER/DATA LINK circuit breaker on AVIONICS BUS. Refer to the Perspective Integrated Avionics System Pilot's Guide for a complete description of the system, its operating modes, and additional detailed operating procedures.

Intentionally Left Blank

## Introduction

This section provides a basic description and operation of the standard airplane and its systems. Optional equipment described within this section is identified as optional.

• Note •

Some optional equipment may not be described in this section. For description and operation of optional equipment not described in this section, refer to [Section 9: Log of Supplements](#).

## Airframe

### Fuselage

The airplane's monocoque fuselage is constructed primarily of composite materials and is designed to be aerodynamically efficient. The cabin area is bounded on the forward side by the firewall at fuselage station 100, and on the rear by the aft baggage compartment bulkhead at fuselage station 222. Comfortable seating is provided for four adults. A composite roll cage within the fuselage structure provides roll protection for the cabin occupants. The cabin and baggage compartment floors are constructed of a foam core composite with access to under-floor components.

All flight and static loads are transferred to the fuselage structure from the wings and control surfaces through four wing attach points in two locations under the front seats and two locations on the sidewall just aft of the rear seats.

The lower firewall employs a 20° bevel to improve crashworthiness. In addition, an avionics bay is located aft of bulkhead 222 and accessible through an access panel installed on the RH side of the aft fuselage.

### Wings

The wing structure is constructed of composite materials producing wing surfaces that are smooth and seamless. The wing cross section is a blend of several high performance airfoils. A high aspect ratio results in low drag. Each wing provides attach structure for the main landing gear and contains a 47.25-gallon fuel tank.

The wing is constructed in a conventional spar, rib, and shear section arrangement. The upper and lower skins are bonded to the spar, ribs, and aft shear web forming a torsion box that carries all of the wing bending and torsion loads. The rear shear webs are similar in construction but do not carry through the fuselage. The main spar is laminated epoxy/carbon fiber in a C-section, and is continuous from wing tip to wing tip. The wing spar passes under the fuselage below the two front seats and is attached to the fuselage in two locations. Lift and landing loads are carried by the single carry-through spar, plus a pair of rear shear webs (one on each wing) attached to the fuselage.



## Empennage

The empennage consists of a horizontal stabilizer, a two-piece elevator, a vertical fin and a rudder. All of the empennage components are conventional spar (shear web), rib, and skin construction.

The horizontal stabilizer is a single composite structure from tip to tip. The two-piece elevator, attached to the horizontal stabilizer, is aluminum.

The vertical stabilizer is composite structure integral to the main fuselage shell for smooth transfer of flight loads. The rudder is aluminum and is attached to the vertical stabilizer rear shear web at three hinge points.

## Flight Controls

The airplane uses conventional flight controls for ailerons, elevator and rudder. The control surfaces are pilot controlled through either of two single-handed side control yokes mounted beneath the instrument panel. The location and design of the control yokes allow easy, natural use by the pilot. The control system uses a combination of push rods, cables and bell cranks for control of the surfaces.

### Elevator System

The two-piece elevator provides airplane pitch control. The elevator is of conventional design with skin, spar and ribs manufactured of aluminum. Each elevator half is attached to the horizontal stabilizer at two hinge points and to the fuselage tailcone at the elevator control sector. Elevator motion is generated through the pilot's control yokes by sliding the yoke tubes forward or aft in a bearing carriage. A push-pull linkage is connected to a cable sector mounted on a torque tube. A single cable system runs from the forward elevator sector under the cabin floor to the aft elevator sector pulley. A push-pull tube connected to the aft elevator sector pulley transmits motion to the elevator bellcrank attached to the elevators.

#### *Pitch Trim System*

Pitch trim is provided by adjusting the neutral position of the compression spring cartridge in the elevator control system by means of an electric motor. It is possible to easily override full trim or autopilot inputs by using normal control inputs. A ground adjustable trim tab is installed on the elevator to provide small adjustments in neutral trim.

This tab is factory set and does not normally require adjustment. An electric motor changes the neutral position of the spring cartridge attached to the elevator control horn. A conical trim button located on top of each control yoke controls the motor. Moving the switch forward will initiate nose-down trim and moving the switch aft will initiate nose-up trim. Neutral (takeoff) trim is indicated by the alignment of a reference mark on the yoke tube with a tab attached to the instrument panel bolster. The elevator trim also provides a secondary means of airplane pitch control in the event of a failure in the primary pitch control system not involving a jammed elevator.

Elevator (pitch) trim operates on 28 VDC supplied through the 2-amp PITCH TRIM circuit breaker on ESS BUS 2.

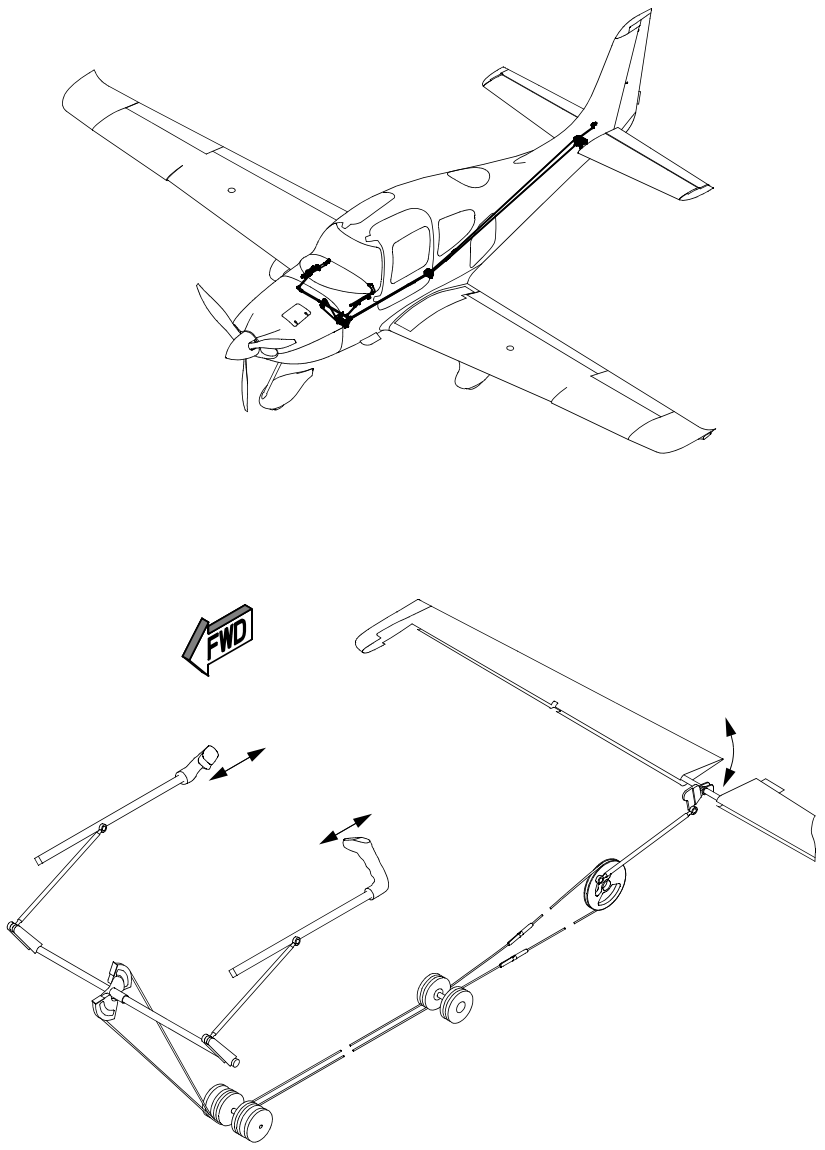

SR22\_FM07\_1461

**Figure 7-1**  
**Elevator System**

## Aileron System

The ailerons provide airplane roll control. The ailerons are of conventional design with skin, spar and ribs manufactured of aluminum. Each aileron is attached to the wing shear web at two hinge points.

Aileron control motion is generated through the pilot's control yokes by rotating the yokes in pivoting bearing carriages. Push rods link the pivoting carriages to a centrally located pulley sector. A single cable system runs from the sector to beneath the cabin floor and aft of the rear spar. From there, the cables are routed in each wing to a vertical sector/crank arm that rotates the aileron through a right angle conical drive arm.

### *Roll Trim System*

Roll trim is provided by adjusting the neutral position of a compression spring cartridge in the aileron control system by means of an electric motor. The electric roll trim is also used by the autopilot to position the ailerons. It is possible to easily override full trim or autopilot inputs by using normal control inputs.

A ground adjustable trim tab is installed on the right aileron to provide small adjustments in neutral trim. This tab is factory set and does not normally require adjustment.

An electric motor changes the neutral position of a spring cartridge attached to the left actuation pulley in the wing. A conical trim button located on top of each control yoke controls the motor. Moving the switch left will initiate left-wing-down trim and moving the switch right will initiate right-wing-down trim. Neutral trim is indicated by the alignment of the line etched on the control yoke with the centering indication marked on the instrument panel. The aileron trim also provides a secondary means of airplane roll control in the event of a failure in the primary roll control system not involving jammed ailerons.

Aileron trim operates on 28 VDC supplied through the 2-amp ROLL TRIM circuit breaker on ESS BUS 2.

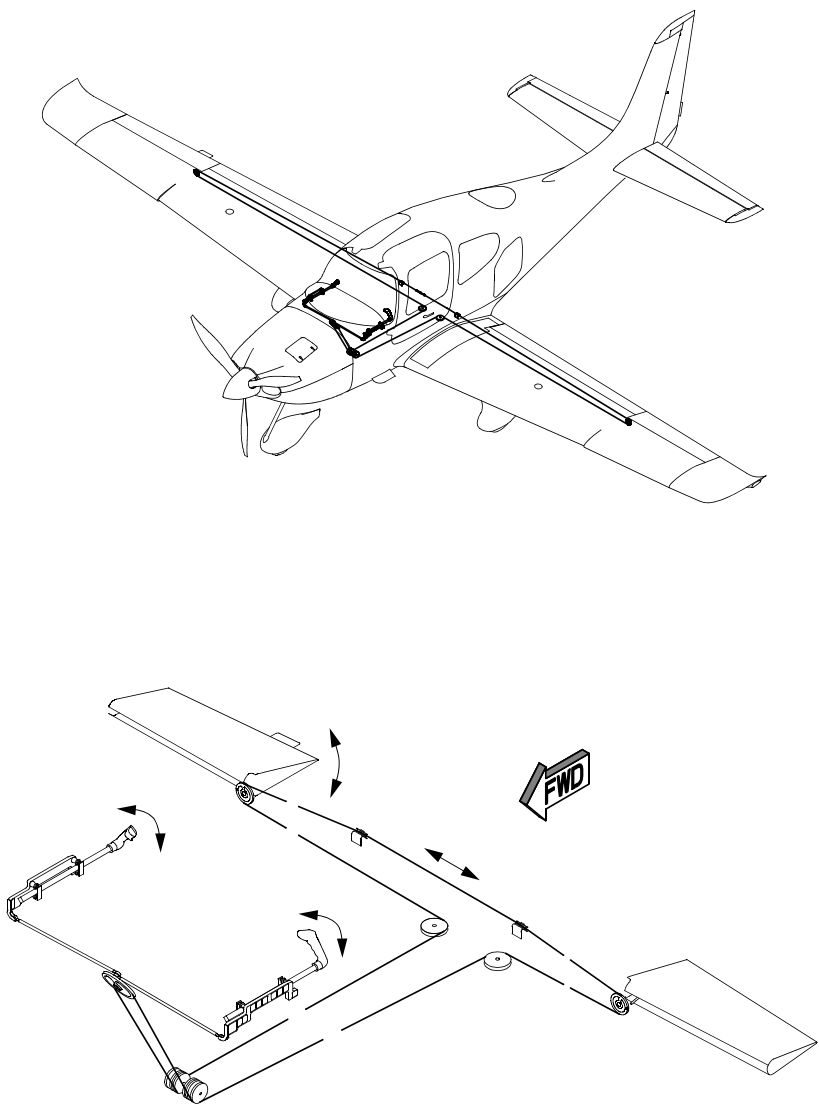

SR22\_FM07\_1462

**Figure 7-2**  
**Aileron System**

## Rudder System

The rudder provides airplane directional (yaw) control. The rudder is of conventional design with skin, spar and ribs manufactured of aluminum. The rudder is attached to the aft vertical stabilizer shear web at three hinge points and to the fuselage tailcone at the rudder control bell crank.

Rudder motion is transferred from the rudder pedals to the rudder by a single cable system under the cabin floor to a sector next to the elevator sector pulley in the aft fuselage. A push-pull tube from the sector to the rudder bell crank translates cable motion to the rudder. Springs and a ground adjustable spring cartridge connected to the rudder pedal assembly tension the cables and provide centering force.

### ***Yaw Trim System***

Yaw trim is provided by spring cartridge attached to the rudder pedal torque tube and console structure. The spring cartridge provides a centering force regardless of the direction of rudder deflection. The yaw trim is ground adjustable only.

A ground adjustable trim tab is installed on the rudder to provide small adjustments in neutral trim. This tab is factory set and does not normally require adjustment.

## Control Locks

The airplane's control system is not equipped with gust locks. The trim spring cartridges have sufficient power to act as a gust damper without rigidly locking the position.

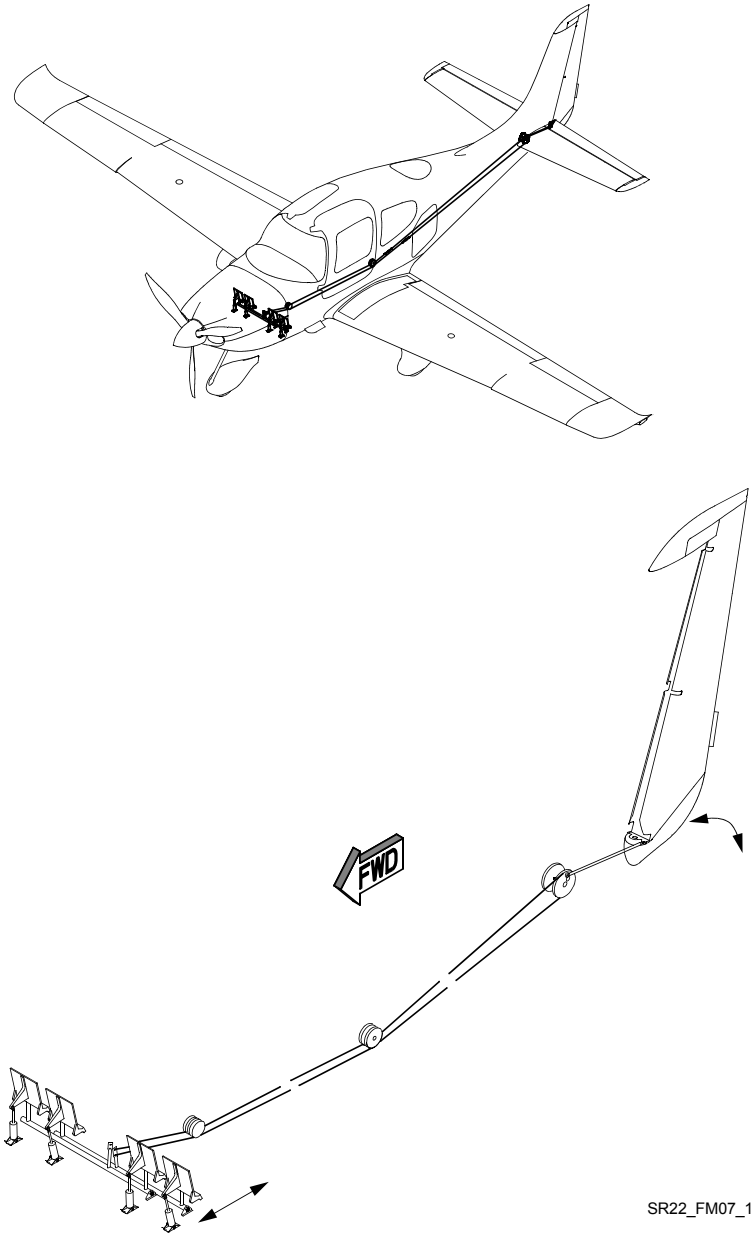

SR22\_FM07\_1463

**Figure 7-3**  
**Rudder System**

## Instrument Panel

The instrument panel is of all metal construction and is installed in sections so equipment can be easily removed for maintenance. The surrounding glareshield is made of composite material and projects over the instrument panel to reduce reflections on the windshield from lighted equipment and to shield the panel equipment from glare.

### Pilot Panel Arrangement

Two color landscape-oriented electronic flight displays are installed to the instrument panel; the Primary Flight Display (PFD) and the Multifunction Display (MFD). The PFD, installed directly in front of the pilot, is intended to be the primary display of flight parameter information (attitude, airspeed, heading, and altitude). The MFD, installed to the right of the PFD, provides supplemental situational and navigation information to the pilot. The ignition switch is located on the left side of the instrument panel. The cabin environmental control switches are located on the right side of the instrument panel. Instrument panel air vents are located on the outboard sections of the panel.

### Center Console Arrangement

A center console contains the Flight Management System Keyboard, autopilot and audio controls, flap system control and indication, fuel selector valve, and the power and mixture levers. System circuit breakers, the alternate static source valve, and the ELT panel switch are located on the left side of the console. A friction knob for adjusting throttle and mixture control feel and position stability is located on the right side of the console. The accessory outlet, map compartment, audio jacks, hour meters, and emergency egress hammer are installed inside the console armrest.

### Arrangement

A switch panel located in the “dash board” bolster below the instrument panel contains the master, avionics power, ice protection (optional), Pitot heat, and exterior and interior lighting switches and controls. The standby airspeed, attitude, and altimeter instruments are located below bolster switch panel.



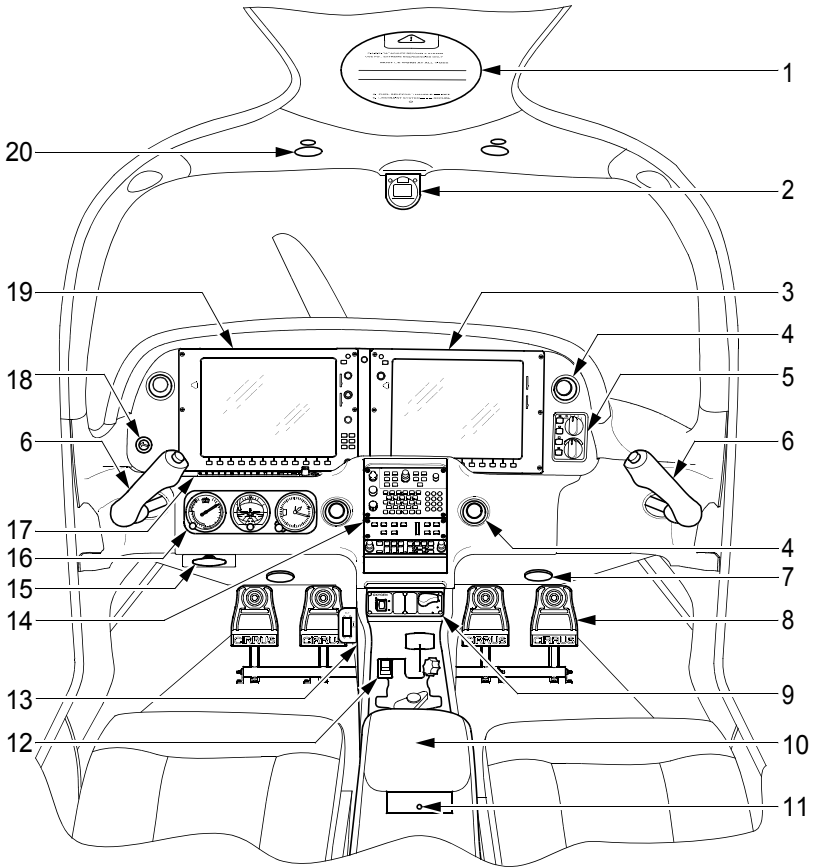

**Legend**

- |  |                                   |
|--|-----------------------------------|
| 1. Cirrus Airframe Parachute System (CAPS) Activation T-Handle Cover | 12. Engine & Fuel System Controls |
| 2. Magnetic Compass  | 13. Left Side Console             |
| 3. Multifunction Display   | · Circuit Breaker Panel           |
| 4. Fresh Air "Eyeball" Outlet  | · ELT Remote Switch               |
| 5. Temperature/Ventilation Controls                                  | · Alternate Static Source         |
| 6. Control Yoke  | 14. Avionics Panel                |
| 7. Conditioned Air Outlet  | 15. Parking Brake                 |
| 8. Rudder Pedals   | 16. Flight Instrument Panel       |
| 9. Flap Control & Position Indicators                                | 17. Bolster Switch Panel          |
| 10. Armrest  | 18. Start/Ignition Key Switch     |
| 11. Passenger Audio Jack(s)  | 19. Primary Flight Display        |
|  | 20. Overhead Light & Switch       |

SR22\_FM07\_3258A

**Figure 7-4**  
**Instrument Panel and Console - Serials w/o MD302 (1 of 2)**

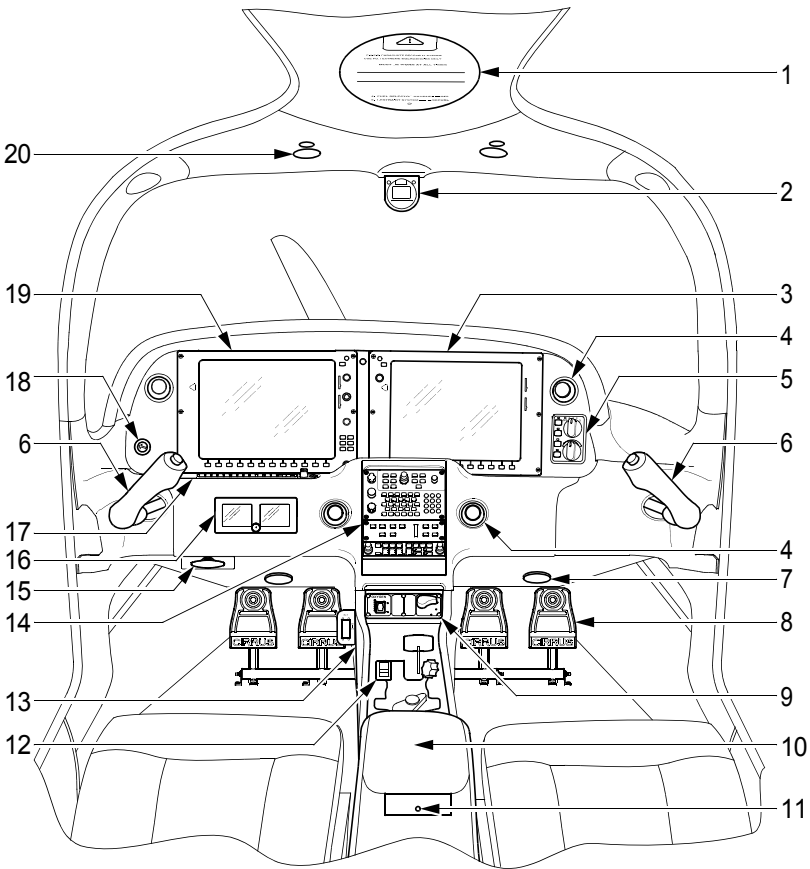

**Legend**

- |   |  |
|---|--|
| <ul style="list-style-type: none"> <li>1. Cirrus Airframe Parachute System (CAPS) Activation T-Handle Cover</li> <li>2. Magnetic Compass</li> <li>3. Multifunction Display</li> <li>4. Fresh Air "Eyeball" Outlet</li> <li>5. Temperature/Ventilation Controls</li> <li>6. Control Yoke</li> <li>7. Conditioned Air Outlet</li> <li>8. Rudder Pedals</li> <li>9. Flap Control &amp; Position Indicators</li> <li>10. Armrest</li> <li>11. Passenger Audio Jack(s)</li> <li>12. Engine &amp; Fuel System Controls</li> </ul> | <ul style="list-style-type: none"> <li>13. Left Side Console                     <ul style="list-style-type: none"> <li>· Circuit Breaker Panel</li> <li>· Alternate Engine Air</li> <li>· ELT Remote Switch</li> <li>· Alternate Static Source</li> </ul> </li> <li>14. Avionics Panel</li> <li>15. Parking Brake</li> <li>16. Flight Instrument Panel</li> <li>17. Bolster Switch Panel</li> <li>18. Start/Ignition Key Switch</li> <li>19. Primary Flight Display</li> <li>20. Overhead Light &amp; Switch</li> </ul> |
|---|--|

SR22\_FM07\_3678

**Figure 7-4**

**Instrument Panel and Console - Serials 0954, 0963 & subs w/ MD302 (2 of 2)**

## Flight Instruments

Flight instruments and annunciations are displayed on the Primary Flight Display (PFD) located directly in front of the pilot. The PFD presents the primary flight instruments arranged in the conventional basic “T” configuration. Standby instruments for airspeed, attitude, and altitude are mounted on the LH bolster panel and are powered independently of the PFD.

Knobs, knob sets, and membrane-type push button switches are located along the inboard edge of the PFD and MFD and provide control for communication (COM), navigation (NAV), heading (HDG), barometric pressure set (BARO), and various Flight Management functions. For electrical requirements and additional information on PFD and MFD integration, refer to the [Perspective Integrated Avionics System](#) description in this section.

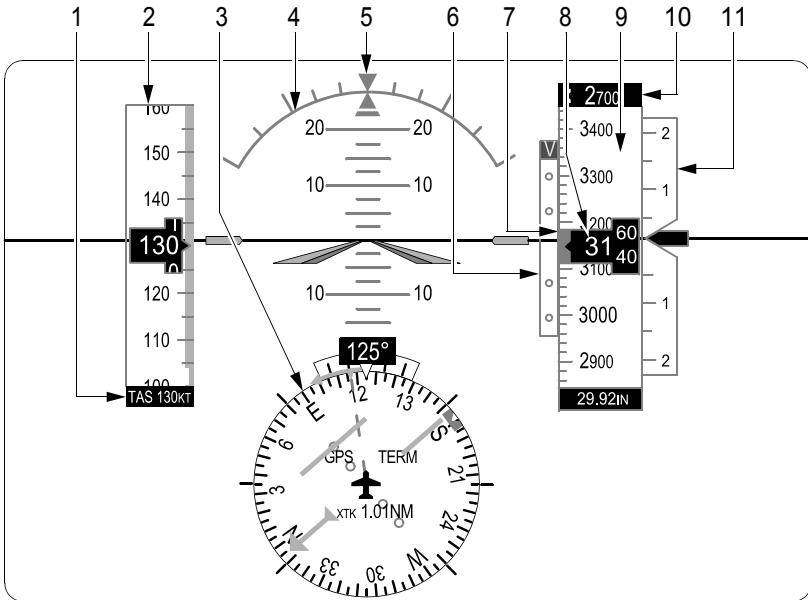

**LEGEND**

1. True Airspeed
2. Airspeed Indicator
3. Horizontal Situation Indicator (HSI)
4. Attitude Indicator
5. Slip/Skid Indicator
6. Vertical Deviation Indicator (VDI)
7. Selected Altitude Bug
8. Current Altitude
9. Altimeter
10. Selected Altitude
11. Vertical Speed Indicator (VSI)
12. Current Heading
13. Lubber Line
14. Selected Heading Bug
15. Flight Phase
16. Navigation Source
17. Aircraft Symbol
18. Course Deviation Scale
19. Rotating Compass Rose
20. Course Pointer

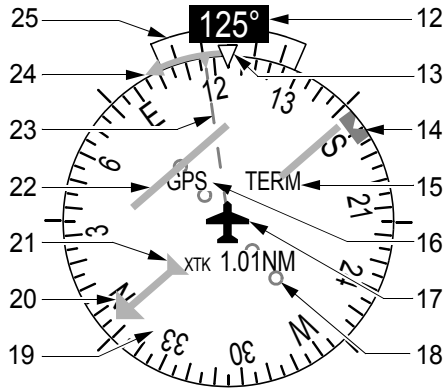

**HSI DETAIL**

21. To/From Indicator
22. Course Deviation Indicator
23. Current Track Indicator
24. Turn Rate/Heading Trend Vector
25. Turn Rate Indicator

SR22\_FM07\_2790

**Figure 7-5  
Flight Instruments**

## Attitude Indicator

The primary attitude indicator is shown on the upper center of the PFD and displays pitch, roll, and slip/skid information provided by the Attitude and Heading Reference System (AHRS).

Above and below the horizon line, major pitch marks and labels are shown for every 10°, up to 80°. Between 25° below and 45° above the horizon line, the pitch index scale is graduated in 5° increments with every 10° of pitch labeled. Between 20° below and 20° above the horizon line, minor pitch marks occur every 2.5°. If pitch limits are exceeded in either the nose-up or nose-down attitude, red warning chevrons will appear and point the way back to level flight. The roll index scale is graduated with major tick marks at 30° and 60° and minor tick marks at 10°, 20°, and 45°. The roll pointer is slaved to the airplane symbol. The slip-skid indicator is the bar beneath the roll pointer. The indicator moves with the roll pointer and moves laterally away from the pointer to indicate lateral acceleration. Slip/skid is indicated by the location of the bar relative to the pointer. One bar displacement is equal to one ball displacement on a traditional slip/skid indicator.

### **Standby Attitude Indicator**

*Serials w/o MD302 Standby Attitude Module:*

The standby attitude indicator is mounted on the LH bolster panel and gives backup indication of flight attitude. Bank attitude is indicated by a pointer at the top of the indicator relative to the bank scale with index marks at 10°, 20°, 30°, 60°, and 90° either side of the center mark. A fixed miniature airplane superimposed over a movable mask containing a white symbolic horizon bar, which divides the mask into two sections, indicates pitch and roll attitudes. The upper “blue sky” section and the lower “earth” sections have pitch reference lines useful for pitch attitude control. A knob at the bottom of the instrument allows adjustment of the miniature airplane to the horizon bar for a more accurate flight attitude indication. A PULL TO CAGE knob on the indicator is used for quick erection of the gyro. When the caging knob is pulled, the pitch and roll indications will align to within 2° of their respective fixed references. The standby attitude indicator is electrically driven. A red GYRO flag indicates loss of electrical power. Redundant circuits paralleled through diodes at the indicator supply DC electrical power for gyro operation.

*Serials 0954, 0963 & subs w/ MD302 Standby Attitude Module:*

The MD302 Standby Attitude Module is mounted on the LH bolster panel and gives backup indication of flight attitude. Bank attitude is indicated by a pointer at the top of the indicator relative to the bank scale with index marks at 0° (triangle), 10°, 20°, 30°, 45° (small triangle), and 60° either side of the center mark. A fixed, user-configurable airplane symbol is superimposed over a movable background containing a white horizon bar that divides the attitude display into two sections: upper “blue sky” and lower “earth”. The pitch scale on the attitude display is graduated in 5° increments. Chevrons appear on the pitch scale at extreme pitch attitudes. The MD302 Standby Attitude Module is electrically driven. A red X indicates the attitude display is absent due to exceedance of internal rate sensors, loss of airspeed, or other reasons. Redundant circuits paralleled through diodes supply DC electrical power to the unit.

*All Serials:*

28 VDC for the standby attitude indicator is supplied through the 5-amp STDBY ATTD 1 circuit breaker on the ESS BUS 1 and the 5-amp STDBY ATTD 2 circuit breaker on the MAIN BUS 1.

## **Airspeed Indicator**

Primary airspeed data is provided by the Air Data Computer and is shown as a vertical tape along the upper left side of the PFD. The airspeed scale is graduated with major tick marks at intervals of 10 knots and minor tick marks at intervals of 5 knots. Speed indication starts at 20 knots, with 56 knots of airspeed viewable at any time. The actual airspeed is displayed inside the black pointer. The pointer remains black until reaching the never-exceed speed ( $V_{NE}$ ), at which point it turns red. Color coded bars are provided to indicate flap operating range, normal operating range, caution range, and never-exceed speed. Speeds above the never-exceed speed, appear in the high speed warning range, represented on the airspeed tape by red/white “barber pole” coloration. Calculated true airspeed is displayed in window at the bottom edge of the airspeed tape. Airspeed trend is also displayed as a bar along side of the airspeed tape.

### ***Standby Airspeed Indicator***

*Serials w/o MD302 Standby Attitude Module:*

The standby airspeed indicator is mounted on the LH bolster panel and displays indicated and true airspeeds on a dual-scale, internally lit

precision airspeed indicator installed in the pilot's instrument panel. The instrument senses difference in static and Pitot pressures and displays the result in knots on an airspeed scale. A single pointer sweeps an indicated airspeed scale calibrated from 40 to 220 knots. The 'zero' index is at the 12 o'clock position. A sub-scale aligns true airspeed with the corresponding indicated airspeed when the altitude/temperature correction is set in the correction window. A knob in the lower left corner of the instrument is used to rotate the pressure altitude scale in the correction window to align the current pressure altitude with the outside air temperature.

*Serials 0954, 0963 & subs w/ MD302 Standby Attitude Module:*

The MD302 Standby Attitude Module is mounted on the LH bolster panel and displays the current Indicated Airspeed (IAS). The instrument senses difference in static and pitot pressures and displays the result in knots in the Airspeed Window. The Airspeed Window/Pointer sweeps the indicated airspeed tape and denotes the current airspeed. Color coded bars are provided to indicate flap operating range, normal operating range, caution range, and never-exceed speed. The airspeed indication markings on the MD302 do not automatically compensate for changes in  $V_{NE}$  or  $V_{NO}$  at altitudes above 17,500 feet.

28 VDC for the MD302 Standby Attitude Module is supplied through the 5-amp STDBY ATTD 1 circuit breaker on the ESS BUS 1 and the 5-amp STDBY ATTD 2 circuit breaker on the MAIN BUS 1.

## Altimeter

Primary altitude data is provided by the Air Data Computer and is shown as a vertical tape along the upper right side of the PFD. The altimeter scale is graduated with major tick marks at intervals of 100 feet and minor tick marks at intervals of 20 feet. Six hundred (600) feet of barometric altitude is viewable at any time.

The local barometric pressure is set using the barometric adjustment knob on the PFD. The selectable altitude reference bug is displayed on the altimeter tape and is set using the altitude selection knob on the Flight Management System Keyboard. Barometric minimum descent altitude (MDA, or Decision Height, DH), can be preset. Altimeter trend is also displayed as a bar along side of the altimeter tape.

The PFD Altitude is corrected for static source position error (normal static source / 0% flaps), the altitude calibration errors for the PFD are zero with flaps up and normal source (typical cruise flight). Calibration

corrections are only necessary when flaps are extended or the alternate static source is selected.

### ***Standby Altimeter***

#### ***Serials w/o MD302 Standby Attitude Module:***

Airplane altitude is depicted on a conventional, three-pointer, internally lit barometric altimeter installed on the LH bolster panel. The instrument senses the local barometric pressure adjusted for altimeter setting and displays the result on the instrument in feet. The altimeter is calibrated for operation between -1000 and 20,000 feet altitude. The scale is marked from 0 to 10 in increments of 2. The long pointer indicates hundreds of feet and sweeps the scale every 1000 feet (each increment equals 20 feet). The short, wide pointer indicates thousands of feet and sweeps the scale every 10,000 feet (each increment equals 200 feet). The short narrow pointer indicates tens of thousands feet and sweeps from 0 (zero) to 2 (20,000 feet with each increment equal to 2000 feet). Barometric windows on the instrument's face allow barometric calibrations in either inches of mercury (in.Hg) or millibars (mb). The barometric altimeter settings are input through the barometric adjustment knob at the lower left of the instrument.

#### ***Serials 0954, 0963 & subs w/ MD302 Standby Attitude Module:***

The MD302 Standby Attitude Module is mounted on the LH bolster panel and displays the current barometric corrected altitude. The instrument senses the local barometric pressure adjusted for altimeter setting and displays the result in the Altitude Window. The altitude units are user-configurable in feet or meters. The Altitude Window/Pointer sweeps the altitude tape and denotes the current BARO-corrected altitude. The BARO Window shows the currently selected barometric altitude. The BARO units are user-configurable in IN HG or MBAR. The barometric setting on the MD302 will automatically synchronize to the setting on the Garmin avionics, and can be manually adjusted by turning the Control Knob while in Flight Mode.

28 VDC for the MD302 Standby Attitude Module is supplied through the 5-amp STDBY ATTD 1 circuit breaker on the ESS BUS 1 and the 5-amp STDBY ATTD 2 circuit breaker on the MAIN BUS 1.

#### ***All Serials:***

The standby altimeter does not have automatic position error corrections, calibration corrections are necessary. Because the PFD has automatic corrections and the standby does not, differences between the two indications are typical (difference is the greatest at



high altitudes and high airspeeds, where the position error corrections are the highest).

## Horizontal Situation Indicator

The horizontal situation indicator is displayed along the lower center of the PFD. Heading data is provided by the Attitude and Heading Reference System (AHRS) and the onboard magnetometers. The HSI displays a rotating compass card in a heading-up orientation. Letters indicate the cardinal points and numeric labels occur every 30°. Major tick marks are at 10° intervals and minor tick marks at 5° intervals. Reference index marks are provided at 45° intervals around the compass card. A circular segment scale directly above the rotating compass card shows half and standard rates of turn based on the length of the turn rate trend vector.

The HSI presents heading, turn rate, course deviation, bearing, and navigation source information in a 360° compass-rose format. The HSI contains a Course Deviation Indicator (CDI) with a course pointer arrow, a To/From arrow, a sliding deviation bar, and scale. The course pointer is a single line arrow (GPS, VOR1, and LOC1) or a double line arrow (VOR2 and LOC2) which points in the direction of the set course. The To/From arrow rotates with the course pointer and is displayed when the active NAVAID is received.

The HSI heading reference bug is set using the heading selection knob on the Flight Management System Keyboard. The selected heading is displayed in a window above the upper LH 45° index mark and will disappear approximately 3 seconds after the heading selection knob stops turning.

The Course Deviation Indicator (CDI) navigation source shown on the HSI is set using the CDI softkey to select GPS, NAV1, or NAV2 inputs. The course pointer is set using the course selection knob on the Flight Management System Keyboard. The selected course is displayed in a window above the upper RH 45° index mark and will disappear approximately 3 seconds after the heading selection knob stops turning.

## Vertical Speed Indicator

Vertical Speed data is provided by the Air Data Computer and is shown as a vertical tape along the right side of the altimeter on the PFD. The VSI scale is graduated with major tick marks at 1000 and 2000 fpm in each direction and minor tick marks at intervals of 500 feet

The vertical speed pointer moves up and down the fixed VSI scale and shows the rate of climb or descent in digits inside the pointer. A reference notch at the RH edge of the scale indicates 0 feet/min. Vertical speed must exceed 100 feet/min before digits will appear in the VSI pointer. If the rate of ascent/descent exceeds 2000 fpm, the pointer appears at the corresponding edge of the tape and the rate appears inside the pointer.

*Serials 0954, 0963 & subs w/ MD302 Standby Attitude Module:*

The Altitude Trend Bar is located along the right margin of the Altitude Display. This feature is optional and can be turned on or off by the user.

## **Magnetic Compass**

A conventional, internally lighted, liquid filled, magnetic compass is installed on the cabin headliner immediately above the windshield. A compass correction card is installed with the compass.

• Note •

Refer to FAA Advisory Circular (AC) 43.13-1B for a list of occasions requiring a compass swing. If a compass swing is required, perform Operational Test - Magnetic Compass Calibration (refer to AMM 34-20, Attitude and Direction).

## Wing Flaps

The electrically controlled, single-slotted flaps provide low-speed lift enhancement. Each flap is manufactured of aluminium and connected to the wing structure at three hinge points. Rub strips are installed on the top leading edge of each flap to prevent contact between the flap and wing flap cove. The flaps are selectively set to three positions: 0%, 50% (16°) and 100% (35.5°) by operating the FLAP control switch. The FLAP control switch positions the flaps through a motorized linear actuator mechanically connected to both flaps by a torque tube. Proximity switches in the actuator limit flap travel to the selected position and provide position indication.

The wing flaps actuator, flap control switch and indicator lights are powered by 28 VDC through the 10-amp FLAPS circuit breaker on the NON ESS BUS.

### Flap Control Switch

An airfoil-shaped FLAPS control switch is located at the bottom of the vertical section of the center console. The control switch is marked and has detents at three positions: UP (0%), 50% and 100%. The appropriate  $V_{FE}$  speed is marked at the Flap 50% and 100% switch positions. Setting the switch to the desired position will cause the flaps to extend or retract to the appropriate setting. An indicator light at each control switch position illuminates when the flaps reach the selected position. The UP (0%) light is green and the 50% and 100% lights are yellow.

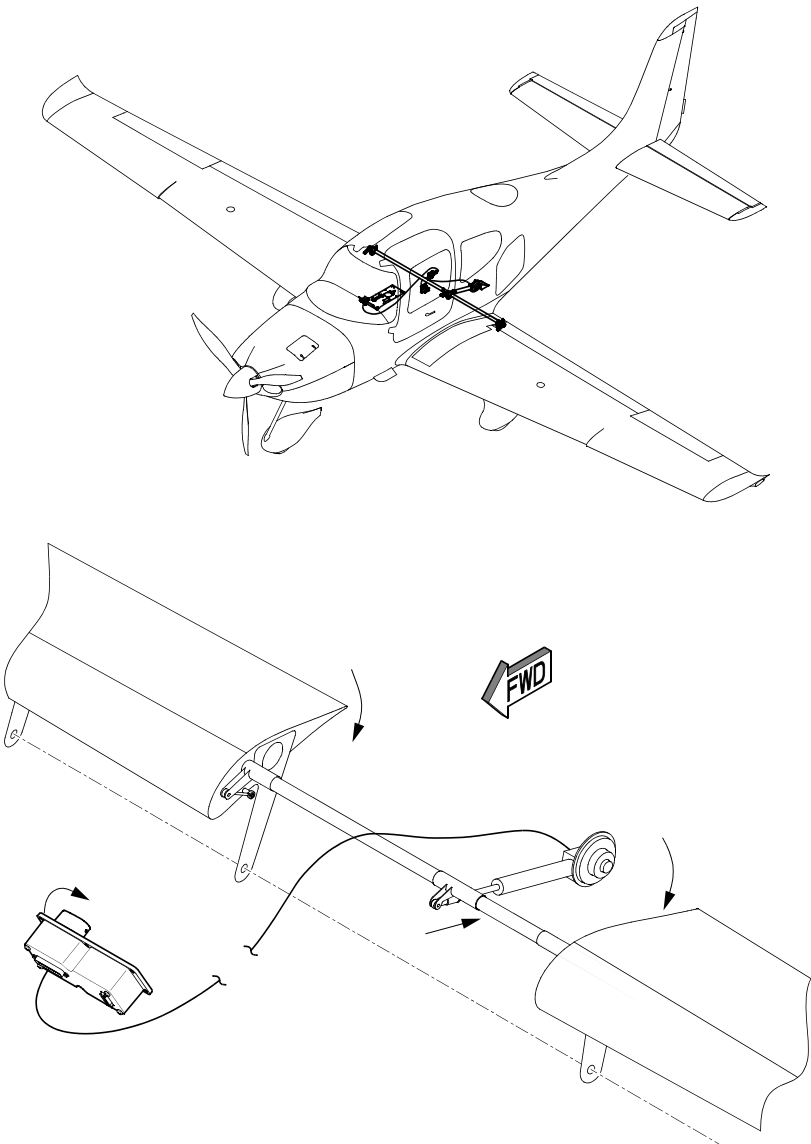

SR22\_FM07\_2935A

**Figure 7-6**  
**Wing Flaps**

# Landing Gear

## Main Gear

The main landing gear are bolted to composite wing structure between the wing spar and shear web. The landing gear struts are constructed of composite material for fatigue resistance. The composite construction is both rugged and maintenance free. The main wheels and wheel pants are bolted to the struts.

Each main gear wheel has a 15 x 6.00 x 6 tire with an inner-tube installed (*Serials 0442 thru 0656, 0658 thru 0689 before SB2X-32-21*), or with a tubeless tire installed (*0442 thru 0656, 0658 thru 0689 after SB2X-32-21, 0657, 0690 & subs*).

Standard wheel pants are easily removable to provide access to tires and brakes. Access plugs in the wheel pants can be removed to allow tire inflation and pressure checking. Each main gear wheel is equipped with an independent, hydraulically operated single cylinder, dual piston, disc brake.

## Nose Gear

The nose gear strut is of tubular steel construction and is attached to the steel engine mount structure. Shock absorption is accomplished by an oleo shock absorber. **The nosewheel is free casting and can turn through an arc of approximately 170 degrees (85 degrees degrees either side of center)**. Steering is accomplished by differential application of individual main gear brakes.

Each nosewheel has a 5.00 x 5 tire with an inner-tube installed (*Serials 0442 thru 0656, 0658 thru 0689 before SB2X-32-21*), or with a tubeless tire installed (*Serials 0442 thru 0656, 0658 thru 0689 after SB2X-32-21, 0657, 0690 & subs*).

## Brake System

**The main wheels have hydraulically operated, single-disc type brakes**, individually activated by floor mounted toe pedals at both pilot stations. A parking brake mechanism holds induced hydraulic pressure on the disc brakes for parking. The brake system consists of a master cylinder for each rudder pedal, a hydraulic fluid reservoir, a parking brake valve, a single disc brake assembly on each main landing gear wheel, temperature sensors, and associated hydraulic plumbing and wiring.

Braking pressure is initiated by depressing the top half of a rudder pedal (toe brake). The brakes are plumbed so that depressing either the pilot's or copilot's left or right toe brake will apply the respective (left or right) main wheel brake.

The reservoir is serviced with MIL-H-5606 hydraulic fluid (*Serials 0442 thru 0656, 0658 thru 0689 before SB2X-32-21*), or MIL-PRF-87257 hydraulic fluid (*Serials 0442 thru 0656, 0658 thru 0689 after SB2X-32-21, 0657, 0690 & subs*).

Brake system malfunction or impending brake failure may be indicated by a gradual decrease in braking action after brake application, noisy or dragging brakes, soft or spongy pedals, excessive travel, and/or weak braking action. A temperature sensor is mounted to each brake assembly and provides measured brake temperatures to the avionics system for caution and warning annunciation.

Should any of these symptoms occur, immediate maintenance is required. If, during taxi or landing roll, braking action decreases, let up on the toe brakes and then reapply the brakes with heavy pressure. If the brakes are spongy or pedal travel increases, pumping the pedals may build braking pressure.

Refer to Section 10, *Taxiing, Steering, and Braking Practices* for Brake System operational considerations.

### **Parking Brake**

#### **• Caution •**

Do not set the PARK BRAKE in flight. If a landing is made with the parking brake valve set, the brakes will maintain any pressure applied after touchdown.

The main wheel brakes are set for parking by using the PARK BRAKE handle on the right side kick plate near the pilot's right knee. Brake lines from the toe brakes to the main wheel brake calipers are plumbed through a parking brake valve. For normal operation, the handle is pushed in. With the handle pushed in, poppets in the valve are mechanically held open allowing normal brake operation. When the handle is pulled out, the parking brake valve holds applied brake pressure, locking the brakes. To apply the parking brake, set the brakes with the rudder-pedal toe brakes, and then pull the PARK BRAKE handle aft.

## Baggage Compartment

The baggage compartment, located on the left side of the fuselage aft of the wing, allows entry to the baggage compartment. The baggage door is hinged on the forward edge and latched on the rear edge. The door is locked from the outside with a key lock. The baggage compartment key will also open the cabin doors.

The baggage compartment extends from behind the rear passenger seat to the aft cabin bulkhead. The rear seats can be folded forward to provide additional baggage area for long or bulky items.

### Baggage Tie-Downs/Cargo Net

• Caution •

If not adequately restrained, baggage compartment items may pose a projectile hazard to cabin occupants in the event of rapid deceleration. Secure all baggage items with tie-down straps or cargo net.

Four baggage tie-down straps are provided to secure items in the baggage compartment. Each strap assembly has a hook at each end and a cam-lock buckle in the middle. The hook ends clip over loop fittings installed in the baggage floor and in the rear bulkhead. The tie-down straps should be stowed attached and tightened to the fittings.

The aircraft is equipped with a retractable cargo net to secure items in the baggage compartment. Integral inertia reels attached to the rear bulkhead allow the cargo net to be extended forward, placed over baggage, and secured to the seat back via four latch assemblies. The cargo net should be stowed attached to the seat back fittings.

The cargo net is not functional when rear seats are folded forward. Use conventional tie-down straps in this configuration.

For baggage area and door dimensions see Section 1, [Airplane Interior Dimensions](#).

## Seats

The seating arrangement consists of two individually adjustable seats for the pilot and front seat passenger and a “2+1” configuration with a one-piece bench seat and fold-down seat backs for the rear seat passengers.

### • Caution •

Do not kneel or stand on the seats. The seat bottoms have an integral aluminum honeycomb core designed to crush under impact to absorb downward loads.

## Front Seats

The front seats are adjustable fore and aft and the seat backs can be reclined for passenger comfort or folded forward for rear seat access. Integral headrests are provided. The fore and aft travel path is adjusted through the seat position control located below the forward edge of the seat cushion. The seat track is angled upward for forward travel so that shorter people will be positioned slightly higher as they adjust the seat forward. Recline position is controlled through levers located on each side of the seat backs. Depressing the recline release control while there is no pressure on the seat back will return the seat back to the full up position.

To position front seat fore and aft:

1. Lift the position control handle.
2. Slide the seat into position.
3. Release the handle and check that the seat is locked in place.

To adjust recline position:

1. Actuate and hold the seat back control lever.
2. Position the seat back to the desired angle.
3. Release the control lever.

## Rear Seats

The rear seats employ a one-piece bench seat and two seat backs configured in 60/40 split. This “2+1” seating configuration provides for a center seat/restraint area for a third passenger on the wider left hand seat.

Each seat back reclines independently of each other and can be folded forward to provide a semi-flat surface for cargo extending



forward from the baggage compartment. Recline position is controlled through a lever located on either side of the seat.

To fold seat back forward:

1. With no pressure on the seat back, rotate the lever to the recline position and fold the seat back forward.

## **Seat Belt and Shoulder Harness**

Integrated seat belt and shoulder harness assemblies with inertia reels are provided for the pilot and each passenger.

The front seats use a 4-point inflatable restraint system. Forward seat belts are attached to the seat frame. The shoulder harnesses are attached to inertia reels mounted in the seat back.

The rear seats use a 3-point safety harness consisting of one shoulder harness and a lap belt. The rear seat belts are attached to fittings on the cabin floor. The shoulder harnesses are attached to inertia reels mounted to the baggage compartment rear bulkhead.

Each front and rear seat shoulder harness is attached to the seat belt. The inertia reels allow complete freedom of movement of the occupant's upper torso. In the event of a sudden deceleration, the reels lock automatically to protect the occupants. It is recommended that the seat belts be stowed in the latched position when not in use.

### **Front Seat Inflatable Restraints**

An inflatable shoulder harness is integral to each front seat harness. The electronic module assembly, mounted below the cabin floor, contains a crash sensor, battery, and related circuitry to monitor the deceleration rate of the airplane. In the event of a crash, the sensor evaluates the crash pulse and sends a signal to an inflator assembly mounted to the aft seat frame. This signal releases the gas in the inflator and rapidly inflates the airbag within the shoulder harness cover. After airbag deployment, the airbag deflates to enable the pilot/co-pilot to egress the airplane without obstruction.

The crash sensor's predetermined deployment threshold does not allow inadvertent deployment during normal operations, such as hard landings, strikes on the seat, or random vibration.

#### **• Caution •**

No slack may exist between the occupant's shoulder and restraint harness shoulder strap.

**Stow the seat belts in the latched position when not in use.**

To use the restraints:

1. Slip arms behind the harness so that the harness extends over shoulders.
2. Hold the buckle and firmly insert the link.
3. Grasp the seat belt tabs outboard of the link and buckle and pull to tighten. Buckle should be centered over hips for maximum comfort and safety.
4. Restraint harnesses should fit snug against the shoulder with the lap buckle centered and tightened around the hips.

To release the restraints:

1. Grasp the top of the buckle opposite the link and pull outward. The link will slip free of buckle.
2. Slip arms from behind the harness.

### **Child Restraint System**

The aircraft is equipped with provisions for installing two LATCH compliant child seats in the outboard rear seat positions, OR one non-LATCH compliant seat in the center rear seat position.

Lower anchors for the LATCH compliant seats are located in the outboard seat positions. The non-LATCH compliant seat must be

installed using the center seat belt. Three top tether anchors for the child seats are located on the rear bulkhead.

To install a child seat:

1. Fasten lower seat attachments to bench seat:
  - a. *LATCH Compliant Outboard Seat*: Fasten lower seat attachment to the outboard anchors in the bench seat.
  - b. *Non-LATCH Complaint Center Seat*: Using the center seat belt, fasten lower seat attachments to the bench seat as described by the manufacturer's instructions
2. Locate top tether pass-through - a narrow slit in the seat back upholstery - near the top, outboard section of the seat back.

• **Caution** •

Do not route child seat top tether over or around seat back. The top tether must be routed through the seat back pass-through for the child seat to function properly.

3. Route child seat's top tether through the seat back pass-through.
4. Fasten top tether to rear bulkhead anchor.  
Firmly tension the child seat straps according to the manufacturer's instructions.

## Cabin Doors

Two large forward hinged doors allow crew and passengers to enter and exit the cabin. The door handles engage striker pins in the door frame receptacles at the upper aft and lower aft door perimeter. Gas charged struts provide assistance in opening the doors and hold the doors open against gusts. Front seat armrests are integrated with the doors. A key lock in each door provides security. The cabin door keys also fit the baggage compartment door lock. Separate keys are provided for the fuel caps.

### Key Fob

*Serials 1233 & subs w/ Convenience Lighting:*

Remote operation of the door locks is provided by a battery-powered key fob.

This device complies with part 15 of the FCC Rules. Operation is subject to the following two conditions:

1. This device may not cause harmful interference.
2. This device must accept any interference received, including interference that may cause undesired operation.

• Note •

Key fob will not actuate door locks when BAT 1 switch is ON.

### Windshield and Windows

The windshield and side windows are manufactured of acrylic. Use only clean soft cloths and mild detergent to clean acrylic surfaces. Refer to Section 8, [Windshield and Windows](#) for detailed cleaning instructions.

## Engine

The airplane is powered by a Teledyne Continental TSIO-550-K, twin turbocharged, direct drive, fuel injected, air cooled, horizontally opposed 6 cylinder engine that uses a high pressure, wet sump style oil system for lubrication. The engine has a 550 cubic inch displacement and is rated to 315 bhp at 2500 RPM with a 2000-hour Time Between Overhaul (TBO) schedule. The engine utilizes a top air induction system, engine mounted throttle body, bottom exhaust system, and a full flow spin-on disposable oil filter. Engine front accessories include a hydraulically operated propeller governor, a gear-driven primary alternator and a belt-driven secondary alternator. Rear engine accessories include a starter, gear driven oil pump, gear driven fuel pump, and dual gear driven magnetos. The engine is attached to the firewall by a six-point steel engine mount. The firewall attach points are structurally reinforced with gusset-type attachments that transfer thrust and bending loads into the fuselage shell.

### Engine Controls

Engine controls are easily accessible to the pilot on a center console. They consist of a single-lever power (throttle) control and a mixture control lever. A friction control wheel, labeled FRICTION, on the right side of the console is used to adjust control lever resistance to rotation for feel and control setting stability.

#### ***Power (Throttle) Lever***

The single-lever throttle control, labeled MAX-POWER-IDLE, on the console adjusts the engine throttle setting. The lever is mechanically linked by cable to the air throttle body/fuel-metering valve. Moving the lever towards MAX opens the air throttle butterfly and meters more fuel to the fuel manifold. No propeller control is required. The governor is set to 2500 maximum RPM in climb and cruise.

#### ***Mixture Control***

The mixture control lever, labeled RICH-MIXTURE-CUTOFF, on the console adjusts the proportion of fuel to air for combustion. The Mixture Control Lever is mechanically linked to the mixture control valve in the engine-driven fuel pump. Moving the lever forward (towards RICH) repositions the valve allowing greater proportions of fuel and moving the lever aft (towards CUTOFF) reduces (leans) the proportion of fuel. Full aft position (CUTOFF) closes the control valve.

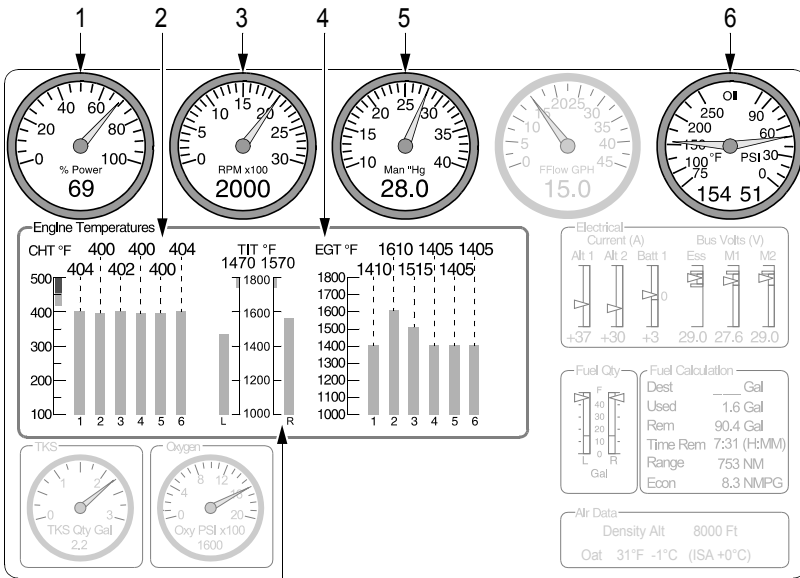

7 Engine Instruments

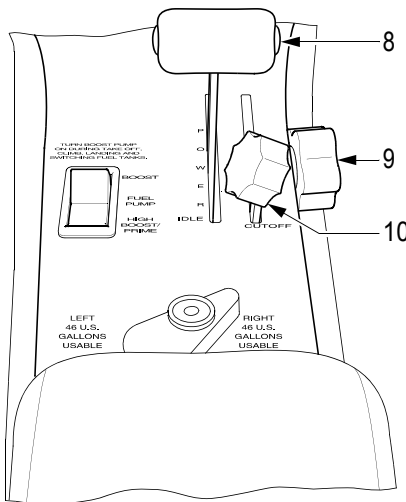

- LEGEND**
1. Percent Power
  2. CHT
  3. Tachometer
  4. EGT
  5. Manifold Pressure
  6. Oil Temperature and Pressure
  7. Turbine Inlet Temperature
  8. Power Lever
  9. Friction Control
  10. Mixture Control

Engine Controls

SR22\_FM07\_3255A

**Figure 7-7  
Engine Controls and Indicating**

## Engine Indicating

Engine information is displayed as analog-style gages, bar graphs, and text on the MFD's ENGINE page. When the ENGINE page is not active or in the case of an electronic display failure (backup mode), all essential engine information is displayed along the LH edge of the display. Engine data is acquired by the Engine Airframe Unit which transmits the data to the Engine Indicating System for display as described in the following pages.

• Note •

A "Red X" through any electronic display field indicates that the display field is not receiving valid data and should be considered inoperative.

### ***Engine System Annunciations***

Engine system health, caution, and warning messages are displayed in color-coded text in the Crew Alerting System (CAS) window located to the right of the Altimeter and Vertical Speed Indicator. In combination with a CAS alert, the affected engine parameter displayed on the ENGINE page changes to the corresponding color of CAS alert and the annunciation system issues an audio alert.

For specific pilot actions in response to Engine System Annunciations, refer to Section 3 - Emergency Procedures, [Engine System Emergencies](#), and Section 3A - Abnormal Procedures, [Engine System](#).

For additional information on Engine Instrument Markings and Annunciations, refer to [Section 2: Limitations](#).

For additional information on the System Annunciations And Alerts, refer to the [Perspective Integrated Avionics System](#) description in this section.

### ***Tachometer***

Engine speed (RPM) is shown in the upper mid-left corner of the ENGINE page as both a simulated tachometer and as a digital value. The tachometer pointer sweeps a scale range from 0 to 3000 RPM in 100 RPM increments. The digital RPM value is displayed in increments of 10 RPM in white numerals below the gage.

The tachometer receives a speed signal from a magnetic pickup sensor on the right hand magneto from the Engine Indicating System via the Engine Airframe Unit.

### ***Exhaust Gas Temperature (EGT)***

Exhaust gas temperatures for all six cylinders are displayed in the Engine Temperature block of the ENGINE page as vertical bars. The EGT graph is marked from 1000°F to 1800°F in 100°F increments. The digital EGT value of the cylinder is displayed above the bar in white numerals. A sensor in the exhaust pipe of each cylinder measures exhaust gas temperature and provides a voltage signal to the Engine Airframe Unit which processes and transmits the data to the Engine Indicating System.

### ***Cylinder Head Temperature (CHT)***

Cylinder head temperatures for all six cylinders are displayed in the Engine Temperature block of the ENGINE page as vertical bars. The CHT graph is marked from 100°F to 500°F in 100°F increments. The digital CHT value of the cylinder is displayed above the bar in white numerals.

A sensor in each cylinder head measures cylinder head temperature and provides a voltage signal to the Engine Airframe Unit which processes and transmits the data to the Engine Indicating System.

### ***Turbine Inlet Temperature (TIT)***

Turbine inlet temperature for the LH and RH turbochargers is displayed in the Engine Temperature block of the ENGINE page as vertical bars. The TIT graph is marked from 1000°F to 1800°F in 100°F increments. The digital TIT value of the turbine inlet is displayed above the bar in white numerals.

A sensor in each turbocharger measures turbine inlet temperature and provides a voltage signal to the Engine Airframe Unit which processes and transmits the data to the Engine Indicating System. The TIT gage is used as the primary source to lean fuel mixture.



### ***Oil Temperature***

Oil temperature is shown in the upper right corner of the ENGINE page, opposite the oil pressure scale, as both a simulated temperature gage and as a digital value. The gage pointer sweeps a scale range from 75°F to 250°F in 50°F increments. The digital temperature value is displayed in white numerals below the gage.

The oil temperature sensor is mounted below the oil cooler and provides a signal to the Engine Airframe Unit that is processed and transmitted to the Engine Indicating System for display.

### ***Oil Pressure***

Oil Pressure is shown in the upper right corner of the ENGINE page, opposite the oil temperature scale, as both a simulated pressure gage and as a digital value. The gage pointer sweeps a scale range from 0 to 90 PSI in 10 PSI increments. The digital pressure value is displayed in white numerals below the gage.

The oil pressure sensor is mounted below the oil cooler and provides a signal to the Engine Airframe Unit that is processed and transmitted to the Engine Indicating System for display.

### ***Manifold Pressure Gage***

Manifold pressure is shown in the upper center portion of the ENGINE page as both a simulated pressure gage and as a digital value. The gage pointer sweeps a scale range from 10 to 40 inches of mercury in 1 in.Hg increments. The digital MAP value is displayed in white numerals below the gage. The manifold pressure sensor is mounted in the induction air manifold near the throttle body and provides a signal to the Engine Airframe Unit that is processed and transmitted to the Engine Indicating System for display.

### ***Percent Power Gage***

Percent power is shown in the upper left corner of the ENGINE page as both a simulated gage and as a digital value. The percent power gage sweeps a scale marked from 0 to 100 percent in 5 percent increments. The digital percent power value is displayed in white numerals below the gage. The display units calculate the percentage of maximum engine power produced by the engine based on an algorithm employing manifold pressure, indicated air speed, outside air temperature, pressure altitude, engine speed, and fuel flow.

## Engine Lubrication System

The engine is provided with a wet-sump, high-pressure oil system for engine lubrication and cooling. Oil for engine lubrication is drawn from an eight-quart capacity sump through an oil suction strainer screen and directed through the oil filter to the engine-mounted oil cooler by a positive displacement oil pump. The oil pump is equipped with a pressure relief valve at the pump output end to bypass oil back to the pump inlet should the pump exceed limits. The oil cooler is equipped with a temperature control valve set to bypass oil if the temperature is below approximately 180°F (82°C). Bypass or cooled oil is then directed through oil galleries to the engine rotating parts and piston inner domes. Oil is also directed to the propeller governor to regulate propeller pitch. The complete oil system is contained in the engine. An oil filler cap and dipstick are located at the left rear of the engine. The filler cap and dipstick are accessed through a door on the top left side of the engine cowling.

## Ignition and Starter System

Two engine-driven magnetos and two spark plugs in each cylinder provide engine fuel ignition. The right magneto fires the lower right and upper left spark plugs, and the left magneto fires the lower left and upper right spark plugs. Normal operation is conducted with both magnetos, as more complete burning of the fuel-air mixture occurs with dual ignition. A rotary-type key switch, located on the instrument panel, controls ignition and starter operation. The switch is labeled OFF-R-L- BOTH-START. In the OFF position, the starter is electrically isolated, the magnetos are grounded and will not operate. Normally, the engine is operated on both magnetos (switch in BOTH position) except for magneto checks and emergency operations. The R and L positions are used for individual magneto checks and for single magneto operation when required. When the battery master switch is ON, rotating the switch to the spring loaded START position energizes the starter and activates both magnetos. The switch automatically returns to the BOTH position when released.

28 VDC for Starter operation is supplied through the 2-amp STARTER circuit breaker on NON-ESSENTIAL BUS.

## Air Induction System

Induction air enters the engine compartment through two NACA ducts located in the lower engine cowls. The air continues to the air boxes where it is filtered and ducted into the compressor housing where the compressor wheel, spinning at a high RPM, increases the air pressure which provides a greater mass of air available to the engine for the combustion cycle. From the compressor housing, the air is ducted through the intercoolers where the air temperature is lowered which further increases the density of the induction air. Downstream of the intercoolers the airflow joins at the "Y" junction of intake tubes, then passes through the throttle body and into the intake manifold where it is divided by the intake pipes flowing to each cylinder.

In the case of filter blockage or induction ice, alternate air can enter the engine via the alternate air assembly located in the lower front of the engine and connected to the LH and RH air boxes. Under normal conditions, the alternate air assembly door is held closed by magnetic force. If the air induction system should become blocked, suction created by the engine will open the door and draw unfiltered air from inside the cowl. When the door opens, a switch opens which causes an annunciation on the Primary Flight Display to alert the pilot.

Use of alternate air will result in a reduction of engine power due to lower inlet air pressure and higher air temperature. Additionally loss of manifold pressure will occur when operating at high altitude and low RPM where the turbocharger wastegate is closed.

## Engine Exhaust System

After leaving the cylinders, exhaust gases flow through the exhaust collector to the turbocharger turbine housing inlet. The exhaust gas flow provides turbine wheel rotation then exits through the turbine housing discharge port and overboard through tailpipes exiting through the lower cowling.

## Engine Fuel Injection

The multi-nozzle, continuous-flow fuel injection system supplies fuel for engine operation. An engine driven fuel pump draws fuel from the selected wing tank and passes it to the mixture control valve integral to the pump. The mixture control valve proportions fuel in response to the pilot operated mixture control lever position. From the mixture control, fuel is routed to the fuel-metering valve on the air-induction system throttle body. The fuel-metering valve adjusts fuel flow in

response to the pilot controlled Power Lever position. From the metering valve, fuel is directed to the fuel manifold valve (spider) and then to the individual injector nozzles. The system meters fuel flow in proportion to engine RPM, mixture setting, and throttle angle. Manual mixture control and idle cut-off are provided. An electric fuel pump provides fuel boost for vapor suppression and for priming.

## Engine Cooling

Engine cooling is accomplished by discharging heat to the oil and then to the air passing through the oil cooler, and by discharging heat directly to the air flowing past the engine. **Cooling air enters the engine compartment through the two inlets in the cowling.** Aluminum baffles direct the incoming air to the engine and over the engine cylinder cooling fins where the heat transfer takes place. The heated air exits the engine compartment through louvered vents in the bottom of the cowlings. No movable cowl flaps are used.

## Turbochargers

The TSIO-550-K has **twin turbochargers** which use exhaust gas flow to boost induction air pressure for increased power. There is one turbocharger on each side of the engine. The turbochargers compress and raise the temperature of the incoming air before going to the intercoolers. The dual turbochargers are lubricated from external oil supply lines from a source at the bottom of the oil cooler. **There is one oil pressure actuated wastegate on the left side of the engine controlling the amount of exhaust gas used by the turbochargers.** Control is accomplished by a diaphragm actuated valve sensing differential pressure across the throttle plate and controlling the oil return flow rate from the wastegate. An overboost valve in the induction system provides protection from too much pressure by actuating at overly high manifold pressures.

## Propeller

The airplane is equipped with a composite, three-blade, constant speed, governor-regulated propeller.

The propeller governor automatically adjusts propeller pitch to regulate propeller and engine RPM by controlling the flow of engine oil - boosted to high pressure by the governing pump - to or from a piston in the propeller hub. Oil pressure acting on the piston twists the blades toward high pitch (low RPM). When oil pressure to the piston in the propeller hub is relieved, centrifugal force, assisted by an internal spring, twists the blades toward low pitch (high RPM). Any change in airspeed or load on the propeller results in a change in propeller pitch. During climb and cruise, the governor automatically adjusts propeller pitch in order to maintain a 2500 RPM setting.

## Fuel System

An 92-gallon usable wet-wing fuel storage system provides fuel for engine operation. The system consists of a 47.25-gallon capacity (46-gallon usable) vented integral fuel tank and a fuel collector/sump in each wing, a three position selector valve, an electric fuel pump, and an engine-driven fuel pump. Fuel is gravity fed from each tank to the associated collector sumps where the engine-driven fuel pump draws fuel through a filter and selector valve to pressure feed the engine fuel injection system. The electric fuel pump is provided for engine priming and vapor suppression.

Each integral wing fuel tank has a filler cap in the upper surface of each wing for fuel servicing. Access panels in the lower surface of each wing allow access to the associated wet compartment (tank) for inspection and maintenance. Float-type fuel quantity sensors in each wing tank supply fuel level information to the fuel quantity gages. Positive pressure in the tank is maintained through a vent line from each wing tank. Fuel, from each wing tank, gravity feeds through strainers and a flapper valve to the associated collector tank in each wing. Each collector tank/sump incorporates a flush mounted fuel drain and a vent to the associated fuel tank.

The engine-driven fuel pump pulls filtered fuel from the two collector tanks through a three-position (LEFT-RIGHT-OFF) selector valve. The selector valve allows tank selection. From the fuel pump, the fuel is metered to a flow divider, and delivered to the individual cylinders. Excess fuel is returned to the selected tank.

A simulated fuel quantity gage is located on the Engine Strip along the left edge of the MFD and in the Fuel Qty block on the MFD's Engine page.

Fuel shutoff and tank selection is positioned nearby for easy access. Fuel system venting is essential to system operation. Blockage of the system will result in decreasing fuel flow and eventual engine fuel starvation and stoppage. Venting is accomplished independently from each tank by a vent line leading to a NACA-type vent mounted in an access panel underneath the wing near each wing tip.

The airplane may be serviced to a reduced capacity to permit heavier cabin loadings. This is accomplished by filling each tank to a tab visible below the fuel filler, giving a reduced fuel load of 30.0 gallons usable in each tank (60 gallons total usable in all flight conditions).

Drain valves at the system low points allow draining the system for maintenance and for examination of fuel in the system for contamination and grade. The fuel must be sampled prior to each flight. A sampler cup is provided to drain a small amount of fuel from the wing tank drains, the collector tank drains, and the gascolator drain. **If takeoff weight limitations for the next flight permit, the fuel tanks should be filled after each flight to prevent condensation.**

## Fuel Selector Valve

A fuel selector valve, located at the rear of the center console, provides the following functions:

- LEFT Allows fuel to flow from the left tank
- RIGHT Allows fuel to flow from the right tank
- OFF Cuts off fuel flow from both tanks

The valve is arranged so that to feed off a particular tank the valve should be pointed to the fuel indicator for that tank. To select RIGHT or LEFT, rotate the selector to the desired position. To select Off, first raise the fuel selector knob release and then rotate the knob to OFF.

## Fuel Pump Operation

Fuel pump operation and engine prime is controlled through the Fuel Pump rocker switch located adjacent to the fuel selector valve.

**To prevent over-priming, the system uses a lockout relay that only allows HIGH BOOST/PRIME for engine start and operations at high power settings.** When the manifold pressure is less than 24 in-Hg and engine RPM is greater than 500 RPM, pressing the HIGH BOOST/PRIME limits the fuel pump to low-speed mode BOOST.

**Selecting BOOST energizes the fuel pump in low-speed mode regardless of engine speed or manifold pressure to deliver a continuous 4-6 psi boost to the fuel flow for vapor suppression in a hot fuel condition.**

The fuel pump operates on 28 VDC supplied through the 5-amp FUEL PUMP circuit breaker on MAIN BUS 2.

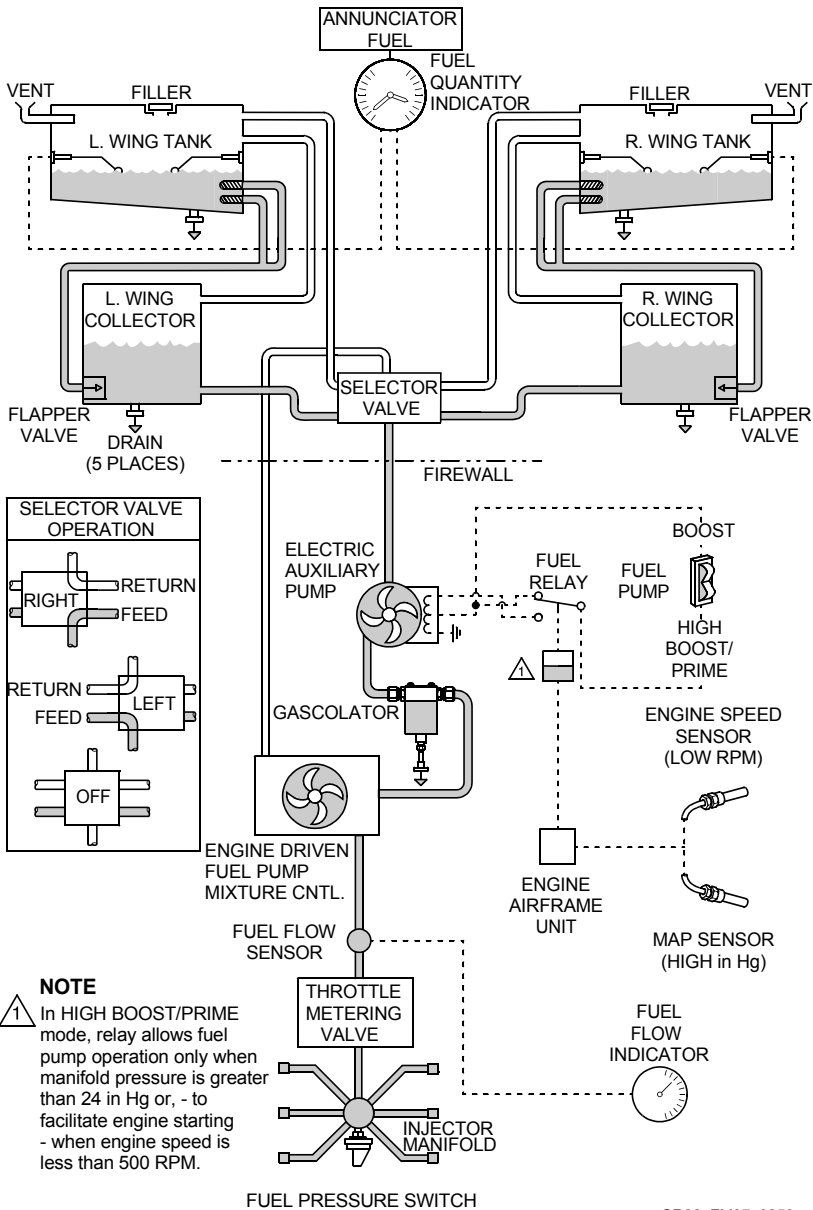

SR22\_FM07\_3259

**Figure 7-8**  
**Fuel System Schematic**



## Fuel Indicating

Fuel quantity is measured by float-type quantity sensors installed in each fuel tank and displayed on the Fuel Quantity Gage.

- **Caution** •

When the fuel tanks are 1/4 full or less, prolonged uncoordinated flight such as slips or skids can uncover the fuel tank outlets. Therefore, if operating with one fuel tank dry or if operating on LEFT or RIGHT tank when 1/4 full or less, do not allow the airplane to remain in uncoordinated flight for periods in excess of 30 seconds.

- Note •

A “Red X” through any electronic display field indicates that the display field is not receiving valid data and should be considered inoperative.

### ***Fuel Quantity Gage***

A dual reading fuel quantity gage is displayed on the Engine Strip along the left edge of the MFD and in the Fuel Qty block of the ENGINE page. In the case of an electronic display failure (backup mode), all essential fuel information is displayed on the Engine Strip along the left edge of the PFD. The LEFT pointer indicates left tank fuel quantity and sweeps a vertical bar scale marked from 0 to 46 U.S. gallons in 5-gallon increments. The RIGHT pointer sweeps an identical scale for the right tank. Each scale is marked with a yellow band from 0 to 14 U.S. gallons and a green band from 14 to 46 U.S. gallons. The indicators are calibrated to read 0 gallons when no usable fuel remains.

Fuel quantity is measured by a float type quantity sensors installed in the fuel tanks. Fluid quantity information is sent to the Engine Airframe Unit, processed, and transmitted to the simulated Fuel Quantity Gage and CAS window for display.

### ***Fuel Flow***

Fuel Flow is shown in the upper mid right corner of the ENGINE page as both a simulated gage and as a digital value. The gage pointer sweeps a scale range from 0 to 45 Gallons Per Hour (GPH). The fuel flow value is displayed in white numerals below the gage. Fuel flow is measured by a transducer on the right side of the engine in the fuel line between the engine driven fuel pump and distribution block. The

fuel flow signal is sent to the Engine Airframe Unit, processed, and transmitted to the Engine Indicating System for display.

The gage displays a green normal arc, which is dynamically updated to display the range of normal values appropriate to engine power settings.

- When manifold pressures is above 30.6 in.Hg, the green arc covers a narrow range depicting the full rich fuel flow appropriate for that power setting.
- For manifold pressures of 30.5 in.Hg and below, the normal arc extends from full rich limit to 10 gallons per hour (indicating that cruise leaning is permitted).

Target Fuel Flow is a cyan pointer placed on the fuel gage to indicate best economy target fuel flow. This pointer is displayed when cruise leaning is allowed (manifold pressure of 30.5 in.Hg or below), it will be presented after the green arc expands when power is reduced. This indicator provides guidance to aide in cruise leaning, it is calculated to provide a fuel flow closely corresponding with the best economy fuel to air ratio.

• Note •

Target Fuel Flow is removed from gage when resulting engine power would be less than 55% (intended for cruise, not descent leaning guidance).

### ***Fuel Totalizer and Calculated Information***

Fuel totalizer calculations are located in the lower right section of the ENGINE page and are separate and independent of the fuel quantity gage and float sensor system. The fuel totalizer monitors fuel flow and calculates fuel-to-destination, fuel used, fuel remaining, time remaining, fuel range, and nautical miles per gallon. Upon system startup, the fuel totalizer initial fuel screen appears and prompts the user to enter the total fuel on board at start. The option to enter the number of gallons added since last fuel fill and the ability to set fuel to “Full” or to “Tabs” buttons is also available.

### ***Fuel System Annunciations***

Fuel system health, caution, and warning messages are displayed in color-coded text in the Crew Alerting System (CAS) window located to the right of the Altimeter and Vertical Speed Indicator. In combination with a CAS alert, the affected fuel parameter displayed on the

ENGINE page changes to the corresponding color of CAS alert and the annunciation system issues an audio alert.

**FUEL QTY:** Fuel quantity.

- A white Advisory message is generated when either fuel tank goes below 14 gallons.
- An amber Caution message is generated when both fuel tanks go below 14 gallons.
- A red Warning message is generated when the *fuel totalizer* amount goes below 9 gallons, or if the sensed fuel quantity (left plus right) is below 9 gallons.

**FUEL IMBALANCE:** Imbalanced between Left and Right Tanks.

- A white Advisory message is generated when the imbalance between tanks is greater than 8 gallons.
- An amber Caution message is generated when the imbalance between tanks is greater than 10 gallons.
- A red Warning message is generated when the imbalance between tanks is greater than 12 gallons.

• Note •

For specific pilot actions in response to Fuel System Annunciations, refer to Section 3 - Emergency Procedures, *Fuel System Emergencies*, and Section 3A - Abnormal Procedures, *Fuel System*.

For additional information on Engine Instrument Markings and Annunciations, refer to *Section 2: Limitations*.

For additional information on the System Annunciations And Alerts, refer to the *Perspective Integrated Avionics System* description in this section.

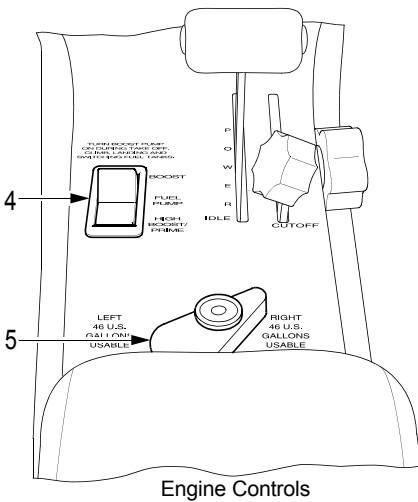
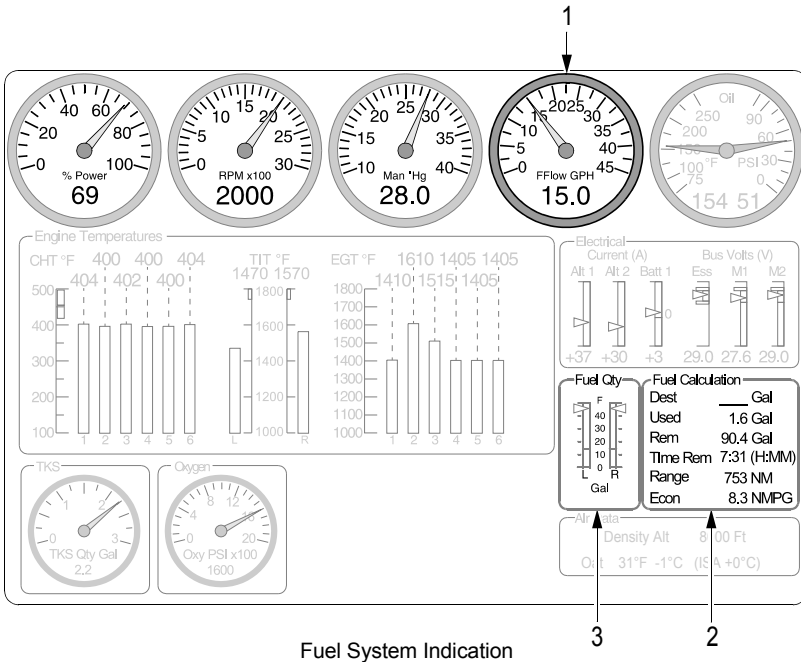

- LEGEND**
- Fuel Flow Gage
  - Fuel Calculations:
    - Fuel At Destination (Totalizer)
    - Fuel Used (Totalizer)
    - Fuel Remaining (Totalizer)
    - Time Remaining (Totalizer)
    - Fuel Range (Totalizer)
    - Nautical Miles Per Gallon (Totalizer)
  - Fuel Quantity Gage (Float Sensor)
  - Fuel Pump Switch
  - Fuel Selector Valve

SR22\_FM07\_3516

**Figure 7-9**  
**Fuel System Controls and Indicating**

## Electrical System

The airplane is equipped with a two-alternator, two-battery, 28-volt direct current (VDC) electrical system designed to reduce the risk of electrical system faults. The system provides uninterrupted power for avionics, flight instrumentation, lighting, and other electrically operated and controlled systems during normal operation.

### Power Generation

Primary power for the airplane is supplied by a 28-VDC, negative-ground electrical system. The electrical power generation system consists of two alternators controlled by a Master Control Unit (MCU) mounted on the left side of the firewall and two batteries for starting and electrical power storage.

Alternator 1 (ALT 1) is a gear-driven, internally rectified, 100-amp alternator mounted on the right front of the engine. Alternator 2 (ALT 2) is a belt-driven, internally rectified, 70-amp alternator mounted on the front left of the engine. ALT 1 is regulated to 28 volts and ALT 2 is regulated to 28.75 volts. Both alternators are self-exciting and require battery voltage for field excitation in order to start up - for this reason, the batteries should not be turned off in flight.

### Storage

Battery 1 (BAT 1) is an aviation grade 12-cell, lead-acid, 24-volt, 10-amp-hour battery mounted on the right firewall. BAT 1 is charged from the Main Distribution Bus 1 in the MCU.

Battery 2 (BAT 2) is composed of two 12-volt, 7-amp-hour, sealed, lead-acid batteries connected in series to provide 24 volts. Both BAT 2 units are located in a vented, acid-resistant container mounted behind the aft cabin bulkhead (FS 222) below the parachute canister. BAT 2 is charged from the circuit breaker panel ESS BUS 1.

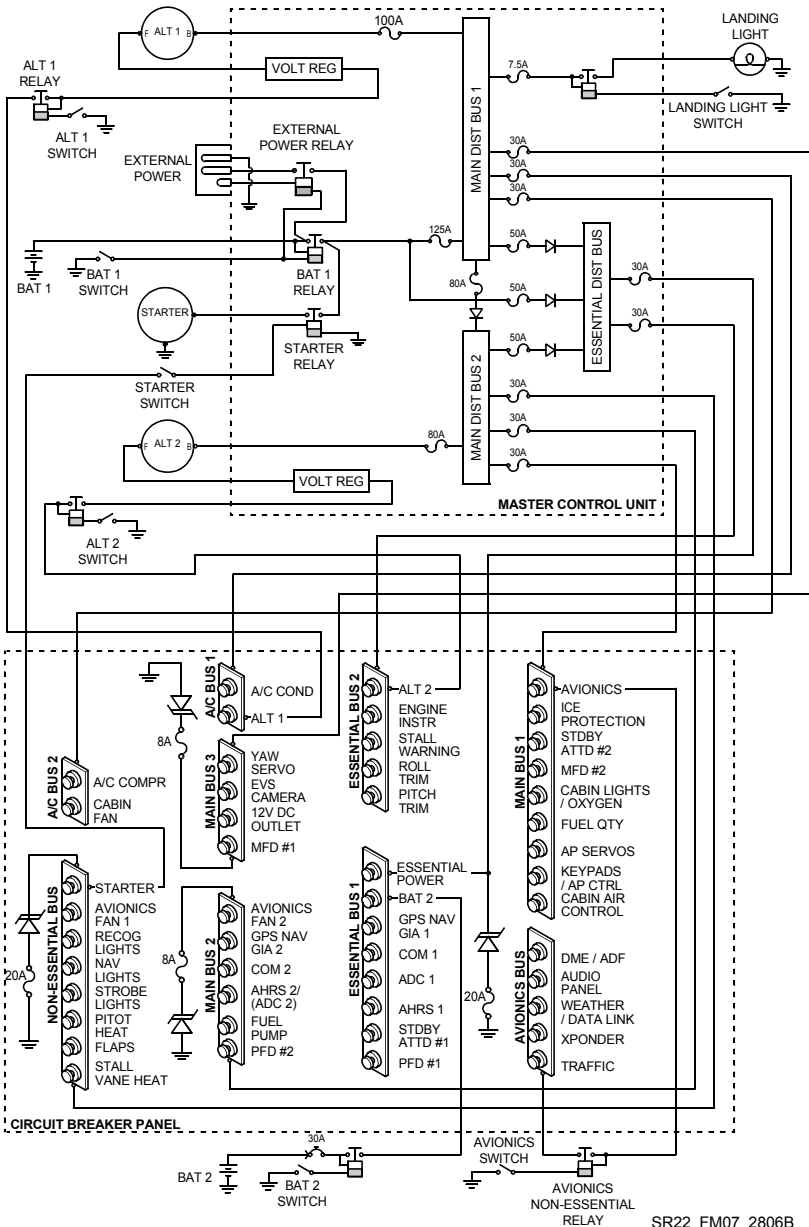

SR22\_FM07\_2806B

Figure 7-10

Electrical System Schematic - Serials 0442 thru 0656, 0658 thru 0689 (1 of 2)

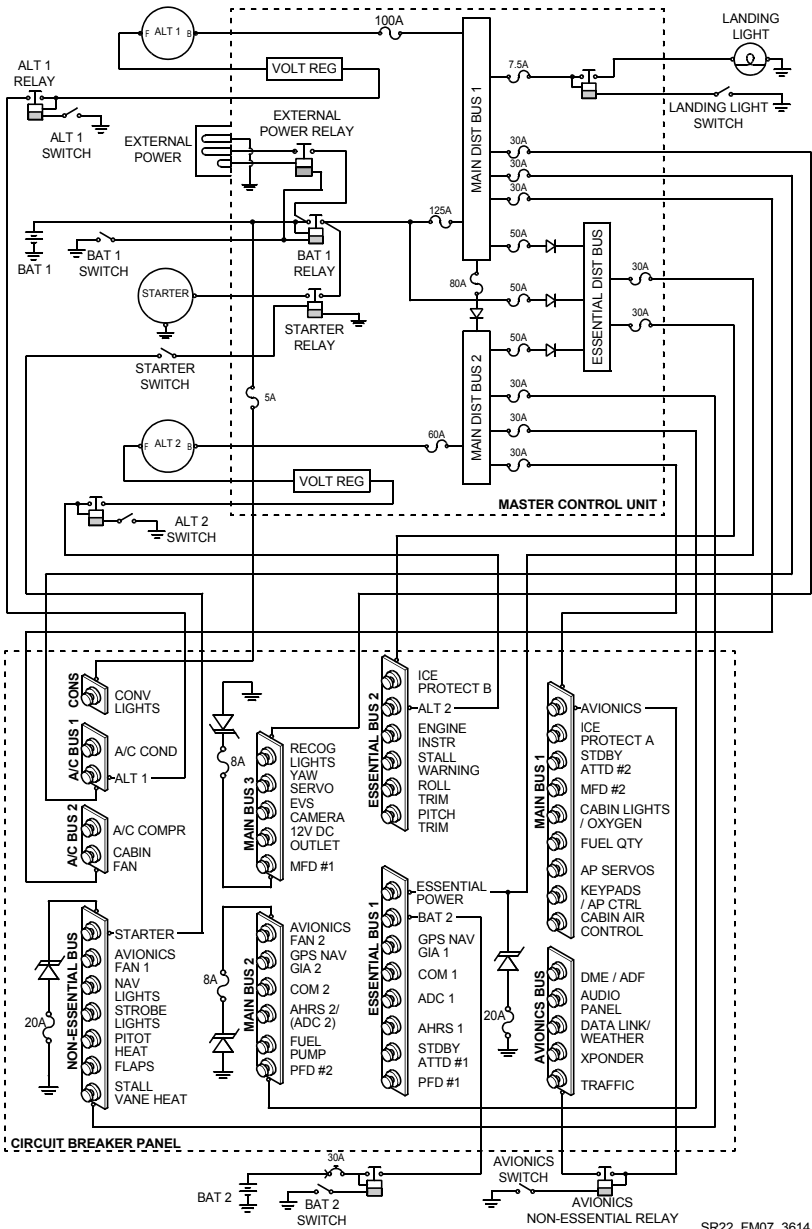

SR22\_FM07\_3614

**Figure 7-10**  
**Electrical System Schematic - Serials 0657, 0690 & subs (2 of 2)**

## Power Distribution

Power is supplied to the airplane circuits through three distribution buses contained in the MCU: Main Distribution Bus 1, Main Distribution Bus 2, and the Essential Distribution Bus. The three distribution buses power the associated buses on the circuit breaker panel.

### **Master Control Unit**

The Master Control Unit (MCU) is located on the left firewall. The MCU controls ALT 1, ALT 2, starter, landing light, external power, and power generation functions. In addition to ALT 1 and ALT 2 voltage regulation, the MCU also provides external power reverse polarity protection, alternator overvoltage protection, as well as electrical system health annunciations to the Integrated Avionics System. Power is distributed to the airplane circuit panel buses through Main and Essential buses in the MCU. The Main distribution buses are interconnected by an 80-amp fuse and a diode. The diode prevents ALT 2 from feeding the Main Distribution Bus 1. Additionally, since ALT 2 Bus voltage is slightly higher than ALT 1 voltage, bus separation is further assured.

### **Essential Distribution Bus**

The Essential Distribution Bus is fed by both Main Distribution Bus 1 and Main Distribution Bus 2 in the MCU through two 50-amp fuses. The Essential Bus powers two circuit breaker buses through 30-amp fuses located in the MCU:

- ESS BUS 1,
- ESS BUS 2.

### **Main Distribution Bus 1**

The output from ALT 1 is connected to the Main Distribution Bus 1 in the MCU through a 100-amp fuse. Main Distribution Bus 1 directly powers the Landing Light through a 7.5-amp fuse and three circuit breaker buses through 30-amp fuses located in the MCU:

- A/C BUS 1,
- A/C BUS 2,
- MAIN BUS 3.



## ***Main Distribution Bus 2***

The output from ALT 2 is connected to the Main Distribution Bus 2 in the MCU through an 80-amp fuse. Main Distribution Bus 2 powers three circuit breaker buses through 30-amp fuses located in the MCU:

- NON ESS BUS,
- MAIN BUS 1,
- MAIN BUS 2.

## ***Constant Power Bus - serials 0657, 0690 & subs***

The Constant Power Bus is fed by BAT 1 in the MCU through one 5-amp fuse located on top of the MCU.

## **Electrical System Protection**

### ***Circuit Breakers, Fuses and Voltage Suppressors***

Individual electrical circuits connected to the Main, Essential, and Non-Essential Buses in the airplane are protected by re-settable circuit breakers mounted in the circuit breaker panel on the left side of the center console. Loads on circuit breaker panel buses are shed by pulling the individual circuit breakers.

### ***Transient Voltage Suppressors***

Transient Voltage Suppressors (TVS) are installed in key areas of the electrical system to protect the system from lightning strikes. During lightning strikes, enormous energy spikes can be induced within the airplane electrical system. In the absence of any transient protection, this unwanted energy would typically be dissipated in the form of high-voltage discharge across the avionics and electrical systems of the airplane. By adding a high power TVS at key power entry points on the electrical busses, unwanted energy from electrical transients is allowed to dissipate through a semi-conducting pathway to ground.

#### **• Caution •**

If smoke and/or fumes are detected in the cabin and it is suspected that this event was caused by a TVS failure, the operator should confirm that there is no fire and perform the [Smoke and Fume Elimination](#) Checklist.

### ***Essential Buses***

The circuit breaker panel ESS BUS 1 and ESS BUS 2 are powered directly by ALT 1 and ALT 2 from the MCU Essential Distribution Bus

through 30-amp fuses inside the MCU and also by BAT 2 through the 20-amp BAT 2 circuit breaker.

In the event of ALT 1 or ALT 2 failure, the Essential Buses in the circuit breaker panel will be powered by the remaining alternator through the Main Distribution Bus 1 or Main Distribution Bus 2 in the MCU. In the case of both alternators failing, BAT 1 is connected directly to the Essential Distribution Bus in the MCU and will power ESS BUS 1 and ESS BUS 2. In the event of both alternators and BAT 1 failing, BAT 2 is connected directly to ESS BUS 1.

### ***Main Buses***

The circuit breaker panel MAIN BUS 1 and MAIN BUS 2 are powered by ALT 2 from the MCU Main Distribution Bus 2 and - in the event of ALT 2 failure - by ALT 1 and BAT 1 from the Main Distribution Bus 2 via the diode interconnecting the MCU distribution buses through 30-amp fuses inside the MCU.

The 10-amp AVIONICS circuit breaker on MAIN BUS 1, controlled through the AVIONICS master switch on the bolster switch panel, powers all loads on the AVIONICS BUS.

The circuit breaker panel MAIN BUS 3 is powered by ALT 1 and BAT 1 from the MCU Main Distribution Bus 1 through a 30-amp fuse inside the MCU. In the event of ALT 1 failure, BAT 1 will power MAIN BUS 3. ALT 2 is prevented from powering MAIN BUS 3 by the isolation diode interconnecting the MCU distribution buses 1 and 2.

### ***Non-Essential Buses***

The circuit breaker panel NON ESS BUS is powered by ALT 2 from the MCU Main Distribution Bus 2 and - in the event of ALT 2 failure - by ALT 1 and BAT 1 from the Main Distribution Bus 2 via the diode interconnecting the MCU distribution buses through 30-amp fuses inside the MCU. The Avionics Non-Essential Bus is powered through the 10-amp AVIONICS circuit breaker on MAIN BUS 1 and is discussed above.

The circuit breaker panel A/C BUS 1 and A/C BUS 2, is powered by ALT 1 and BAT 1 from the MCU Main Distribution Bus 1 through a 30-amp fuse inside the MCU. In the event of ALT 1 failure, BAT 1 will power A/C BUS 1 and A/C BUS 2. ALT 2 is prevented from powering A/C BUS 1 and A/C BUS 2 by the isolation diode interconnecting the MCU distribution buses 1 and 2.

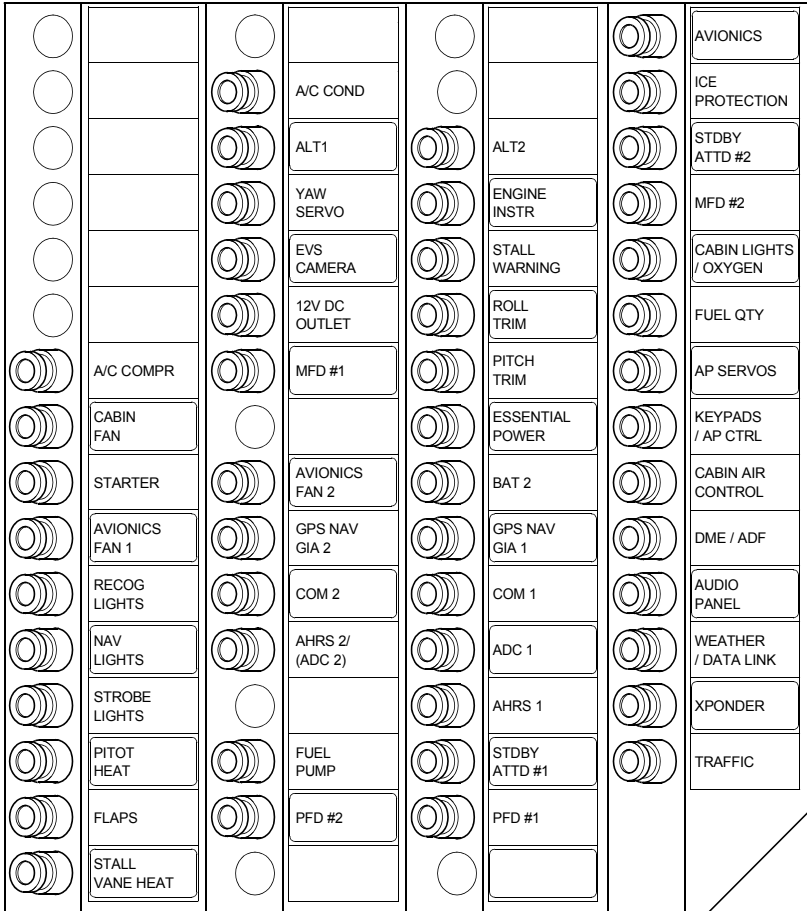

SR22\_FM07\_3519

**Figure 7-11**  
**Circuit Breaker Panel - Serials 0442 thru 0656, 0658 thru 0689 (1 of 2)**  
**P/N 13772-005**  
**Revision 1**

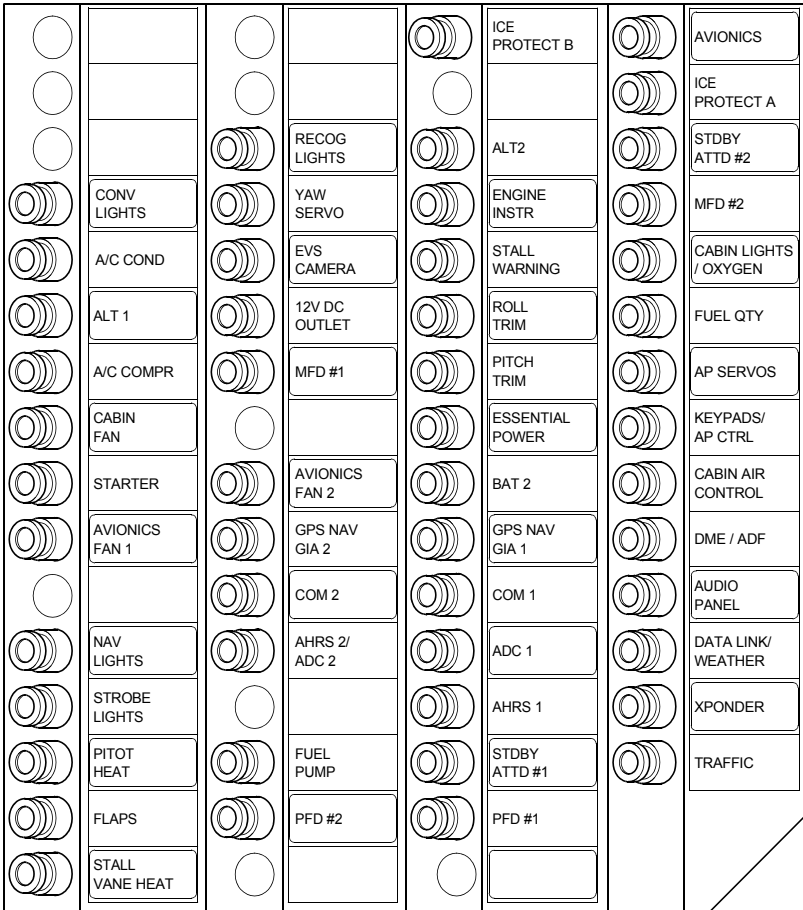

SR22\_FM07\_3635

**Figure 7-11**  
Circuit Breaker Panel - *Serials 0657, 0690 & subs (2 of 2)*

## Electrical System Control

The rocker type electrical system MASTER switches are 'on' in the up position and 'off' in the down position. The switches, labeled BAT 2, BAT 1, ALT 1, ALT 2 are located in the bolster switch panel immediately below the instrument panel. These switches, along with the AVIONICS power switch, control all electrical power to the airplane.

### ***Battery Switches***

The BAT 1 and BAT 2 switches control the respective battery. Setting the BAT 1 switch 'on' energizes a relay connecting BAT 1 to the MCU Distribution Buses (also energizing the circuit breaker panel buses) and the open contacts of the starter relay. Setting the BAT 2 switch 'on' energizes a relay connecting BAT 2 to the circuit breaker panel ESS BUS 1. Normally, for flight operations, all master switches will be 'on'. However, the BAT 1 and BAT 2 switches can be turned 'on' separately to check equipment while on the ground. Setting only the BAT 2 switch 'on' will energize those systems connected to the circuit breaker panel's ESS BUS 1 and ESS BUS 2. If any system on the other buses is energized, a failure of the Distribution Bus interconnect isolation diode is indicated. When the BAT 1 switch is set to 'on,' the remaining systems will be energized. To check or use non-essential avionics equipment or radios while on the ground, the AVIONICS power switch must also be turned on.

### ***Alternator Switches***

The ALT 1 and ALT 2 switches control field power to the respective alternator. For ALT 1 to start, the BAT 1 switch must be 'on'. Setting the ALT 1 switch 'on' energizes a relay allowing 28 VDC from the 5 amp ALT 1 circuit breaker on A/C BUS 1 to be applied to a voltage regulator for ALT 1. For ALT 2 to start, either the BAT 1 switch or the BAT 2 switch must be 'on.' Setting the ALT 2 switch 'on' energizes a relay allowing 28 VDC from the 5 amp ALT 2 circuit breaker on ESS BUS 2 to be applied to voltage regulator for ALT 2. Positioning either ALT switch to the OFF position removes the affected alternator from the electrical system.

#### **• Caution •**

Continued operation with the alternators switched off will reduce battery power enough to open the battery relay, remove power from the alternator field, and prevent alternator restart.

### ***Avionics Power Switch***

A rocker switch, labeled AVIONICS, controls electrical power from the circuit breaker panel (MAIN BUS 1) to the Avionics Bus. The switch is located next to the ALT and BAT Master switches. Typically, the switch is used to energize or de-energize all non-essential avionics on the AVIONICS bus simultaneously. With the switch in the OFF position, no electrical power will be applied to the non-essential avionics equipment, regardless of the position of the MASTER switch or the individual equipment switches. For normal operations, the AVIONICS switch should be placed in the OFF position prior to activating the MASTER switches, starting the engine, or applying an external power source.

### **Ground Service Receptacle**

A ground service receptacle is located just aft of the cowl on the left side of the airplane. This receptacle is installed to permit the use of an external power source for cold weather starting and maintenance procedures requiring reliable power for an extended period. The external power source must be regulated to 28 VDC. The external power control contactor is wired through the BAT 1 MASTER switch so that the BAT 1 switch must be 'on' to apply external power.

Refer to Section 8, [Ground Handling](#) for use of external power and special precautions to be followed.

## Electrical Indicating

Electrical system information is displayed as bar graphs and text on the MFD's ENGINE page. When the ENGINE page is not active or in the case of an electronic display failure (backup mode), Battery 1 ampere output and Essential Bus voltage output are displayed along the LH edge of the display. Electrical data is acquired by the Engine Airframe Unit which transmits the data to the Engine Indicating System for display as described in the following pages.

• Note •

A "Red X" through any electronic display field indicates that the display field is not receiving valid data and should be considered inoperative.

### ***Electrical System Annunciations***

Electrical system health, caution, and warning messages are displayed in color-coded text in the Crew Alerting System (CAS) window located to the right of the Altimeter and Vertical Speed Indicator. In combination with a CAS alert, the affected electrical parameter displayed on the ENGINE page changes to the corresponding color of CAS alert and the annunciation system issues an audio alert.

• Note •

For specific pilot actions in response to Electrical System Annunciations, refer to Section 3 - Emergency Procedures, [Electrical System Emergencies](#), and Section 3A - Abnormal Procedures, [Electrical System](#).

For additional information on Engine Instrument Markings and Annunciations, refer to [Section 2: Limitations](#).

For additional information on the System Annunciations And Alerts, refer to the [Perspective Integrated Avionics System](#) description in this section.

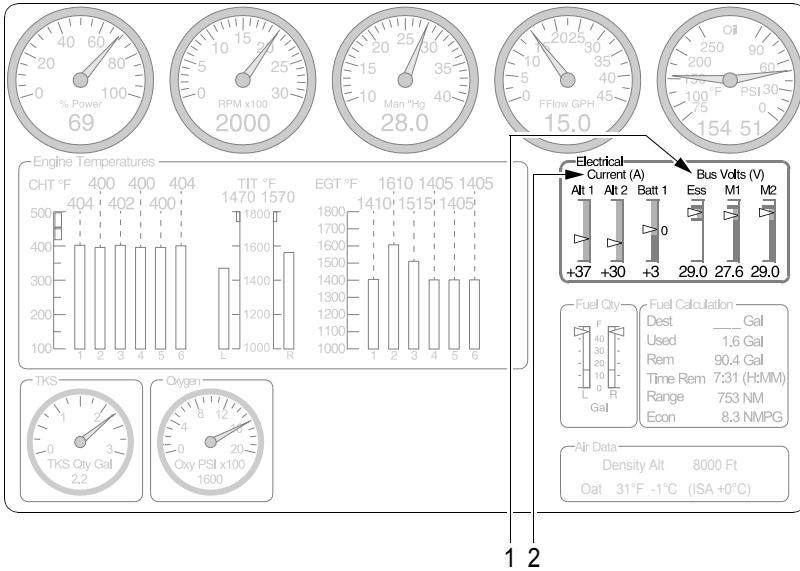

**Electrical System Indication**

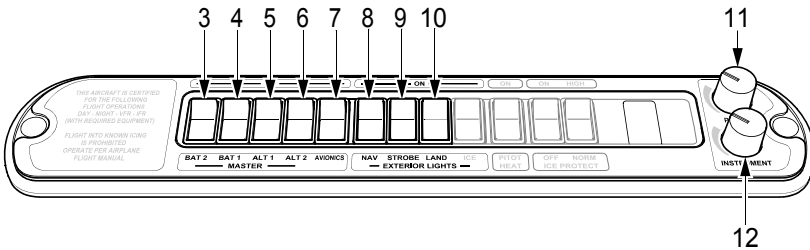

**Electrical and Lighting Controls**

**LEGEND**

- |                                 |                       |
|---------------------------------|-----------------------|
| 1. Essential & Main Bus Voltage | 7. Avionics           |
| 2. Alternator & Battery Current | 8. Navigation         |
| 3. Battery 2                    | 9. Strobe             |
| 4. Battery 1                    | 10. Landing Light     |
| 5. Alternator 1                 | 11. Panel Dimmer      |
| 6. Alternator 2                 | 12. Instrument Dimmer |

SR22\_FM07\_3257B

**Figure 7-12**  
**Electrical / Lighting Controls and Indicating**



# Lighting Systems

## Exterior Lighting

The airplane is equipped with wing tip navigation lights with integral anti-collision strobe lights and recognition Lights. The landing light is located in the lower cowl.

### ***Navigation Lights***

The airplane is equipped with standard wing tip navigation lights. The lights are controlled through the NAV light switch on the instrument panel bolster.

28 VDC for navigation light operation is supplied through the 5-amp NAV LIGHTS circuit breaker on the NON ESS BUS.

### ***Strobe Light***

Anti-collision strobe lights are installed integral with the standard navigation lights. Each strobe is flashed by a separate power supply. The strobe power supplies are controlled through the STROBE light switch on the instrument panel bolster.

28 VDC for strobe light and control circuits is supplied through the 5-amp STROBE LIGHTS circuit breaker on the NON ESS BUS.

### ***Landing Light***

A High Intensity Discharge (HID) landing light is mounted in the lower engine cowl. The landing light is controlled through the LAND light switch on the instrument panel bolster.

Setting the LAND light switch 'on' energizes the landing light control relay in the Master Control Unit (MCU) completing a 28 VDC circuit from the airplane Main Distribution Bus 1 to the light's ballast located on the firewall. The ballast provides boosted voltage to illuminate the HID lamp.

A 7.5-amp fuse on the Main Distribution Bus 1 in the MCU protects the circuit.

### ***Recognition Lights***

The airplane is equipped with recognition lights on the leading edge of the wing tips. The lights are controlled through the landing light switch on the instrument panel bolster.

28 VDC for recognition light operation is supplied through the 5-amp RECOG LIGHTS circuit breaker on the NON ESS BUS.

## Interior Lighting

Interior lighting for the airplane consists of overhead lights for general cabin lighting, individual lights for the pilots and passengers, and dimmable panel floodlights. The flight instrumentation and avionics equipment lights are dimmable.

### ***Instrument Lights***

Instrument lighting for the airplane includes: Primary Flight and Multifunction Display backlighting and bezel, bolster switch panel, audio panel keys, FMS keyboard, and optionally installed GMC 705 AFCS Control Unit, incandescent lights in the standby instrument bezels, key backlighting and status lighting for the flap and Environmental Control System (ECS) control panels. Associated lighting is adjustable through the INSTRUMENT dimmer control on the instrument panel bolster. The dimmer is OFF when rotated fully counterclockwise, all systems revert to daytime lighting in this position (not full DIM).

In daytime lighting (knob OFF/full counterclockwise):

- Standby instruments, all Avionics system keypads and the bolster switch panel are unlit
- MFD and PFD screen illumination is controlled by automatic photocell (providing full brightness in high light conditions, only slightly reduced by darkness)
- ECS and control panels are backlight and their status lights at maximum intensity

With active dimming (knob moved clockwise), the full bright position (full clockwise) applies maximum illumination to keys and switches, to standby instruments and to status lights, but the PFD/MFD screen illumination is at a substantially reduced level (levels still appropriate for night flight). Maximum screen illumination (appropriate for daytime use) is with the dimmer OFF/full counterclockwise.

The instrument light circuits operate on 28 VDC supplied through the 5-amp CABIN LIGHTS circuit breaker on MAIN BUS.

### ***Panel Flood Lights***

A string of red LEDs mounted under the instrument panel glareshield provide flood lighting for the instrument panel. The lights are controlled through the PANEL dimmer control on the instrument panel bolster.

The panel lights operate on 28 VDC supplied through the 5-amp CABIN LIGHTS circuit breaker on MAIN BUS 1.

### ***Reading Lights***

Individual eyeball-type reading lights are installed in the headliner above each passenger position. Each light is aimed by positioning the lens in the socket and is controlled by a push-button switch located next to the light. The pilot and copilot reading lights are also dimmable through the PANEL lights control on the instrument panel bolster. The reading lights are powered by 28 VDC supplied through the 5-amp CABIN LIGHTS circuit breaker on MAIN BUS 1.

### ***Overhead Dome Light***

General cabin lighting is provided by a dome light located in the headliner at the approximate center of the cabin.

#### ***Serials 0442 thru 1232:***

The dome light is controlled through the OVERHEAD light control on the instrument panel bolster or by the switch next to the light assembly on the ceiling of the airplane. On airplane with OVERHEAD light control on the instrument panel bolster, rotating the knob clockwise from the off position will illuminate the light and control its intensity.

The dome light is powered by 28 VDC supplied through the 5-amp CABIN LIGHTS circuit breaker on MAIN BUS 1.

#### ***Serials 1233 & subs w/o Convenience Lighting:***

The dome light is controlled through the cabin light switch located next to the light assembly on the ceiling of the airplane.

The dome light is powered by 28 VDC supplied through the 5-amp CABIN LIGHTS circuit breaker on MAIN BUS 1.

## Convenience Lighting

*Serials 1233 & subs w/ Convenience Lighting:*

The convenience lighting option consists of the overhead dome light, overhead baggage compartment lights, interior footwell lights, exterior entry step lights, and a key fob.

### ***Overhead Dome Light***

General cabin lighting is provided by a dome light located in the headliner at the approximate center of the cabin.

### ***Overhead Baggage Compartment Lights***

General baggage compartment lighting is provided by lights located in the headliner.

### ***Footwell Lights***

General floor lighting is provided by footwell lights located throughout the cabin.

### ***Entry Step Lights***

Illumination of the entry steps is provided by lights located above each step.

Convenience lighting is controlled by the cabin light switch located on the ceiling of the airplane. 28 VDC for convenience lighting is supplied through the 3-amp CONV LIGHTS circuit breaker on the CONS BUS.

### ***Key Fob***

Remote operation of the door locks is provided by a battery-powered key fob. Refer to [Cabin Doors](#) description in this section.

### ***Convenience Lighting Operation***

When the cabin light switch is in the ON position:

- Dome light and footwell lights will turn on.
- Entry step lights will turn on when either cabin door is opened or the doors are unlocked via the key fob and will turn off when both cabin doors are closed or the doors are locked via the key fob.
- Baggage compartment lights will turn on when baggage door is opened and will turn off when baggage door is closed.

When the cabin light switch is in the OFF position:

- Dome light, baggage compartment lights, footwell lights, and entry step lights will turn off.

When the cabin light switch is in the AUTO position:

- Dome light, footwell lights, and entry step lights will turn on when either cabin door is opened or the doors are unlocked via the key fob and will turn off when both cabin doors are closed or the doors are locked via the key fob.
- Baggage compartment lights will turn on when baggage door is opened and will turn off when baggage door is closed.

When aircraft power is turned off all convenience lighting will turn off after several minutes of illumination.

## Environmental System

• Note •

To facilitate faster cabin cooling, prior to engine start leave the cabin doors open for a short time to allow hot air to escape.

Standard cabin heating and ventilation is accomplished by supplying conditioned air from the heat exchanger for heating and windshield defrost and fresh outside air for ventilation. The environmental system consists of a fresh air inlet in the RH cowl, a heat exchanger around the exhaust system crossover tube, an air mixing chamber, air ducting for distribution, a distribution manifold, a windshield diffuser, crew and passenger air vents, and associated plumbing, controls, actuators, wiring for system flow-selection and temperature control

An optional 3-speed blower fan is available to supplement airflow when ram air may be inadequate such as during ground operation.

28 VDC for Environmental System Control Panel operation is supplied through the 2-amp CABIN AIR CONTROL breaker on MAIN BUS 1.

The optional Blower Fan is powered by 28 VDC supplied through a 15-amp CABIN FAN breaker on A/C BUS 2.

### ***Serials with Optional Air Conditioning System:***

The optionally installed Air Conditioning System is designed to cool the cabin to desired temperature settings and maintain comfortable humidity levels. The system consists of an engine driven compressor, condenser assembly, evaporator assembly, exhaust heat exchanger, fresh air inlet, air-mixing chamber, blower fan, distribution manifold, ducting, windshield diffuser, vent outlets, associated plumbing, controls, actuators, wiring for system flow-selection and temperature control.

28 VDC for Air Conditioner Condenser operation is supplied through the 15-amp A/C COND breaker on A/C BUS 1.

28 VDC for Air Conditioner Compressor operation is supplied through the 5-amp A/C COMPR breaker on A/C BUS 2.

The airplane engine must be running for the air conditioner to operate.

### **Distribution**

Ventilation and cooling is provided by ducting fresh air from a NACA inlet on the RH cowl to the mixing chamber located on the lower RH portion of the firewall. Depending on operating mode and temperature

selection, the air in the mixing chamber is ducted directly into the distribution system or, if in optional air conditioning mode, is further cooled as it passes through the evaporator assembly located under the front passenger seat. Heating is accomplished by mixing ventilation air from the fresh air inlet with heated air provided by the heat exchanger in the mixing chamber on the firewall. From the mixing chamber - which also controls airflow into the cabin compartment - the conditioned air is forced by ram air pressure or by blower fan into a distribution manifold mounted to the center, aft side of the firewall. The distribution manifold uses butterfly valves to control airflow to the floor and defrost vents. Airflow is ducted directly to all panel air vents.

Crew panel air vents are located inboard on the RH and LH bolster panels and on the outboard section of the instrument panel. The crew floor air vents are mounted to the bottom of each kick plate. The passenger panel air vents are chest high outlets mounted in the armrests integral to the LH and RH cabin wall trim panels. The passenger floor air vents are mounted to the bottom portion of the LH and RH cabin wall trim panels. The windshield diffuser, located in the windshield assembly, directs conditioned air to the base of the windshield.

## Heating

Ram air from the rear ports of the intercoolers is ducted to a heat exchanger surrounding the exhaust system crossover tube. The heated air is then routed to the hot air valve, mounted to the forward side of the firewall, which controls entry of hot air into the cabin distribution system. When the valve is open, the air flows into the cabin mixing chamber. When the valve is closed, the heated air exits into the engine compartment and is exhausted overboard with the engine cooling airflow.

Cabin heat is regulated by controlling the volume of hot air admitted into the distribution system's air mixing chamber. The proportion of heated air to fresh air is accomplished using the temperature selector mounted on the RH instrument panel. For over-temperature protection (the turbocharger bleed air is further heated, under some conditions the hot air source temperature may be in excess of 300°F), the controller monitors mixed air temperature through a sensor downstream of the mixing chamber. If mixed air temperature exceeds duct temperature limit, the hot air flow is reduced and fresh airflow increased until temperature is reduced. Valves are automatically

cycled to ensure supply temperature is maintained below duct temperature limits.

Conditioned air can be directed to passengers and/or the windshield diffuser by manipulating the cabin vent selector mounted on the RH instrument panel. The conditioned air enters the cabin through adjustable air vents located in each kick plate and through non-adjustable, floor level vents located in the rear cabin trim side panels. Conditioned air can also be distributed to the windshield diffuser in the glareshield.

## **Cooling**

Standard cabin cooling is provided by ram air admitted through the NACA inlet on the RH cowl to the fresh air valve, mounted to the forward side of the firewall. When the fresh air valve is open, the air flows into the cabin mixing chamber. When the fresh air valve is closed, the cooled air exits into the engine compartment and is exhausted overboard with the engine cooling airflow.

For airplane with optionally equipped Air Conditioning System, R134A refrigerant enters the engine mounted compressor as a vapor and is pressurized until the heat-laden vapor reaches a point much hotter than the outside air. The compressor then pumps the vapor to the condenser where it cools, changes to a liquid, and passes to the receiver-drier. The receiver-drier's function is to filter, remove moisture, and ensure a steady flow of liquid refrigerant into the evaporator through the expansion valve - a temperature controlled metering valve which regulates the flow of liquid refrigerant to the evaporator. Inside the evaporator, the liquid refrigerant changes state to a gas and in doing so, absorbs heat. The evaporator then absorbs the heat from the air passing over the coils and the moisture from the air condenses and is drained overboard through the belly of the airplane. From the evaporator, the refrigerant vapor returns to the compressor where the cycle is repeated. During normal air conditioning operation, ram air from the fresh air intake flows into the evaporator assembly, is cooled as it passes through the evaporator coils, and is then ducted forward to the distribution manifold. During maximum air conditioning operation - or recirculation mode - the fresh air valve closes and valves in the evaporator assembly open allowing cabin air to be recirculated and further cooled as the air passes through the evaporator coils and ducted forward to the distribution manifold.



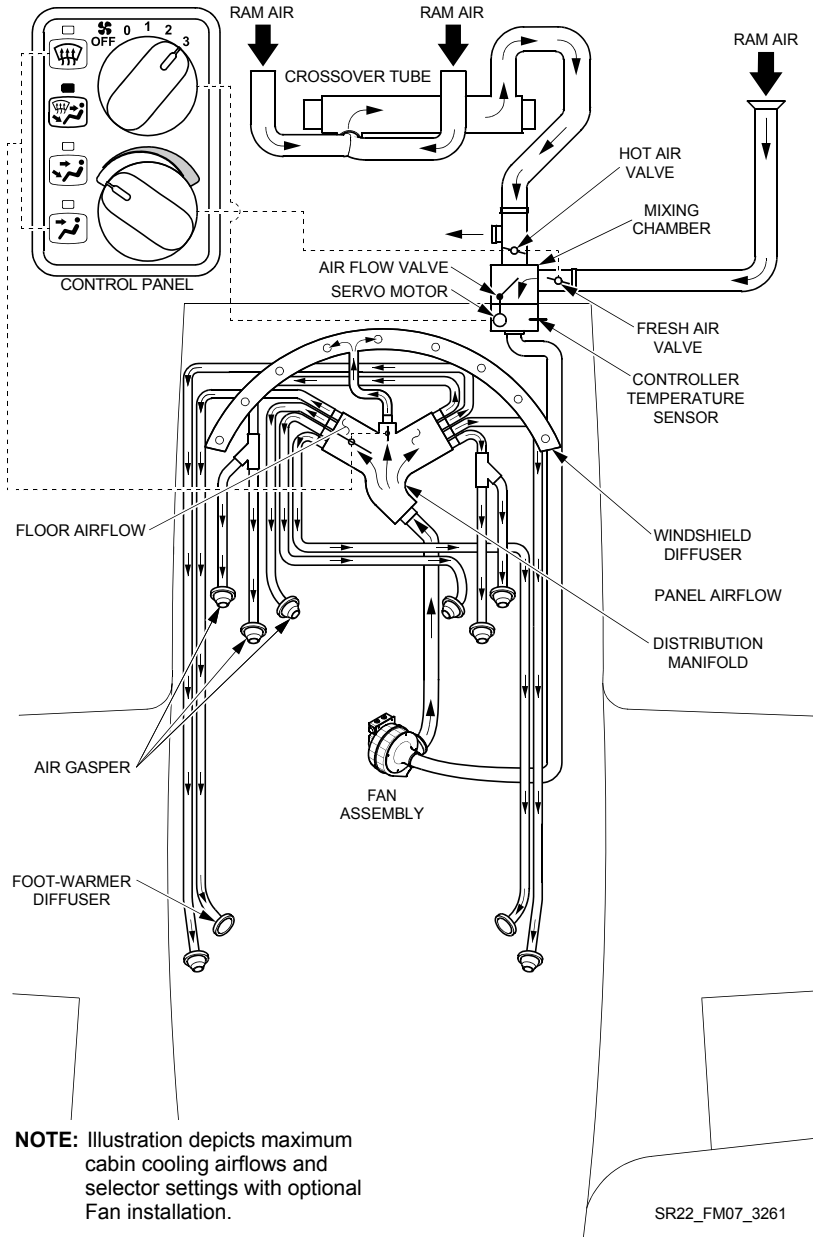

**Figure 7-13**  
**Standard Environmental System**

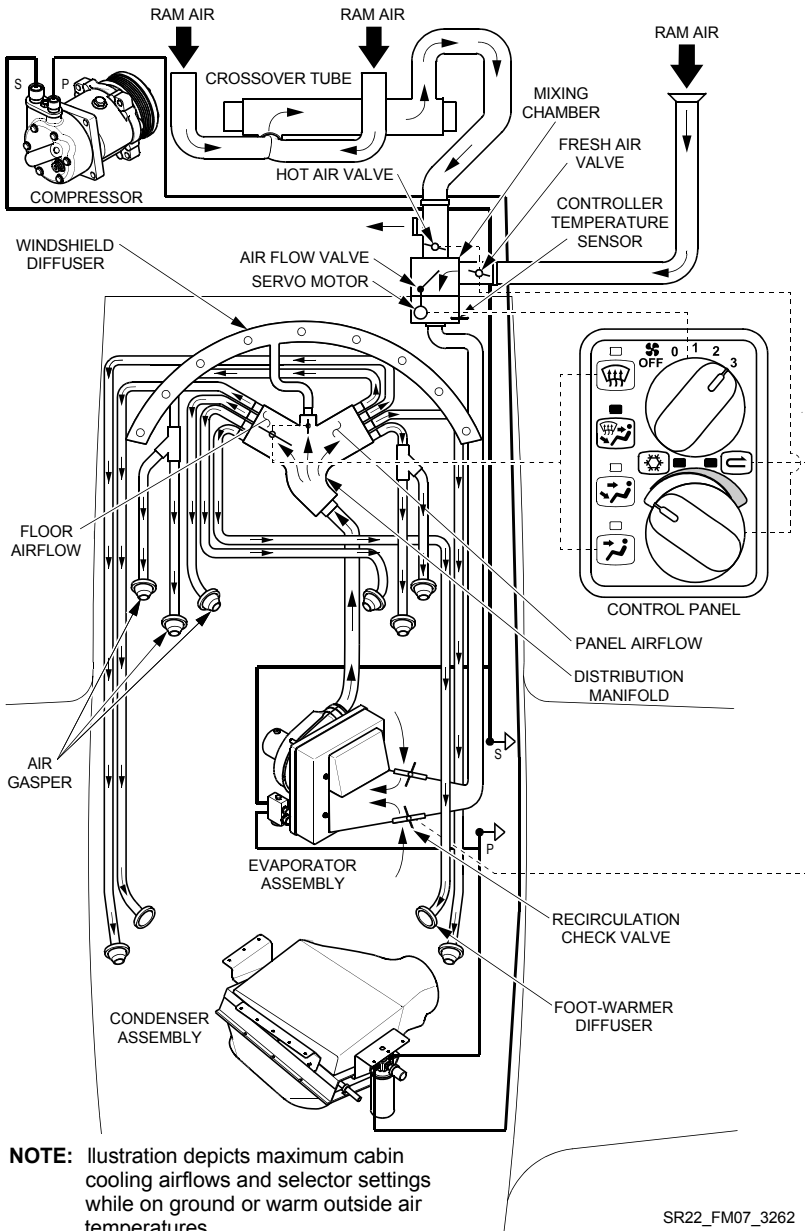

**Figure 7-14**  
**Optional Air Conditioning System**

## Airflow Selection

The airflow selector on the system control panel regulates the volume of airflow allowed into the cabin distribution system. When the airflow selector is moved past the OFF position an electro-mechanical linkage actuates a valve in the mixing chamber on the forward firewall to the full open position. The air is then distributed by either ram air or by an optional blower fan to the distribution manifold mounted to the center, aft side of the firewall. The optional blower fan system includes 0 (ram air), 1 (low fan), 2 (med fan), and 3 (high fan) airflow settings.

## Vent Selection

Air from the distribution manifold is proportioned and directed to passengers and/or the windshield by pressing the cabin vent selector buttons which electrically actuate butterfly valves at the entrances to the windshield diffuser and the cabin floor ducting.

When the Temperature Selector is in the blue "cool" zone, there is continuous ram airflow to the panel and armrest eyeball outlets. Each occupant can control the flow rate from 'off' to maximum by rotating the nozzle.

When the Panel selector button is pushed, both butterfly valves are closed providing maximum airflow to the instrument panel and armrest eyeball outlets.

Pressing the Panel-Foot selector button opens the cabin floor butterfly valve allowing airflow to the rear seat foot warmer diffusers and the front seat outlets mounted to the underside of each kickplate.

Selecting Panel-Foot-Windshield button opens the windshield diffuser butterfly valve which permits shared airflow to the defrosting mechanism and cabin floor outlets.

When the Windshield selector button is pushed the cabin floor butterfly valve is closed providing maximum airflow to the windshield diffuser.

## **Temperature Selection**

The temperature selector is electrically linked to the hot and cold air valves. Rotating the selector simultaneously opens and closes the two valves, permitting hot and cold air to mix and enter the distribution system. Rotating the selector clockwise, permits warmer air to enter the system - counterclockwise, cooler air.

On airplane with the optional Air Conditioning System installed, when the air conditioning button (snowflake) is pushed, the valve on the firewall completely closes and the air-conditioner is activated. When recirculation button is pushed, the fresh air valve completely closes and cabin air is recirculated to provide for maximum air conditioning operation. When the air conditioning system is on and the temperature selector is rotated to the full cool position, recirculating mode can be activated to provide maximum cabin cooling. Air conditioning or recirculating mode is not available when the airflow fan selector is in the "0" position. Recirculating mode is not available unless the air conditioning system is operating.

Rotating the selector controls the volume of airflow allowed into the cabin distribution system through use of an electro-mechanical linkage to a butterfly (hot air) valve in the mixing chamber on the forward firewall. When the airflow selector fan speed is moved to the 1, 2, or 3 position the electro-mechanical linkage actuates the hot air valve to the full open position and the 3-speed blower fan is turned on.

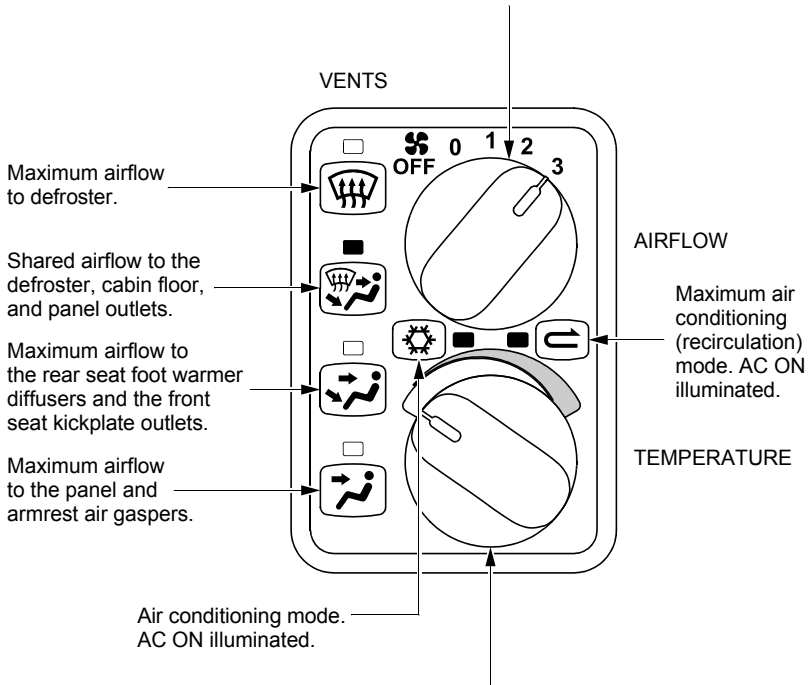

Rotating the selector simultaneously opens and closes the hot and fresh air butterfly valves, permitting conditioned (mixed) air to enter distribution system.

**NOTE:** Illustration depicts settings for Emergency Procedures Smoke and Fume Elimination. If source of smoke and fume is firewall forward, turn Airflow Selector OFF.

SR20\_FM09\_3362

**Figure 7-15**  
**Environmental System Operation**

## Stall Warning System

The airplane is equipped with an electro-pneumatic stall warning system to provide audible warning of an approach to aerodynamic stall. The system consists of an inlet in the leading edge of the right wing, a pressure switch and associated plumbing, and the avionics system aural warning system.

As the airplane approaches a stall, the low pressure on the upper surface of the wings moves forward around the leading edge of the wings. As the low pressure area passes over the stall warning inlet, a slight negative pressure is sensed by the pressure switch. The pressure switch then provides a signal to cause the warning horn to sound, the red STALL warning CAS annunciation to illuminate, and, if engaged, the autopilot system to disconnect.

The warning sounds at approximately 5 knots above stall with full flaps and power off in wings level flight and at slightly greater margins in turning and accelerated flight.

The system operates on 28 VDC supplied through the 2-amp STALL WARNING circuit breaker on the ESS BUS 2.

## Pitot-Static System

The Pitot-Static system consists of a single heated Pitot tube mounted on the left wing and dual static ports mounted in the fuselage. The Pitot heat is pilot controlled through a panel-mounted switch. An internally mounted alternate static pressure source provides backup static pressure should that the primary static source becomes blocked. Water traps with drains, under the floor in the cabin, are installed at each Pitot and static line low point to collect any moisture that enters the system. The traps should be drained at the annual inspection and when water in the system is known or suspected.

### Pitot Heat Switch

The heated Pitot system consists of a heating element in the Pitot tube, a rocker switch labeled PITOT HEAT, and associated wiring. The switch and circuit breaker are located on the left side of the switch and control panel. When the Pitot heat switch is turned on, the element in the Pitot tube is heated electrically to maintain proper operation in possible icing conditions. The Pitot heat system operates on 28 VDC supplied through the 7.5-amp PITOT HEAT circuit breaker on the NON-ESSENTIAL BUS.

### Pitot Heat Annunciation

Illumination of the PITOT HEAT FAIL Caution indicates that the Pitot Heat switch is ON and the Pitot heater is not receiving electrical current. Illumination of PITOT HEAT REQD Caution indicates the system detects OAT is less than 41°F (5°C) and Pitot Heat Switch is OFF. A current sensor on the Pitot heater power supply wire provides current sensing.

### Alternate Static Source

An alternate static pressure source valve is installed on the switch and control panel to the right of the pilot's leg. This valve supplies static pressure from inside the cabin instead of the external static port. If erroneous instrument readings are suspected due to water or ice in the pressure line going to the standard external static pressure source, the alternate static source valve should be turned on. Pressures within the cabin will vary with open heater/vents. Whenever the alternate static pressure source is selected, refer to [Section 5: Performance Data](#) for airspeed calibration and altitude corrections to be applied.

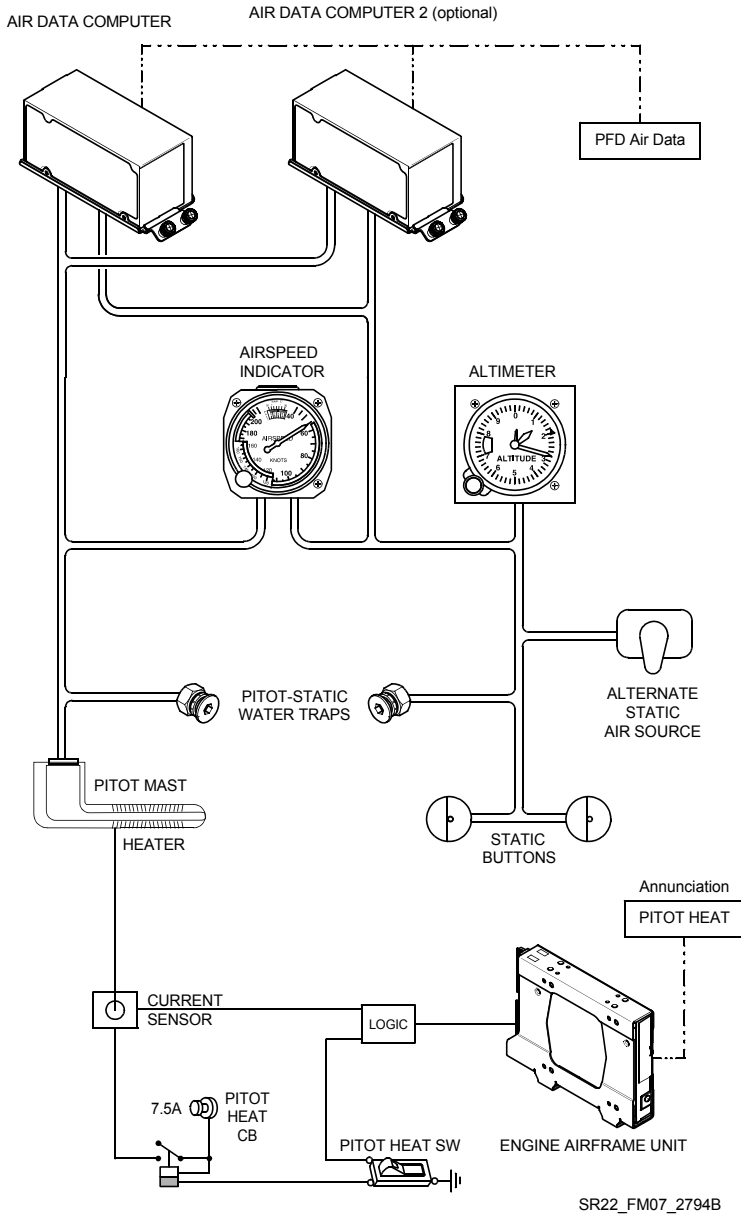

**Figure 7-16**  
**Pitot-Static System - Serials w/o MD302 (1 of 2)**



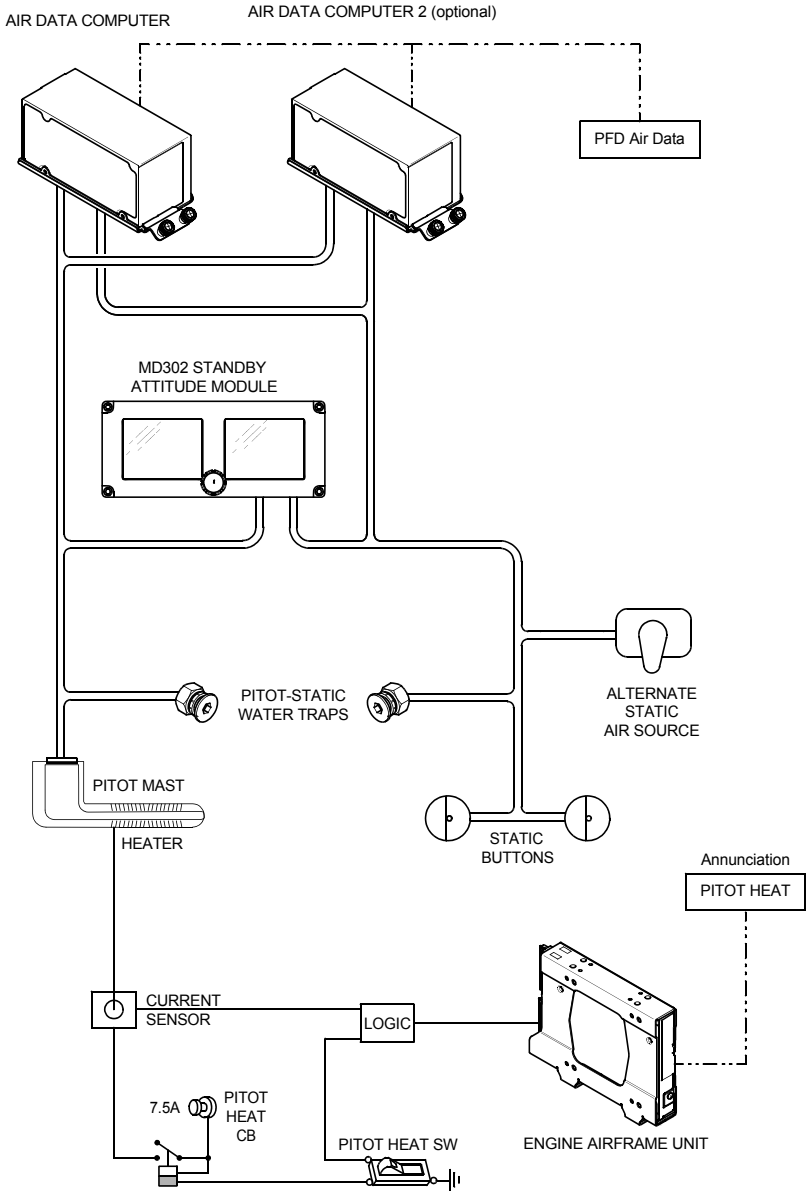

SR22\_FM07\_4248

**Figure 7-16**  
**Pitot-Static System - Serials 0954, 0963 & subs w/ MD302 (2 of 2)**  
P/N 13772-005  
Revision 1

## Avionics

### Perspective Integrated Avionics System

The Perspective Integrated Avionics System provides advanced cockpit functionality and improved situational awareness through the use of fully integrated flight, engine, communication, navigation and monitoring equipment. The system consists of the following components:

- GDU Primary Flight Display (PFD)
- GDU Multifunction Display (MFD)
- GCU 478 Flight Management System Keyboard
- GRS 77 Attitude and Heading Reference System
- GDC 74A Air Data Computer
- GIA 63W Integrated Avionics Units
- GEA 71 Engine Airframe Unit
- GTX 32 Mode A, C, or GTX 33 Mode S, or GTX 33 ES Mode S with Extended Squitter (Optional)
- GMA 350 Audio Panel with Marker Beacon Receiver
- GFC 700 3-Axis Autopilot and GMC 705 Controller
- GSR 56 Iridium Global Satellite Datalink (Optional)
- GDL 69/69A XM Satellite Weather/Radio Receiver (Optional)
  - GRT 10 XM Radio Remote Transceiver (Optional)
  - GRC 10 XM Radio Remote Control (Optional)
- Traffic Advisory System (Optional)
- Weather Information System (Optional)
- Bendix/King KR 87 Automatic Direction Finder (Optional)
- Bendix/King KN 63 Distance Measuring Equipment (Optional)
- Synthetic Vision System (Optional)
- Max Viz Enhanced Vision System (Optional)
- MD302 Standby Attitude Module (Optional)

Refer to the Perspective Integrated Avionics System Pilot's Guide for a detailed description of the system and its operating modes.

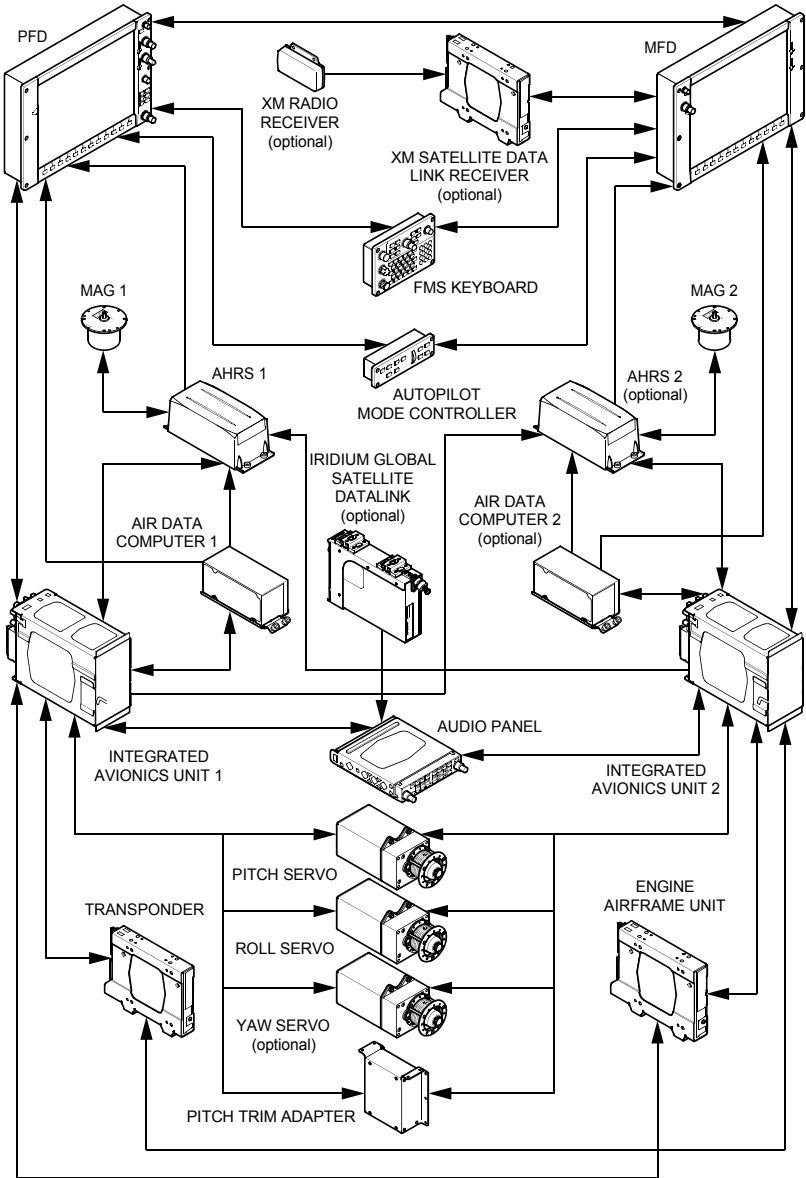

SR22\_FM07\_3574

**Figure 7-17**  
**Perspective Integrated Avionics System Schematic**

### ***GDU Primary Flight Display***

The Primary Flight Display, located directly in front of the pilot, is intended to be the primary display of flight parameter information (attitude, airspeed, heading, and altitude) during normal operations. The PFD accepts data from a variety of sources, including the MFD and the Integrated Avionics Units through a high-speed data bus connection. In conjunction with Flight Management System Keyboard, the PFD also controls and displays all communication and navigation frequencies as well as displaying warning/status annunciations on airplane systems. During engine start, reversionary operation (MFD failure), or when the DISPLAY BACKUP switch is selected, engine system information is displayed on the PFD.

Redundant power sources provide 28 VDC for PFD operation. Power is supplied through the 5-amp PFD 1 circuit breaker on the ESS BUS 1 and the 5-amp PFD 2 circuit breaker on MAIN BUS 2. Either circuit is capable of powering the PFD. System start-up is automatic once power is applied. Power-on default brightness is determined by ambient lighting and is user adjustable. Typical alignment time is 60 seconds from battery turn on.

#### Display Backup Mode

In the event of a detected display failure, the Integrated Avionics System automatically switches to Display Backup Mode. In Display Backup Mode, all essential flight information from the PFD is presented on the remaining display in the same format as in normal operating mode with the addition of the Engine Indicating System. The change to backup is completely automated and no pilot action is required. However, if the system fails to detect a display problem, Display Backup Mode may be manually activated by pressing the red DISPLAY BACKUP Button. Pressing this button again deactivates Display Backup Mode.

### ***GDU Multifunction Display***

The Multifunction Display, located above the center console, depicts navigation, terrain, lightning, traffic data, NAV/COM frequencies, and annunciation information. All engine data is displayed on a dedicated ENGINE page. When the ENGINE page is not shown, all essential engine information is shown on an engine strip at the edge of the display.

Redundant power sources provide 28 VDC for MFD operation. Power is supplied through the 5-amp MFD 1 circuit breaker on the MAIN BUS

3 and the 5-amp MFD 2 circuit breaker on MAIN BUS 1. Either circuit is capable of powering the MFD. System start-up is automatic once power is applied. Power-on default brightness is determined by ambient lighting and is user adjustable.

### ***GCU 478 Flight Management System Keyboard***

The Flight Management System Keyboard is found on the upper section of the center console and is the primary interface for avionics system data entry, PFD/MFD operation, NAV/COM tuning, and heading, course and altitude selection.

28 VDC for Flight Management System Keyboard operation is supplied through the 5-amp KEYPADS / AP CTRL circuit breaker on MAIN BUS 1.

### ***GRS 77 Attitude and Heading Reference System (AHRS)***

The Attitude and Heading Reference System (AHRS) unit(s), mounted behind the PFD, provide airplane attitude and heading information to both the PFD and the primary Air Data Computer. The AHRS units(s) contain advanced sensors (including accelerometers and rate sensors) and interfaces with the: primary Magnetometer to obtain magnetic field information, the Air Data Computer to obtain air data, and both Integrated Avionics Units to obtain GPS information.

28 VDC for AHRS 1 operation is supplied through the 5-amp AHRS 1 circuit breaker on the ESS BUS 1. If option installed, 28 VDC for AHRS 2 operation is supplied through the 5-amp AHRS 2 circuit breaker on the MAIN BUS 2.

### ***GDC 74A Air Data Computer (ADC)***

The Air Data Computer(s), mounted behind the instrument panel to the right of the MFD, process data from the Pitot/Static system and outside air temperature (OAT) sensor(s). This unit(s) provide pressure altitude, airspeed, vertical speed and OAT information to the Integrated Avionics System, and communicate with the primary PFD, Integrated Avionics Unit, and AHRS units. The Air Data Computer(s) is also connected directly to the Outside Air Temperature probe(s) and Pitot-Static System.

28 VDC for ADC 1 operation is supplied through the 5-amp ADC 1 circuit breaker on the ESS BUS 1. If option installed, 28VDC for ADC 2 operation is supplied through a 5-amp AHRS 2 / ADC 2 circuit breaker on the MAIN BUS 2.

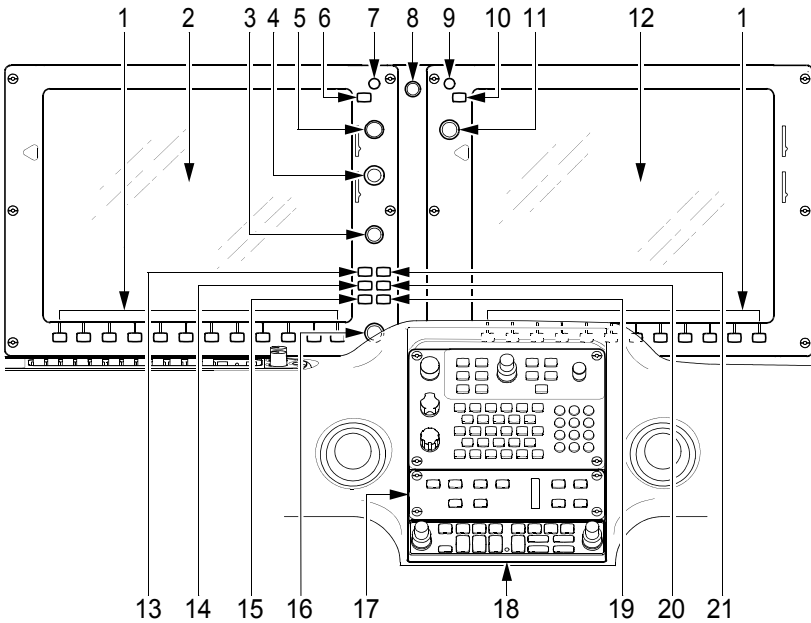

**Legend**

- |  |                                      |
|--|--------------------------------------|
| 1. Soft Keys                                     | 11. NAV Transceiver Selection & Tune |
| 2. PFD   | 12. MFD                              |
| 3. PFD Range/Pan Joystick                        | 13. PFD Direct-to-Course             |
| 4. Barometric Pressure                           | 14. PFD Flight Plan Page             |
| 5. COM Transceiver Selection & Tune              | 15. PFD Clear/Cancel Information     |
| 6. COM Frequency Transfer<br>(& 121.5 Emer Tune) | 16. PFD Flight Management System     |
| 7. COM Volume and Squelch                        | 17. GFC 705 Mode Controller          |
| 8. Display Backup Selection                      | 18. Audio Panel                      |
| 9. NAV and ID Audio Volume                       | 19. PFD Enter Key                    |
| 10. NAV Frequency Transfer                       | 20. PFD Procedures                   |
|  | 21. PFD Menu Key                     |

SR22\_FM07\_3575B

**Figure 7-18**  
**Perspective Integrated Avionics System (Sheet 1 of 2)**

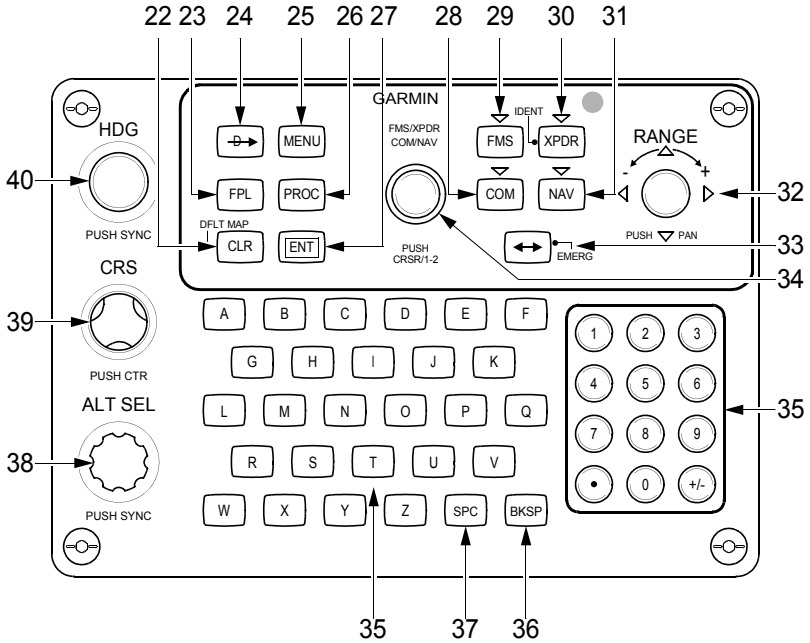

Flight Management System Keyboard

**Legend**

- |  |                                     |
|--|-------------------------------------|
| 22. MFD Clear/Cancel Information (Default Map) | 31. NAV Tuning Mode                 |
| 23. MFD Flight Plan Page                       | 32. MFD Range/Pan Joystick          |
| 24. MFD Direct-to-Course                       | 33. Frequency Transfer (121.5 Tune) |
| 25. MFD Menu                                   | 34. MFD FMS XPDR/NAV/COM Control    |
| 26. MFD Procedures                             | 35. Alphanumeric Keys               |
| 27. MFD Enter Key                              | 36. Backspace Key                   |
| 28. COM Tuning Mode                            | 37. Space Key                       |
| 29. FMS Mode                                   | 38. Altitude Selection (PFD)        |
| 30. Transponder Mode (Ident)                   | 39. Course Selection (HSI)          |
|  | 40. Heading Selection (PFD HSI)     |

SR22\_FM07\_2821

**Figure 7-18**  
**Perspective Integrated Avionics System (Sheet 2 of 2)**

### ***GIA 63W Integrated Avionics Units***

The Integrated Avionics Units, located behind the MFD and instrument panel, function as the main communication hub, linking all Integrated Avionics System components with the PFD. Each Integrated Avionics Unit contains a GPS WAAS receiver, VHF COM/NAV/GS receivers, system integration microprocessors, and flight director if the optional AFCS is installed. The Integrated Avionics Units are not paired together and do not communicate with each other directly.

28 VDC for Integrated Avionics Unit 1 operation is supplied through the 7.5-amp COM 1 and 5-amp GPS NAV GIA 1 circuit breakers on the ESS BUS 1. 28 VDC for Integrated Avionics Unit 2 operation is supplied through the 7.5-amp COM 2 and 5-amp GPS NAV GIA 2 circuit breakers on the MAIN BUS 2.

### ***GEA 71 Engine Airframe Unit***

The Engine Airframe Unit, mounted behind the MFD, receives and processes analog signals from the fuel gaging system, CHT, EGT, MAP, RPM and other sensors and transmits this data to the Integrated Avionics Unit.

28 VDC for Engine Airframe Unit operation is supplied through the 3-amp ENGINE INSTR circuit breaker on the ESS BUS 2.

### ***GTX 32 Transponder***

The GTX 32 solid-state transponder communicates with the primary Integrated Avionics Unit and provides Modes A and C interrogation/reply capabilities. The transponder is controlled via the PFD or Flight Management System Keyboard and is located in the empennage avionics compartment.

28 VDC for Transponder operation is supplied through the 2-amp XPONDER circuit breaker on AVIONICS BUS. Refer to the Perspective Integrated Avionics System Pilot's Guide for a complete description of the system, its operating modes, and additional detailed operating procedures.



### ***GMA 350 Audio Panel with Marker Beacon Receiver***

The 350 Audio Panel, installed on the center console below the Flight Management System Keyboard, integrates NAV/COM digital audio, intercom and marker beacon controls. The VHF communications portion of the unit interfaces with both Integrated Avionics Units to provide external radio communication, receive and demodulate VOR, Localizer, and Glide Slope signals.

28 VDC for Audio Panel operation is supplied through the 5-amp AUDIO PANEL circuit breaker on the AVIONICS bus.

• Note •

COM swap mode is not available in this installation.

For a detailed operating instructions, refer to the GMA 350 Audio Panel Pilot's Guide.

### ***Annunciation and Alert System***

Aircraft annunciations and alerts are displayed in the Crew Alerting System (CAS) window located to the right of the altimeter and VSI. Aircraft annunciations are grouped by criticality and sorted by order of appearance with the most recent message on top. The color of the message text is based on its urgency and required action:

- Warning (red) – Immediate crew awareness and action required.
- Caution (yellow) – Immediate crew awareness and future corrective action required.
- Advisory (white) – Crew awareness required and subsequent action may be required.

In combination with the CAS Window, the system issues an audio alert when specific system conditions are met and an expanded description of the condition is displayed in the Alerts Window located in the lower RH corner of the PFD.

• Note •

For specific pilot actions in response to System Annunciations, refer to [Section 3: Emergency Procedures](#) and [Section 3A: Abnormal Procedures](#).

For additional information on Engine Instrument Markings and Annunciations, refer to [Section 2: Limitations](#).

### ***GFC 700 3-Axis Autopilot and GMC 705 Autopilot Controller***

Refer to latest revision of AFM Supplement 13772-135 [GFC 700 Automatic Flight Control System](#) for operating information.

## Optional Avionics

### ***GTX 33 Mode S and GTX 33 ES Mode S Transponders***

The GTX 33 Mode S and GTX 33 ES Mode S solid-state transponders communicate with the primary Integrated Avionics Unit and provide Modes A, C, and S interrogation/reply capabilities. The GTX 33 ES Mode S transponder includes Extended Squitter ADS-B Out. The transponders are controlled via the PFD or Flight Management System Keyboard and are located in the empennage avionics compartment.

28 VDC for Mode S Transponder operation is supplied through the 2-amp XPONDER circuit breaker on AVIONICS BUS. Refer to the Perspective Integrated Avionics System Pilot's Guide for a complete description of the system, its operating modes, and additional detailed operating procedures.

### ***GSR 56 Iridium Satellite Network Transceiver***

The Iridium Satellite Network Transceiver, mounted in the empennage avionics compartment, communicates with the primary Integrated Avionics Unit and Audio Panel to provide near real-time weather, voice, and data services to the cabin audio system and integrated displays. The GSR 56 receives near real-time satellite weather information for display on the MFD and PFD and can also provide telephone/voice communications and text messaging (SMS) through the Iridium Satellite Network. The voice service is available through the audio panel via the TEL (telephone) input selection. SMS and weather products are displayed on the MFD.

28 VDC for Iridium Satellite Network Transceiver operation is supplied through the 5-amp DATA LINK/WEATHER circuit breaker on AVIONICS BUS. Refer to the Perspective Integrated Avionics System Pilot's Guide for a complete description of the system, its operating modes, and additional detailed operating procedures.

### ***GDL 69/69A XM Satellite Weather and Radio***

The Data Link Satellite Receiver, mounted in the empennage avionics compartment, receives and transmits real-time weather information to the MFD and PFD. If GDL 69A option is installed, this unit also provides digital XM audio entertainment to the cabin audio system via the GRT 10 XM Radio Remote Transceiver, mounted in the empennage avionics compartment and controlled by the GRC 10 Remote Control.

28 VDC for Satellite Datalink Receiver operation is supplied through the 5-amp WEATHER/DATA LINK circuit breaker on AVIONICS BUS. Refer to the Perspective Integrated Avionics System Pilot's Guide for a complete description of the system, its operating modes, and additional detailed operating procedures.

### ***Traffic Advisory System***

The Traffic Advisory System (TAS) advises the pilot of transponder-equipped airplane that may pose a collision threat. TAS information is displayed on the MFD and indicates the relative range, bearing, and altitude of intruder airplane. The Traffic Advisory System consists of a Transmitter Receiver Computer under the LH cockpit seat, and two directional antennas installed on the airplane exterior. The system utilizes inputs from the secondary Integrated Avionics Units via the primary Air Data Computer and is controlled via the MFD or Flight Management System Keyboard.

28 VDC for Traffic Advisory System operation is supplied through the 5-amp TRAFFIC circuit breaker on AVIONICS BUS. Refer to the Perspective Integrated Avionics System Pilot's Guide for a general description of the system and its operating modes.

### ***Stormscope WX-500 Weather Mapping Sensor***

The Stormscope WX-500 System detects electrical discharges associated with thunderstorms and displays the activity on the MFD. The system consists of an antenna located on top of the fuselage and a processor unit mounted under the aft baggage floor. The antenna detects the electrical and magnetic fields generated by intra-cloud, inter-cloud, or cloud to ground electrical discharges occurring within 200 nm of the airplane and sends the “discharge” data to the processor. The processor digitizes, analyzes, and converts the “discharge” signals into range and bearing data and communicates the data to the MFD every two seconds via the secondary Integrated Avionics Unit.

28 VDC for Weather System operation is supplied through the 5-amp WEATHER/DATA LINK circuit breaker on AVIONICS BUS. Refer to the Perspective Integrated Avionics System Pilot’s Guide for a general description of the system and its operating modes. If applicable, refer to the L-3 Stormscope WX-500 Weather Mapping Sensor Pilot’s Guide for a detailed discussion of the system.

### ***Bendix/King KR 87 Automatic Direction Finder (ADF)***

The KR 87 ADF System is used as a means of identifying positions, receiving low and medium frequency voice communications, homing, tracking, and for navigation on instrument approach procedures. The system consists of an antenna installed on the airplane exterior and the KR 87 receiver which communicates with the Integrated Avionics System via the secondary Integrated Avionics Unit. The HSI Bearing Needle may be configured to indicate ADF tracking and homing information. 28 VDC for ADF System operation is supplied through the 3-amp DME/ADF circuit breaker on AVIONICS BUS. Refer to the Perspective Integrated Avionics System Pilot’s Guide for a general description of the system and its operating modes. Refer to the Bendix/King ADF System Pilot’s Guide for a detailed discussion of the system.

### ***Bendix/King KN 63 Distance Measuring Equipment (DME)***

The KN 63 DME determines airplane distance to a land-based transponder by sending and receiving pulse pairs - two pulses of fixed duration and separation. The ground stations are typically collocated with VORs. The system consists of an antenna installed on the airplane exterior and the KN 63 receiver which communicates with the Integrated Avionics System via the secondary Integrated Avionics Unit. 28 VDC for ADF System operation is supplied through the 3-amp

DME/ADF circuit breaker on AVIONICS BUS. Refer to the Perspective Integrated Avionics System Pilot's Guide for a general description of the system and its operating modes. Refer to the Bendix/King DME System Pilot's Guide for a detailed discussion of the system.

### ***Synthetic Vision System***

The Synthetic Vision System (SVS) is intended to provide the pilot with enhanced situational awareness by placing a three dimensional depiction of terrain, obstacles, traffic and the desired flight path on the PFD so that proximity and location is more easily understood during instrument scanning. The SVS database is created from a digital elevation model with a 9 arc-sec (approx. 885 ft (270m)) horizontal resolution.

The synthetic vision system is not intended to be used independently of traditional attitude instrumentation. Consequently, SVS is disabled when traditional attitude instrumentation is not available. Otherwise, the traditional attitude instrumentation will always be visible in the foreground with SVS features in the background. The PFD with SVS installed includes:

- Perspective depiction of surrounding terrain,
- Zero pitch line,
- Perspective depiction of runways,
- Perspective depiction of large bodies of water,
- Perspective depiction of obstacles,
- Flight path marker,
- Terrain warning system,
- Field of view depiction on the MFD Navigation Page.

Refer to the Perspective Integrated Avionics System Pilot's Guide for a complete description of the system, its operating modes, and additional detailed operating procedures.

### ***Max Viz Enhanced Vision System***

The Enhanced Vision System is an electro-optical system that uses a Long-Wave Infrared (IR) camera. Infrared is particularly effective at night, smoke, haze, and smog in addition to a broad spectrum of rain, snow, and radiation-type fog. However, penetration is limited during certain environmental conditions associated with heavy rain, heavy snow, coastal fog and most cloud formations. Therefore the EVS is not intended for all atmospheric conditions and may only be used for acquisition of objects normally viewed through the cockpit windows. EVS is an aid to visual acquisitions of:

- Ground vehicles and other ground-based equipment/obstacles,
- Aircraft on taxi-ways and runways,
- Other traffic during takeoff, approach, and landing,
- Runway and taxi lights,
- Runway and terrain features during climb, descent, and low altitude maneuvering.

The EVS sensor, located on the underside of the LH wing, contains a long-wave infrared camera that produces a infrared image and a low-light CMOS camera that produces a visible image. The two images are then combined to produce a single fused image and transmitted directly to the MFD. Upon power-up the Sensor requires approximately 90 seconds to produce a usable image. The image generated is a monochrome image. The hotter an object is the whiter it appears on the display.

28 VDC Enhanced Vision System operation is supplied through the 5-amp EVS CAMERA circuit breaker on MAIN BUS 3. Refer to the Max Viz Enhanced Vision System Pilot's Guide for a detailed discussion of the system. For maintenance information and special precautions to be followed, refer to Section 8, [\*Enhanced Vision System Sensor Windows \(Optional\)\*](#).

### ***Approach Baro-VNAV***

While executing an LNAV/VNAV approach with SBAS unavailable, Baro-VNAV is used for vertical approach guidance. This occurs due to any of the following conditions:

- SBAS fails or becomes unavailable prior to final approach fix (FAF)
- the aircraft is outside SBAS coverage
- SBAS is manually disabled on the GPS Status page (To simulate a Baro-VNAV approach, SBAS must be manually disabled prior to activation of the approach procedure.)

Baro-VNAV is also the source of vertical approach guidance if the LNAV/VNAV procedure does not support SBAS vertical guidance.

While Baro-VNAV is being utilized, the Glidepath Indicator appears as a magenta pentagon. If the approach type downgrades past the FAF, “NO GP” is displayed in place of the pentagon.

While executing an LNAV/VNAV approach, between FAF and missed approach point (MAP), excessive deviation indicators appear as vertical yellow lines to indicate an area where the vertical deviation exceeds  $\pm 75$  feet.

#### Autopilot Interface

The GFC 700 Automatic Flight Control System uses the GP mode via the APR button to follow Approach Baro-VNAV guidance, as opposed to the VNAV mode via the VNV button. When coupled in GP mode, the GFC 700 will not capture a preselected altitude while tracking a Baro-VNAV glidepath.

#### Approach Downgrades

For approaches with minimums that support both SBAS and baro altitude vertical guidance, downgrading or reverting to barometric altitude guidance is allowed prior to 60 seconds before the FAF. If SBAS becomes unavailable after the approach is active but prior to 60 seconds before the FAF, an approach downgrade may be performed (e.g. LPV to LNAV/VNAV) or a vertical source reversion to baro altitude may be performed (e.g. SBAS LNAV/VNAV to baro LNAV/VNAV).

If a loss of SBAS occurs prior to 60 seconds before the FAF, the system will determine whether or not the approach mode can be supported using Baro-VNAV. If Baro-VNAV can be supported, the “APR ADVISORY - SBAS VNAV not available. Using Baro VNAV.”

message will be displayed on the PFDs and the vertical deviation indicator (VDI) will be flagged. If SBAS is required for the approach, the approach mode (e.g. LPV) will be shown in amber but the GPS/SBAS VDI will be displayed until 60 seconds prior to the FAF. If the SBAS integrity has not been restored at 60 seconds prior to the FAF, the system will display the “APR DWNGRADE - Apr downgraded. Baro VNAV.” message and flag the VDI.

Once the pilot acknowledges either message by viewing it on the PFD, the VDI will be restored using baro altitude vertical guidance instead of SBAS. There is no downgrade from SBAS to barometric altitude after the FAF or within 60 seconds of the FAF; “LNAV” is the only downgrade option in those cases. For approaches using barometric vertical guidance, downgrade is not allowed; if altitude or temperature data becomes invalid, the vertical deviation will be flagged.

#### Sensor Failures

The Outside Air Temperature (OAT) from the selected-side Air Data Computer will be used. If the OAT becomes invalid the VDI on that side will be flagged as invalid. The crew must select the off-side Air Data Computer sensor and VDI will return regardless of if prior to or after the FAF.

#### Sensor Comparison Annunciation

The temperature compensated altitudes from the pilot and co-pilot side are continuously compared. If a miscompare of greater than 50 feet is detected, the text “VDI MISCOMP” is displayed in the sensor comparison annunciation area on the PFD in black text with an amber background.

When a temperature-compensated altitude is not available for comparison, a “VDI NO COMP” annunciation is posted in comparison annunciation area on the PFD in black text with a white background.



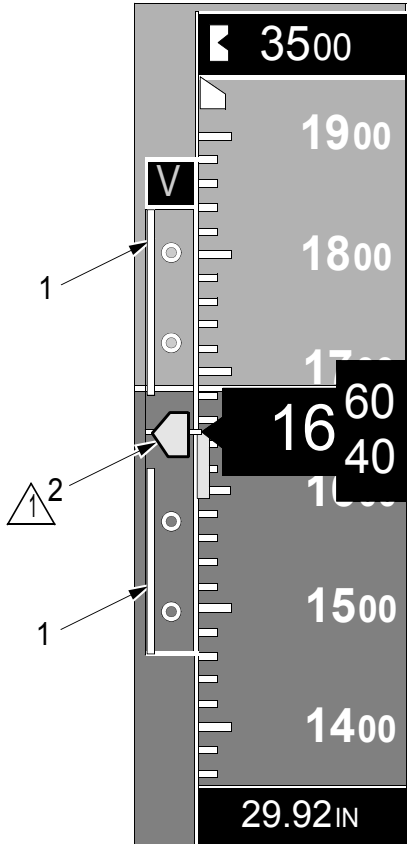

**NOTE**

 While Baro-VNAV is being utilized, the Glidepath Indicator appears as a magenta pentagon.

**LEGEND**

- 1.Excessive Deviation Indicator
- 2.Glidepath Indicator

SR22\_FM02\_3686

**Figure 7-19**  
**Baro-VNAV Vertical Deviation Indicator**

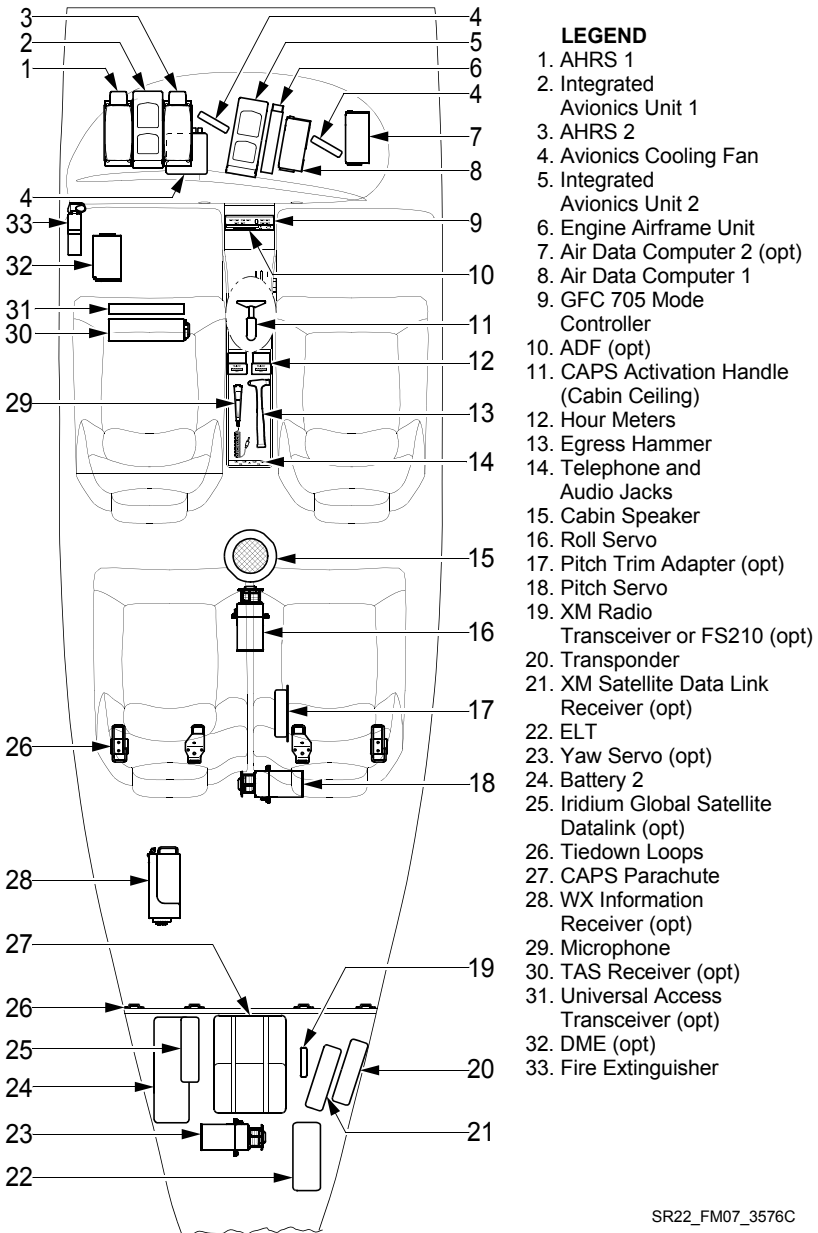

SR22\_FM07\_3576C

**Figure 7-20**  
**Equipment Locations**

## Avionics Support Equipment

### *Antennas*

Two rod-type COM antennas are mounted to the airplane's exterior; COM 1 is mounted directly above the passenger compartment, COM 2 is mounted directly below the baggage compartment. These antennas are connected to the two VHF communication transceivers contained in the Integrated Avionics Units.

The optional blade-type DME antenna is mounted on the airplane underside just aft, right of the firewall.

The optional combined loop/sense ADF antenna is mounted to the underside of the airplane just aft of the main wing spar. The antenna combines antenna signals into a single signal input to the ADF receiver.

A sled-type marker beacon antenna is mounted below the baggage compartment floor and provides a signal to the marker beacon receiver located in the audio panel. If the optional air conditioning system is installed this antenna is located below the baggage floor inside of the airplane.

The transponder antenna is located on the bottom side of the airplane, just aft of the baggage compartment bulkhead on the RH side of the airplane.

GPS 1 antenna is mounted directly above the passenger compartment. If the optional XM system is installed, a combination GPS 1/ XM antenna is installed in this location. A combination GPS 2 / Iridium antenna is mounted just forward of the baggage compartment window. These antennas are connected to the two GPS receivers contained in the Integrated Avionics Units.

The optional Traffic System antenna is mounted just above the pilot/ copilot compartment.

If the Avidyne TAS or Garmin GTS 800 Series TAS is installed, a second blade-type antenna is located on the bottom RH side of the airplane just forward of the baggage compartment.

The optional Lightning Detection antenna is mounted directly above the passenger compartment.

The Navigation antenna is mounted to the top of the vertical fin. This antenna provides VOR and glidescope signals to the VHF navigation receivers contained in the Integrated Avionics Units.

### ***Headset and Microphone Installation***

The airplane is equipped with provisions for five Active Noise Reduction (ANR) and three conventional (MIC/HEADPHONES) headsets. Headset jacks for the pilot, front, and rear seat passenger are located in the map case.

The forward headset mics use the remote Push-To-Talk (PTT) switches located on the top of the associated control yoke grip. The rear headsets do not have COM transmit capabilities and do not require PTT switches. Audio to headsets is controlled by the individual audio selector switches on the audio control panel

### ***Audio Input Jack***

The aircraft contains multiple audio input jacks which can be used to connect personal entertainment devices into the cabin sound system. Two 3.5 mm audio input jacks (AUDIO INPUT) are provided on the center console. One jack is located near the convenience outlet for use by the pilot and forward passenger, and the other is located on the aft portion of the center console for the rear passengers.

Distribution of a device connected to the forward jack is through the MUS 1 selection on the audio panel. Distribution of the rear jack is by the MUS 2 selection on the audio panel. A third jack on the audio panel will also accept an entertainment input. A device connected to this jack is distributed by selecting the *Entertainment button* (shown as a phone and music-note symbol) on the audio panel. Audio volume can be controlled by the device itself and can be further refined by the audio panel distribution volume control.

### ***Cell Phone Input Jack***

One 2.5 mm cell phone jack is located on the front of the audio panel and is distributed by selecting the *Entertainment button* (shown as a phone and music-note symbol) on the audio panel. Volume is controlled by the volume selector on the audio panel

### ***Avionics Cooling Fans***

Electric fans provide forced ambient-air cooling for the Integrated Avionics System. A fan located forward of the instrument panel provides ambient air cooling directly to the Integrated Avionics Units. Two additional fans blow air directly onto the heat sinks located on the forward sides of the PFD and MFD.

28 VDC for MFD Fan operation is supplied through the 5-amp AVIONICS FAN 1 circuit breaker on NON-ESSENTIAL BUS. 28 VDC for PFD and Integrated Avionics Unit Fan operation is supplied through the 5-amp AVIONICS FAN 2 circuit breaker on MAIN BUS 2.

## Cabin Features

### Emergency Locator Transmitter

The airplane is equipped with a self-contained emergency locator transmitter (ELT). The transmitter and antenna are installed immediately behind the aft cabin bulkhead, slightly to the right of the airplane centerline. The main transmitter control switch, labeled ON-OFF-ARMED, on the transmitter is in the armed position for normal operations. A remote switch and indicator panel is installed on the left console near the pilot's right knee. If rapid deceleration is detected, the transmitter will repeatedly transmit VHF band audio sweeps at 121.5 MHz and 243.0 MHz approximately 0.5 seconds apart.

The transmitter and antenna are accessible through the avionics bay access panel along the aft portion of the RH fuselage or the lower aft center access panel of baggage compartment. The ELT can be removed from the airplane and used as a personal locating device if it is necessary to leave the airplane after an accident. Eight dated "D" cell alkaline batteries contained within the transmitter unit power the ELT transmitter. The batteries must be replaced at specified intervals based upon the date appearing on the battery (Refer to Airplane Maintenance Manual).

#### ***ELT Remote Switch and Indicator Panel***

The ELT remote switch and indicator panel, located on the left console near the pilot's right knee, provides test and monitoring functions for the ELT. The panel contains a button labeled ON, a button labeled RESET, and a red LED (light). The red light flashes when the ELT is transmitting. The ON button is used to test the unit in accordance with the maintenance manual procedures. The RESET button can be used to cancel an inadvertent transmission. A 6-volt Lithium battery mounted in the panel powers the LED. The battery must be replaced at regular intervals (Refer to Airplane Maintenance Manual).

In the event of an accident:

1. Verify ELT operation by noting that the ELT indicator light on the remote panel is flashing.
2. If possible, access the unit as described below and set the ELT main transmitter control switch ON.

Portable use of ELT:

- a. Remove access at lower aft center of baggage compartment.

- b. Disconnect fixed antenna lead from front of unit.
- c. Disconnect lead from remote switch and indicator unit.
- d. Loosen attach straps and remove transmitter unit and portable antenna.
- e. Attach portable antenna to antenna jack on front of unit.
- f. Set main control switch to ON.
- g. Hold antenna upright as much as possible.

## Fire Extinguisher

A liquefied-gas-type fire extinguisher, mounted on the forward outboard side of the pilot-side footwell, contains Halon 1211/1301 extinguishing agent (*Serials w/o gaged fire extinguisher*), or Halon 1211 extinguishing agent (*Serials w/ gaged fire extinguisher*).

The extinguisher is approved for use on class B (liquid, grease) and class C (electrical equipment) fires. A pin is installed through the discharge mechanism to prevent inadvertent discharge of extinguishing agent.

*Serials w/o gaged fire extinguisher:* The fire extinguisher must be replaced after each use.

*Serials w/ gaged fire extinguisher:* The fire extinguisher must be recharged or replaced after each use.

To operate the extinguisher:

1. Loosen retaining clamp and remove the extinguisher from its mounting bracket.
2. Hold the extinguisher upright and pull the pin.
3. Get back from the fire and aim nozzle at base of fire at the nearest edge.
4. Press red lever and sweep side to side.

### • **WARNING** •

Halon gas used in the fire extinguisher can be toxic, especially in a closed area. After discharging fire extinguisher, ventilate cabin by opening air vents and unlatching door. Close vents and door after fumes clear.

The extinguisher must be inspected before each flight to ensure that it is available, charged, and operable. The preflight inspection consists

of ensuring that the nozzle is unobstructed, the pin has not been pulled, and the canister has not been damaged.

*Serials w/o gaged fire extinguisher:* The unit should weigh approximately 1.5 lb (0.7 kg). For preflight, charge can be determined by 'hefting' the unit.

*Serials w/ gaged fire extinguisher:* The unit should weigh approximately 2.5 lb (1.1 kg). For preflight, charge can be determined by verifying the gage pressure is in the operable (green) range, or by 'hefting' the unit.

## Hour Meters

The airplane is equipped with two hour meters located inside the armrest storage compartment between the pilot and copilot seats. The #1 hour meter, labeled HOBBS begins recording when the BAT 1 switch is ON and either the ALT 1 or ALT 2 switch is ON. The #2 hour meter records flight time and is labeled FLIGHT. Recording begins when the airplane reaches a speed of approximately 35 KIAS and is controlled by the Integrated Avionics Unit.

28 VDC for hour meter operation is supplied through the 5-amp FUEL QTY circuit breaker on MAIN BUS 1.

## Emergency Egress Hammer

An eight-ounce ball-peen type hammer is located in the center armrest accessible to either front seat occupant. In the event of a mishap where the cabin doors are jammed or inoperable, the hammer may be used to break through the acrylic windows to provide an escape path for the cabin occupants.

## Convenience Outlet(s)

A 12-volt convenience outlet is installed in the center console. The receptacle accepts a standard cigarette-lighter plug. The outlet may be used to power portable entertainment equipment such as CD players and portable radios. Amperage draw through the outlet must not exceed 3.5 amps. Power for the convenience outlet is supplied through the 5-amp 12V DC OUTLET circuit breaker on the MAIN BUS 3.

*Serials 0954, 0963 & subs:* Four Universal Serial Bus-A (USB-A) high-power dedicated charging ports are installed in the center console. Two ports are located near the 12-volt convenience outlet for use by the pilot and forward passenger, and two ports are located on the aft portion of the center console for use by the rear passengers. The ports



comply with USB Battery Charging 1.2 Compliance Plan, and are intended for USB-compatible devices only. There is no data or audio access at the ports. Amperage draw through the each USB charging port must not exceed 2.1 amps. Power for the USB ports is supplied through the 5-amp 12V DC OUTLET circuit breaker on the MAIN BUS 3.

## Cirrus Airframe Parachute System

The airplane is equipped with a Cirrus Airframe Parachute System (CAPS) designed to bring the airplane and its occupants to the ground in the event of a life-threatening emergency. The system is intended to save the lives of the occupants but will most likely destroy the airplane and may, in adverse circumstances, cause serious injury or death to the occupants. Because of this it is important to carefully read Section 3 - Emergency Procedures, *CAPS Deployment Checklist* and Section 10 - Safety Information, *Cirrus Airframe Parachute System (CAPS)* to consider when and how you would use the system.

### • WARNING •

The parachute system can be activated at any time. The solid-propellant rocket flight path is upward from the parachute cover. Stay clear of parachute canister area when airplane is occupied. Do not allow children in the airplane unattended.

## System Description

The CAPS consists of a parachute, a solid-propellant rocket to deploy the parachute, a rocket activation handle, and a harness imbedded within the fuselage structure.

A composite box containing the parachute and solid-propellant rocket is mounted to the airplane structure immediately aft of the baggage compartment bulkhead. The box is covered and protected from the elements by a thin composite cover.

The parachute is enclosed within a deployment bag that stages the deployment and inflation sequence. The deployment bag creates an orderly deployment process by allowing the canopy to inflate only after the rocket motor has pulled the parachute lines taut.

The parachute itself is a round canopy equipped with a slider, an annular-shaped fabric panel with a diameter significantly less than the open diameter of the canopy. The slider has grommets spaced around its perimeter. The canopy suspension lines are routed through these grommets so that the slider is free to move along the suspension lines. Since the slider is positioned at the top of the suspension lines near the canopy, at the beginning of the deployment sequence the slider limits the initial diameter of the parachute and the rate at which the parachute inflates. As the slider moves down the suspension lines the canopy inflates.

A three-point harness connects the airplane fuselage structure to the parachute. The aft harness strap is stowed in the parachute canister and attached to the structure at the aft baggage compartment bulkhead. The forward harness straps are routed from the canister to firewall attach points just under the surface of the fuselage skin. When the parachute deploys, the forward harness straps pull through the fuselage skin covering from the canister to the forward attach points.

## Activation Handle

CAPS is initiated by pulling the CAPS Activation T-handle installed in the cabin ceiling on the airplane centerline just above the pilot's right shoulder. A placarded cover, held in place with hook and loop fasteners, covers the T-handle and prevents tampering with the control. The cover is to be removed by pulling the black tab at the forward edge of the cover.

Pulling the activation T-handle will activate the rocket and initiate the CAPS deployment sequence. To activate the rocket, two separate events must occur:

1. Pull the activation T-handle from its receptacle. Pulling the T-handle removes it from the o-ring seal that holds it in place and takes out the slack in the cable (approximately two inches (5 cm) of cable will be exposed). Once the slack is removed, the T-handle motion will stop and greater force will be required to activate the rocket.
2. Clasp both hands around activation T-handle and pull straight downward with a strong, steady, and continuous force until the rocket activates. A chin-up type pull works best. Up to 45.0 pounds (20.4 Kg) force, or greater, may be required to activate the rocket. The greater force required occurs as the cable arms and then releases the igniter switch plunger activating the electronic igniter.

• Note •

Jerking or rapidly pulling on the activation T-handle greatly increases the pull forces required to activate the rocket.

Attempting to activate the rocket by pushing the activation T-handle forward and down limits the force that can be applied. Pulling the activation T-handle straight down generates the greatest force.

A maintenance safety pin is provided to ensure that the activation handle is not pulled during maintenance. However, there may be some circumstances where an operator may wish to safety the CAPS system; for example, the presence of unattended children in the airplane, the presence of people who are not familiar with the CAPS activation system in the airplane, or during display of the airplane.

The pin is inserted through the handle retainer and barrel locking the handle in the "safe" position. A "Remove Before Flight" streamer is attached to the pin.

• **WARNING** •

After maintenance has been performed or any other time the system has been safetied, operators must verify that the pin has been removed before further flight.

## Deployment Characteristics

When the rocket launches, the parachute assembly is extracted outward due to rocket thrust and rearward due to relative wind. In approximately two seconds the parachute will begin to inflate.

When air begins to fill the canopy, forward motion of the airplane will dramatically be slowed. This deceleration increases with airspeed but in all cases within the parachute envelope should be less than 3 g's. During this deceleration a slight nose-up may be experienced, particularly at high speed; however, the rear riser is intentionally snubbed short to preclude excessive nose-up pitch. Following any nose-up pitching, the nose will gradually drop until the airplane is hanging nose-low beneath the canopy.

Eight seconds after deployment, the rear riser snub line will be cut and the airplane tail will drop down into its final approximately level attitude. Once stabilized in this attitude, the airplane may yaw slowly back and forth or oscillate slightly as it hangs from the parachute. Descent rate is expected to be less than 1700 feet per minute with a lateral speed equal to the velocity of the surface wind. In addition, surface winds may continue to drag the airplane after ground impact.

• **Caution** •

Ground impact is expected to be equivalent to touchdown from a height of approximately 13 feet. While the airframe, seats and landing gear are designed to accommodate this stress, occupants must prepare for it in accordance with Section 3 - *CAPS Deployment* Checklist.

• **Note** •

The CAPS is designed to work in a variety of airplane attitudes, including spins. However, deployment in an attitude other than level flight may yield deployment characteristics other than those described above.

Intentionally Left Blank

# ***Section 8: Handling and Servicing***

## **Table of Contents**

Introduction .....	3
Operator's Publications .....	3
Service Publications .....	3
Obtaining Publications .....	4
Airplane Records and Certificates .....	5
Airworthiness Directives .....	6
Airplane Inspection Periods .....	6
Annual Inspection .....	6
100-Hour Inspection .....	7
Cirrus Design Progressive Inspection Program .....	7
Pilot Performed Preventative Maintenance .....	8
Ground Handling .....	10
Application of External Power .....	10
Towing .....	11
Taxiing .....	12
Parking .....	13
Tiedown .....	14
Leveling .....	14
Jacking .....	14
Servicing .....	16
Landing Gear Servicing .....	16
Brake Servicing .....	16
Tire Inflation .....	17
Propeller Servicing .....	17
Oil Servicing .....	19
Fuel System Servicing .....	21
Battery Service .....	23
Oxygen System Servicing .....	24
Key Fob Battery Replacement .....	24
Cleaning and Care .....	25
Cleaning Exterior Surfaces .....	25
Care of Graphics .....	27
Cleaning Interior Surfaces .....	34

Intentionally Left Blank



# Section 8 - Handling, Servicing, and Maintenance

## Servicing

### Landing Gear Servicing

*Serials w/ tubeless tire:*

The main landing gear wheel assemblies use 15 x 6.00 x 6 tubeless tires. The nose wheel assembly uses a 5.00 x 5 tubeless tire.

### Brake Servicing

#### ***Brake Replenishing***

*Serials w/ Beringer Brake System:*

The brake system is filled with MIL-PRF-87257 hydraulic brake fluid.

To replenish brake fluid:

1. Chock tires and release parking brake.
2. Remove top engine cowling to gain access to hydraulic fluid reservoir.
3. Clean reservoir cap and area around cap before opening reservoir cap.
4. Remove cap and add MIL-PRF-87257 hydraulic fluid as necessary to fill reservoir.
5. Install cap, inspect area for leaks, and then install and secure engine cowling.

## Tire Inflation

To inflate tires:

1. Remove inspection buttons on wheel pants to gain access to valve stems. It may be necessary to move airplane to get valve stem aligned with the access hole.
2. Remove valve stem cap and verify tire pressure with a dial-type tire pressure gage.

**• Caution •**

The LH and RH main wheel tire pressures must be within 20 psi of each other to ensure the load is evenly distributed between the main wheels.

3. Inflate nose tire to 30 - 35 psi (207 - 241 kPa) and main wheel tires to 60 - 65 psi (414 - 448 kPa).
4. Replace valve stem cap and inspection buttons.

## Introduction

This section provides general guidelines for handling, servicing and maintaining your aircraft. In order to ensure continued safe and efficient operation of your airplane, keep in contact with your Authorized Cirrus Service Center to obtain the latest information pertaining to your aircraft.

## Operator's Publications

The FAA Approved Airplane Flight Manual and Pilot's Operating Handbook (POH) is provided at delivery. Additional or replacement copies may be obtained from Cirrus Design.

## Service Publications

The following service publications are available for purchase from Cirrus Design:

- Airplane Maintenance Manual (AMM) – Maintenance Manual divided into chapters as specified by GAMA and ATA covering inspection, servicing, maintenance, troubleshooting, and repair of the airplane structure, systems, and wiring. Revision Service for this manual is also available. A current copy of the AMM is provided at delivery.
- Engine Operators and Maintenance Manual – Cirrus Design provides a Teledyne Continental Engine Operator's and Maintenance Manual at the time of delivery. Engine and engine accessory overhaul manuals can be obtained from the original equipment manufacturer.
- Avionics Component Operator and Maintenance Manuals — Cirrus Design provides all available operator's manuals at the time of delivery. Maintenance manuals, if available, may be obtained from the original equipment manufacturer.

Cirrus Design publishes Service Bulletins, Service Advisories, and Service Information Letters. Copies can be obtained from Cirrus Design at [www.cirrusaircraft.com](http://www.cirrusaircraft.com).

- Service Bulletins – are of special importance. When a Service Bulletin is published affecting your airplane, comply with it promptly.
- Service Advisories – are used to notify you of optional Service Bulletins, supplier Service Bulletins or Service Information

Letters affecting your airplane, and maintenance data or corrections not requiring a Service Bulletin. Give careful attention to the Service Advisory information.

## **Obtaining Publications**

Pilot's Operating Handbooks and aircraft service publications can be obtained from Cirrus Design at [www.cirrusaircraft.com](http://www.cirrusaircraft.com), or the Cirrus Connection at [www.cirrusconnection.com](http://www.cirrusconnection.com).

## Airplane Records and Certificates

The Federal Aviation Administration (FAA) requires that certain data, certificates, and licenses be displayed or carried aboard the airplane at all times. Additionally, other documents must be made available upon request. The mnemonic acronym “ARROW” is often used to help remember the required documents.

• Note •

Owners of aircraft not registered in the United States should check with the registering authority for additional requirements.

Required Documents		Note
<b>A</b>	Airworthiness Certificate FAA Form 8100-2	Must be displayed at all times.
<b>R</b>	Registration Certificate FAA Form 8050-3	Must be in the aircraft for all operations.
<b>R</b>	Radio Station License FCC Form 556	Required only for flight operations outside the United States.
<b>O</b>	Operating Instructions	FAA Approved Flight Manual and Pilot's Operating Handbook fulfills this requirement.
<b>W</b>	Weight & Balance Data	Included in FAA Approved Airplane Flight Manual and Pilot's Operating Handbook. Data must include current empty weight, CG, and equipment list.

Other Documents		Note
	Airplane Logbook	Must be made available upon request.
	Engine Logbook	Must be made available upon request.
	Pilot's Checklist	Available in cockpit at all times.

## Airworthiness Directives

The Federal Aviation Administration (FAA) publishes Airworthiness Directives (AD's) that apply to specific aircraft and aircraft appliances or accessories. AD's are mandatory changes and must be complied with within a time limit set forth in the AD. Operators should periodically check with Cirrus Service Centers or A&P mechanic to verify receipt of the latest issued AD for their airplane.

## Airplane Inspection Periods

• Note •

FAR 1.1 defines time in service, with respect to maintenance time records, as "the time from the moment an aircraft leaves the surface of the earth until it touches it at the next point of landing."

The #2 Hour Meter, located in the center console and labeled FLIGHT, begins recording when the airplane reaches approximately 35 KIAS and should be used to track maintenance time intervals as it more accurately records time in service than the #1 Hour Meter.

The inspection items specified in the Annual/100 Inspection have been determined by the average aircraft use rate of the typical owner. Non-commercially operated aircraft that are flown significantly more than 100 hours per year should consider additional inspections commensurate with the hours flown. 100-Hour Inspection or enrollment in a Progressive Inspection Program should be considered in addition to the normally required Annual Inspection. The Annual Inspection interval may also be shortened to accommodate high utilization rate.

## Annual Inspection

Unless enrolled in a Progressive Inspection Program, The U.S. Federal Aviation Regulations require all civil aircraft must undergo a thorough Annual Inspection every twelve calendar months. Annual Inspections are due on the last day of the twelfth month following the last Annual Inspection. For example: If an Annual Inspection was performed on 19 November 2010, the next Annual Inspection will be due 30 November 2011. Annual Inspections must be accomplished regardless of the number of hours flown the previous year and can

only be performed by a licensed Airframe and Powerplant (A&P) mechanic holding an Inspection Authorization (IA). All Cirrus Authorized Service Centers can perform Annual Inspections. The inspection is listed, in detail, in Chapter 5 of the Aircraft Maintenance Manual.

## **100-Hour Inspection**

If the airplane is used commercially, in addition to the Annual Inspection requirement, the Federal Aviation Regulations require that the airplane undergo a 100-Hour Inspection every 100 hours of flight operation. The scope of the 100-Hour Inspection is identical to the Annual Inspection except that it can be accomplished by a licensed A&P mechanic. The 100-hour interval may be exceeded by not more than 10 flight hours in order to reach a place where the inspection can be accomplished. Any flight hours used to reach an inspection station must be deducted from the next 100-Hour Inspection interval. The inspection is listed, in detail, in Chapter 5 of the Aircraft Maintenance Manual.

## **Cirrus Design Progressive Inspection Program**

In lieu of the above requirements, an airplane may be inspected using a Progressive Inspection Program in accordance with the Federal Aviation Regulation Part 91.409.

The Cirrus Design Progressive Inspection Program provides for the complete inspection of the airplane utilizing a five-phase cyclic inspection program.

*400 flight hours:* A total of eight inspections are accomplished over the course of 400 flight hours, with an inspection occurring every 50 flight hours.

*800 flight hours:* A total of sixteen inspections are accomplished over the course of 800 flight hours, with an inspection occurring every 50 flight hours.

The inspection items to be covered in the Progressive Inspection are very similar to the Annual Inspection items. The Progressive Inspection will accomplish a full Inspection of the airplane at 400 (or 800) flight hours or at 12 calendar months.

The inspections are listed, in detail, in Chapter 5 of the Aircraft Maintenance Manual.

## Pilot Performed Preventative Maintenance

The holder of a Pilot Certificate issued under FAR Part 61 may perform certain preventive maintenance described in FAR Part 43, Appendix A. This maintenance may be performed only on an aircraft that the pilot owns or operates and which is not used in air carrier service. The regulation also stipulates that the pilot must also complete the appropriate logbook entries. The following is a list of the maintenance that the pilot may perform:

• Note •

The pilot should have the ability and manual procedures for the work to be accomplished.

The pilot may not accomplish any work involving the removal or disassembly of primary structure or operating system, or interfere with an operating system, or affect the primary structure.

- Remove, install, and repair tires.
- Clean, grease, or replace wheel bearings.
- Replace defective safety wire or cotter pins.
- Lubrication not requiring disassembly other than removal of non-structural items such as access covers, cowlings, or fairings.

• Caution •

Do not use unapproved lubricants. Unapproved lubricants may damage control system components, including but not limited to engine and flight controls. Refer to the AMM for approved lubricants.

- Replenish hydraulic fluid in the hydraulic and brake reservoirs.
- Refinish the airplane interior or exterior (excluding balanced control surfaces) with protective coatings.
- Repair interior upholstery and furnishings.
- Replace side windows.
- Replace bulbs, reflectors and lenses of position and landing lights.
- Replace cowling not requiring removal of the propeller.
- Replace, clean or set spark plug gap clearance.



- Replace any hose connection, except hydraulic connections, with replacement hoses.
- Clean or replace fuel and oil strainers, as well as replace or clean filter elements.
- Replace prefabricated fuel lines.
- Replace the battery and check fluid level and specific gravity.

### ***Logbook Entry***

After any of the above work is accomplished, appropriate logbook entries must be made. Logbook entries should contain:

- The date the work was accomplished.
- Description of the work.
- Number of hours on the aircraft.
- The certificate number of pilot performing the work.
- Signature of the individual doing the work.

Logbooks should be complete and up to date. Good records reduce maintenance cost by giving the mechanic information about what has or has not been accomplished.

## Ground Handling

### Application of External Power

A ground service receptacle, located just aft of the cowl on the left side of the airplane, permits the use of an external power source for cold weather starting and maintenance procedures.

#### • WARNING •

If external power will be used to start engine, keep yourself, others, and power unit cables well clear of the propeller rotation plane.

#### *To apply external power to the airplane:*

##### • Caution •

Do not use external power to start the airplane with a 'dead' battery or to charge a dead or weak battery in the airplane. The battery must be removed from the airplane and battery maintenance performed in accordance with the appropriate AMM procedures.

1. Ensure that external power source is regulated to 28 VDC.
2. Check BAT and AVIONICS power switches are 'off.'
3. Plug external power source into the receptacle.
4. Set BAT 1 switch to ON. 28 VDC from the external power unit will energize the main distribution and essential distribution buses. The airplane may now be started or electrical equipment operated.
5. If avionics are required, set AVIONICS power switch ON.

##### • Caution •

If maintenance on avionics systems is to be performed, it is recommended that external power be used. Do not start or crank the engine with the AVIONICS power switch 'on.'

#### *To remove external power from airplane:*

1. If battery power is no longer required, set BAT 1 switch 'off.'
2. Pull external power source plug.

## Towing

The airplane may be moved on the ground by the use of the nose wheel steering bar that is stowed in the rear baggage compartment or by power equipment that will not damage or excessively strain the nose gear assembly. The steering bar is engaged by inserting it into lugs just forward of the nose wheel axle.

### • Caution •

While pushing the aircraft backward, the tow bar must be installed to keep the nose wheel from turning abruptly.

Do not use the vertical or horizontal control surfaces or stabilizers to move the airplane. If a tow bar is not available, use the wing roots as push points.

Do not push or pull on control surfaces or propeller to maneuver the airplane.

Do not tow the airplane when the main gear is obstructed with mud or snow.

If the airplane is to be towed by vehicle, do not turn the nose wheel more than 90 degrees either side of center or structural damage to the nose gear could result.

1. Refer to Section 1, *Airplane Three View* for turning radius clearances. Be especially cognizant of hangar door clearances.
2. Insert tow bar into the lugs just forward of the nose wheel axle.
3. Release parking brake and remove chocks.
4. Move airplane to desired location.
5. Install chocks.
6. Remove tow bar.

To obtain a minimum radius turn during ground handling, the airplane may be rotated around either main landing gear by pressing down on the fuselage just forward of the horizontal stabilizer to raise the nose wheel off the ground.

## Taxiing

Before attempting to taxi the airplane, ground personnel should be instructed and authorized by the owner to taxi the airplane. Instruction should include engine starting and shutdown procedures in addition to taxi and steering techniques.

### • Caution •

Verify that taxi and propeller wash areas are clear before beginning taxi.

Do not operate the engine at high RPM when running up or taxiing over ground containing loose stones, gravel, or any loose material that may cause damage to the propeller blades.

Taxi with minimum power needed for forward movement. Excessive braking may result in overheated or damaged brakes.

1. Remove chocks.
2. Start engine in accordance with Starting Engine procedure.
3. Release parking brake.
4. Advance throttle to initiate taxi. Immediately after initiating taxi, apply the brakes to determine their effectiveness. During taxiing, use differential braking to make slight turns to ascertain steering effectiveness.

### • Caution •

Observe wing clearance when taxiing near buildings or other stationary objects. If possible, station an observer outside the airplane.

Avoid holes and ruts when taxiing over uneven ground.

5. Taxi airplane to desired location.
6. Shut down airplane and install chocks and tie-downs in accordance with Shutdown procedure.

## Parking

The airplane should be parked to protect the airplane from weather and to prevent it from becoming a hazard to other aircraft. The parking brake may release or exert excessive pressure because of heat buildup after heavy braking or during wide temperature swings. Therefore, if the airplane is to be left unattended or is to be left overnight, chock and tie down the airplane.

1. For parking, head airplane into the wind if possible.
2. Retract flaps.
3. Set parking brake by first applying brake pressure using the toe brakes and then pulling the PARK BRAKE knob aft.

### • Caution •

Care should be taken when setting overheated brakes or during cold weather when accumulated moisture may freeze a brake.

4. Chock both main gear wheels.
5. Tie down airplane in accordance with tiedown procedure in this section.
6. Install a Pitot head cover. Be sure to remove the Pitot head cover before flight.
7. Cabin and baggage doors should be locked when the airplane is unattended.

## Tiedown

The airplane should be moored for immovability, security and protection. FAA Advisory Circular AC 20-35C, Tiedown Sense, contains additional information regarding preparation for severe weather, tiedown, and related information. The following procedures should be used for the proper mooring of the airplane:

1. Head the airplane into the wind if possible.
2. Retract the flaps.
3. Chock the wheels.
4. Secure tie-down ropes to the wing tie-down rings and to the tail ring at approximately 45-degree angles to the ground. When using rope or non-synthetic material, leave sufficient slack to avoid damage to the airplane should the ropes contract.

### • Caution •

Anchor points for wing tiedowns should not be more than 18 feet apart to prevent eyebolt damage in heavy winds.

Use bowline knots, square knots, or locked slipknots. Do not use plain slipknots.

## Leveling

The airplane is leveled longitudinally by means of a spirit level placed on the pilot door sill and laterally by means of a spirit level placed across the door sills. Alternately, sight the forward and aft tool holes along waterline 95.9 to level airplane. Refer to AMM Section 6, Airplane Weighing Procedures for illustration.

## Jacking

Three jacking points, located at each wing tiedown and tail tiedown, are provided to perform maintenance operations. Tie-down rings must be removed and replaced with jack points prior to lifting. Jack points are stowed in the baggage compartment. The airplane may be jacked using two standard aircraft hydraulic jacks at the wing jacking points and a weighted tailstand attached to the aft tail tiedown. Refer to AMM Section 7, Airplane Lifting Procedures for list of required tools and for illustration.

## ***Raise Airplane***

### **• Caution •**

Do not jack the aircraft outside or in open hangar with winds in excess of 10 mph.

The empty CG is forward of the wing jacking points. To prevent airplane from tipping forward during maintenance or jacking, use a weighted tailstand (300-lb minimum) attached to the tail tiedown.

Jacks must be used in pairs. Do not attempt to jack only one side of aircraft. Keep the airplane as level as possible when jacking.

1. Position airplane on a hard, flat, level surface.
2. Remove main gear fairings. (Refer to AMM 32-10)
3. Remove and stow tie-down rings from wings.
4. Attach a weighted tailstand to tail tiedown ring.
5. Position jacks and jack points for jacking. Insert jack point into wing tiedown receptacle. Holding the jack point in place, position the jack under the point and raise the jack to firmly contact the jack point. Repeat for opposite jacking point.
6. Raise airplane no more than required for maintenance being performed.
7. Raise the airplane keeping the airplane as level as possible.
8. Secure jack locks.

## ***Lower Airplane***

1. Release pressure on all jacks simultaneously to keep airplane as level as possible.
2. Remove jacks, jack points, and tailstand. Stow points in baggage compartment.
3. Install tiedown rings.
4. Install main gear fairings. (Refer to AMM 32-10)

## Servicing

### Landing Gear Servicing

*Serials 0442 thru 0656, 0658 thru 0689 before SB2X-32-21:* The main landing gear wheel assemblies use 15 x 6.00 x 6 tires and tubes. The nose wheel assembly uses a 5.00 x 5 tire and tube.

*Serials 0442 thru 0656, 0658 thru 0689 after SB2X-32-21, 0657, 0690 & subs:* The main landing gear wheel assemblies use 15 x 6.00 x 6 tubeless tires. The nose wheel assembly uses a 5.00 x 5 tubeless tire.

*All Serials:* Always keep tires inflated to the rated pressure to obtain optimum performance and maximum service. The landing gear struts do not require servicing. With the exception of replenishing brake fluid, wheel and brake servicing must be accomplished in accordance with AMM procedures.

### Brake Servicing

#### ***Brake Replenishing***

*Serials 0442 thru 0656, 0658 thru 0689 before SB2X-32-21:* The brake system is filled with MIL-H-5606 hydraulic brake fluid.

*Serials 0442 thru 0656, 0658 thru 0689 after SB2X-32-21, 0657, 0690 & subs:* The brake system is filled with MIL-PRF-87257 hydraulic brake fluid.

*All Serials:* The fluid level should be checked at every oil change and at the annual/100-hour inspection, replenishing the system when necessary. The brake reservoir is located on the right side of the battery support frame. If the entire system must be refilled, refer to the AMM.

To replenish brake fluid:

1. Chock tires and release parking brake.
2. Remove top engine cowling to gain access to hydraulic fluid reservoir.
3. Clean reservoir cap and area around cap before opening reservoir cap.
4. Remove cap and add appropriate hydraulic fluid as necessary to fill reservoir.
5. Install cap, inspect area for leaks, and then install and secure engine cowling.



## Tire Inflation

For maximum service from the tires, keep them inflated to the proper pressure. When checking tire pressure, examine the tires for wear, cuts, nicks, bruises and excessive wear.

To inflate tires:

1. Remove inspection buttons on wheel pants to gain access to valve stems. It may be necessary to move airplane to get valve stem aligned with the access hole.
2. Remove valve stem cap and verify tire pressure with a dial-type tire pressure gage.
3. *Serials 0442 thru 0656, 0658 thru 0689 before SB2X-32-21:* Inflate nose tire to 40+/-2 psi (276 kPa) and main wheel tires to 62+2/-0 psi (427 kPa).

### • Caution •

*Serials 0442 thru 0656, 0658 thru 0689 after SB2X-32-21, 0657, 0690 & subs:* The LH and RH main wheel tire pressures must be within 20 psi of each other to ensure the load is evenly distributed between the main wheels.

4. *Serials 0442 thru 0656, 0658 thru 0689 after SB2X-32-21, 0657, 0690 & subs:* Inflate nose tire to 40 - 90 psi (276 - 621 kPa) and main wheel tires to 62 - 112 psi (427 - 772 kPa).
5. Replace valve stem cap and inspection buttons.

All wheels and tires are balanced before original installation and the relationship of tire, tube, and wheel should be maintained upon reinstallation. In the installation of new components, it may be necessary to rebalance the wheels with the tires mounted. Unbalanced wheels can cause extreme vibration in the landing gear.

## Propeller Servicing

The spinner and backing plate should be cleaned and inspected for cracks frequently. Before each flight the propeller should be inspected for nicks, scratches, and gouges. If found, they should be repaired as soon as possible by a rated mechanic, since a nick or scratch causes an area of increased stress which can lead to serious cracks or the loss of a propeller tip.

Propeller blades are painted with a durable specialized coating that is resistant to abrasion. If this coating becomes eroded, it is necessary to

repaint the blades to provide proper erosion protection. Painting should be performed by an authorized propeller repair station.

It is permissible to perform a blade touch-up with aerosol paint in accordance with the appropriate revision of the Hartzell Propeller Owner's Manual (p/n 145).

## Oil Servicing

The oil capacity of the Teledyne Continental IO-550-K engine is 8 quarts. It is recommended that the oil be changed every 50 hours and sooner under unfavorable operating conditions. The following grades are recommended for the specified temperatures at sea level (SL):

Ambient Air Temperature (SL)	Single Viscosity	Multi-Viscosity
All Temperatures	—	20W-60 20W-50 15W-50
Below 40°F	SAE 30	10W-30 20W-60 20W-50 15W-50
Above 40°F	SAE 50	20W-60 20W-50 15W-50

An oil filler cap and dipstick are located at the left rear of the engine and are accessible through an access door on the top left side of the engine cowling.

• Caution •

The engine should not be operated with less than six quarts of oil. Seven quarts (dipstick indication) is recommended for extended flights.

To check and add oil:

1. Open access door on upper left-hand side of cowl. Pull dipstick and verify oil level.
2. If oil level is below 6 quarts (5.7 liters), remove filler cap and add oil through filler as required to reach 6-8 quarts (5.7-7.6 liters).
3. Verify oil level and install dipstick and filler cap.
4. Close and secure access panel.

### Approved Oils

*Engine Break-In:* For first 25 hours of operation or until oil consumption stabilizes use straight mineral oil conforming to MIL-C-6529. If engine oil must be added to the factory installed oil, add only MIL-C-6529 straight mineral oil.

*After Engine Break-In:* Use only oils conforming to Teledyne Continental Specification SAE J 1899 (Ashless Dispersant Lubrication Oil).

<b>Product</b>	<b>Supplier</b>
Aeroshell (R) W	Shell Australia
Aeroshell Oil W Aeroshell Oil W 15W-50 Anti-Wear Formulation Aeroshell 15W50	Shell Canada Ltd.
Aeroshell Oil W Aeroshell Oil W 15W-50 Anti-Wear Formulation Aeroshell 15W50	Shell Oil Company
Aviation Oil Type A	Phillips 66 Company
BP Aero Oil	BP Oil Corporation
Castrolaero AD Oil	Castrol Ltd. (Australia)
Chevron Aero Oil	Chevron U.S.A. Inc.
Conoco Aero S	Continental Oil
Delta Avoil	Delta Petroleum Co.
Exxon Aviation Oil EE	Exxon Company, U.S.A.
Mobil Aero Oil	Mobil Oil Company
Pennzoil Aircraft Engine Oil	Pennzoil Company
Quaker State AD Aviation Engine Oil	Quaker State Oil & Refining Co.
Red Ram Aviation Oil 20W-50	Red Ram Ltd. (Canada)
Sinclair Avoil	Sinclair Oil Company
Texaco Aircraft Engine Oil – Premium AD	Texaco Inc.
Total Aero DW 15W50	Total France
Turbonycoil 3570	NYCO S.A.
Union Aircraft Engine Oil HD	Union Oil Company of California

**Figure 8-1**  
**Approved Oils**

## Fuel System Servicing

### *Fuel Filtration Screen/Element*

After the first 25 hours of operation, then every 50-hours or as conditions dictate, the fuel filtration screen in the gascolator must be cleaned. After cleaning, a small amount of grease applied to the gascolator bowl gasket will facilitate reassembly.

Refer to the Airplane Maintenance Manual for Fuel Screen/Element servicing information.

### *Fuel Requirements*

Aviation grade 100 LL (blue) or 100 (green) fuel is the minimum octane approved for use in this airplane.

### *Filling Fuel Tanks*

Observe all safety precautions required when handling gasoline. Fuel fillers are located on the forward slope of the wing. Each wing holds a maximum of 46.0 U.S. gallons. When using less than the standard 92.0 U.S. gallon capacity, fuel should be distributed equally between each side.

### • WARNING •

During fueling have a fire extinguisher available.

Ground fuel nozzle and fuel truck to airplane exhaust pipe and ground fuel truck or cart to suitable earth ground.

Do not fill tank within 100 feet (30.5 meters) of any energized electrical equipment capable of producing a spark.

Permit no smoking or open flame within 100 feet (30.5 meters) of airplane or refuel vehicle.

Do not operate radios or electrical equipment during refuel operations. Do not operate any electrical switches.

To refuel airplane:

1. Place fire extinguisher near fuel tank being filled.
2. Connect ground wire from refuel nozzle to airplane exhaust, from airplane exhaust to fuel truck or cart, and from fuel truck or cart to a suitable earth ground.
3. Place rubber protective cover over wing around fuel filler.

• Note •

Do not permit fuel nozzle to come in contact with bottom of fuel tanks. Keep fuel tanks at least half full at all times to minimize condensation and moisture accumulation in tanks. In extremely humid areas, the fuel supply should be checked frequently and drained of condensation to prevent possible distribution problems.

4. Remove fuel filler cap and fuel airplane to desired level.

• Note •

If fuel is going to be added to only one tank, the tank being serviced should be filled to the same level as the opposite tank. This will aid in keeping fuel loads balanced.

5. Remove nozzle, install filler cap, and remove protective cover.
6. Repeat refuel procedure for opposite wing.
7. Remove ground wires.
8. Remove fire extinguisher.

### ***Fuel Contamination and Sampling***

Typically, fuel contamination results from foreign material such as water, dirt, rust, and fungal or bacterial growth. Additionally, chemicals and additives that are incompatible with fuel or fuel system components are also a source of fuel contamination. To assure that the proper grade of fuel is used and that contamination is not present, the fuel must be sampled prior to each flight.

Each fuel system drain must be sampled by draining a cupful of fuel into a clear sample cup. Fuel drains are provided for the fuel gascolator, wing tanks, and collector tank drains. The gascolator drain exits the lower engine cowl just forward of the firewall near the airplane centerline. Fuel tank and collector tank drains are located at the low spot in the respective tank.

If sampling reveals contamination, the gascolator and tank drains must be sampled again repeatedly until all contamination is removed. It is helpful to gently rock the wings and lower the tail slightly to move contaminants to the drain points for sampling. If after repeated samplings (three or more), evidence of significant contamination remains, do not fly the airplane until a mechanic is consulted, the fuel system is drained and purged, and the source of contamination is determined and corrected.

If sampling reveals the airplane has been serviced with an improper fuel grade, do not fly the airplane until the fuel system is drained and refueled with an approved fuel grade.

To help reduce the occurrence of contaminated fuel coming from the supplier or fixed based operator, pilots should assure that the fuel supply has been checked for contamination and that the fuel is properly filtered. Also, between flights, the fuel tanks should be kept as full as operational conditions permit to reduce condensation on the inside of fuel tanks.

### ***Draining Fuel System***

The bulk of the fuel may be drained from the wing fuel tanks by the use of a siphon hose placed in the cell or tank through the filler neck. The remainder of the fuel may be drained by opening the drain valves. Use the same precautions as when refueling airplane. Refer to the AMM for specific procedures.

## **Battery Service**

The aircraft is delivered with a maintenance-free, rechargeable, sealed, lead acid primary battery. Battery #1 is mounted to the forward right side of the firewall and access is gained by removing the upper cowl. The battery vent is connected to an acid resistant plastic tube that vents gases and electrolyte overflow overboard.

A capacity check must be performed at initial 24 months or 1200 hours in service and then every 12 months or 200 hours thereafter. Refer to the AMM for additional information on Battery #1 Overhaul and Replacement Schedule and Scheduled Maintenance Checks.

• Note •

*For aircraft equipped with conventional lead acid battery requiring periodic electrolyte level check:* Refer to the AMM for information on Battery Overhaul and Replacement Schedule and Scheduled Maintenance Checks.

Battery #2 is a maintenance-free, rechargeable, sealed, lead acid battery. Mounted in the empennage just aft of bulkhead 222, there is no need to check the specific gravity of the electrolyte or add water to these batteries during their service life. Refer to the AMM for Overhaul and Replacement Schedule.

The external power receptacle is located on the left side of the fuselage just aft of the firewall. Refer to the AMM for battery servicing procedures.

## Oxygen System Servicing

### • Caution •

To preclude the possibility of fire by spontaneous combustion, oil, grease, paint, hydraulic fluid, and other flammable material should be kept away from oxygen equipment.

Service the oxygen system per the appropriate revision of the Precise Flight Instructions for Continued Airworthiness for the Cirrus SR22/SR22T Built-In Oxygen System, STC number SA01708SE, document number 102NPMAN0003.

## Key Fob Battery Replacement

*Serials 1233 & subs w/ Convenience Lighting:*

If the key fob does not function properly at normal range, the battery should be replaced. To replace the key fob battery:

1. Using a thin flat object, pry the top and bottom halves of the key fob apart.
2. Remove and replace the battery with a new CR2032, or equivalent, 3-volt battery. Install the new battery with the positive side (+) facing up, away from the circuit board.
3. Press the top and bottom halves of the key fob back together.



# Cleaning and Care

## Cleaning Exterior Surfaces

• Caution •

*Airplane serials with Ice Protection System:* Do not wax leading edge porous panels. Refer to [Section 9: Log of Supplements](#) of this handbook for instructions and limitations for airplanes equipped with the Ice Protection System.

• Note •

Prior to cleaning, place the airplane in a shaded area to allow the surfaces to cool.

The airplane should be washed with a mild soap and water. Harsh abrasives or alkaline soaps or detergents could make scratches on painted or plastic surfaces or could cause corrosion of metal. Cover static ports and other areas where cleaning solution could cause damage. Be sure to remove the static port covers before flight. To wash the airplane, use the following procedure:

1. Flush away loose dirt with water.
2. Apply cleaning solution with a soft cloth, a sponge or a soft bristle brush.
3. To remove exhaust stains, allow the solution to remain on the surface longer.
4. To remove stubborn oil and grease, use a cloth dampened with naphtha.
5. Rinse all surfaces thoroughly.

Any good silicone free automotive wax may be used to preserve painted surfaces. Soft cleaning cloths or a chamois should be used to prevent scratches when cleaning or polishing. A heavier coating of wax on the leading surfaces will reduce the abrasion problems in these areas.

<b>Cleaning Product</b>	<b>Cleaning Application</b>	<b>Supplier</b>
Pure Carnauba Wax	Fuselage Exterior	Any Source
Mothers California Gold Pure Carnauba Wax	Fuselage Exterior	Wal-Mart Stores
RejeX	Fuselage Exterior	Corrosion Technologies
WX/Block System	Fuselage Exterior	Wings and Wheels
AeroShell Flight Jacket Plexicoat	Fuselage Exterior	ShellStore Online
XL-100 Heavy-Duty Cleaner/Degreaser	Fuselage Exterior and Landing Gear	Buckeye International
Stoddard Solvent PD-680 Type II	Engine Compartment	Any Source
Kerosene	Exterior Windscreen and Windows	Any Source
Klear-To-Land	Exterior Windscreen and Windows	D.W. Davies & Co
Prist	Exterior Windscreen and Windows	Prist Aerospace
LP Aero Plastics Acrylic Polish & Sealant	Exterior Windscreen and Windows	Aircraft Spruce & Specialty

**Figure 8-2**  
**Recommended Exterior Cleaning Products**

## Care of Graphics

Graphics require care similar to any fine paint finish. Use high quality products designed specifically for use on automobile finishes. Use products in accordance with the manufacturer's instructions.

### ***Exposure to Environmental Conditions***

Graphics, like paint, are degraded by prolonged exposure to sun and atmospheric pollutants. Store the aircraft in a hangar, under a cloth cover, or in shaded area whenever possible. Protect the aircraft from dew and rain which may contain acidic pollutants (commonly found in large metropolitan areas).

#### **• Caution •**

If graphics start to discolor or turn brown as a result of exposure to acidic pollution, immediately have a professional remove the graphic from the aircraft to avoid staining the underlying paint.

### ***Regular Washing***

Wash graphics whenever the aircraft appears dirty. Contaminants allowed to remain on the exterior may be more difficult to remove.

1. Rinse off as much dirt and grit as possible with a spray of water.
2. Clean graphic with a wet, non-abrasive detergent such as 3M™ Car Wash Soap 39000, Meguiar's NXT Generation® Car Wash, or Deep Crystal® Car Wash, and a soft, clean cloth or sponge.
3. Rinse thoroughly with clean water.
4. To reduce water spotting, immediately use a silicone squeegee to remove water.
5. Dry with a clean microfiber cloth.

### ***Pressure Washing***

Although hand washing is preferred, pressure washing may be used when necessary to remove dirt and contaminants. Pressure washing must be performed in accordance with the following procedure:

1. Ensure the water pressure is less than 2000 psi (14 MPa).
2. Ensure water temperature is less than 180 °F (82 °C).
3. Use a spray nozzle with a 40 degree wide angle spray pattern.

• **Caution** •

Holding the nozzle of a pressure washer at an angle less than 90 degrees to the graphic may lift the edges of the graphic.

4. Keep the spray nozzle perpendicular to the graphic, and at a distance of at least 1 foot (30 cm).
5. To reduce water spotting, immediately use a silicone squeegee to remove water.
6. Dry with a clean microfiber cloth.

***Removing Difficult Contaminants***

Difficult contaminants such as bugs, bird droppings, or tree sap may require spot cleaning.

• **Caution** •

To prevent scratching the graphic, refrain from rough scrubbing and the use of abrasive tools.

1. Soften contaminants by soaking with hot, soapy water for several minutes.
2. Rinse thoroughly with clean water.
3. To reduce water spotting, immediately use a silicone squeegee to remove water.
4. Dry with a clean microfiber cloth.

• **Caution** •

Initially test cleaning products on an inconspicuous area of the graphic to verify they will not cause damage.

5. If further cleaning is needed, one of the following products may be used: Meguiar's Gold Class™ Bug and Tar Remover, 3M™ Citrus Base Cleaner, a mixture of two parts isopropyl alcohol to one part water (mix ratio 2:1), or denatured alcohol.
6. Immediately rinse off all residue with clean water.
7. To reduce water spotting, immediately use a silicone squeegee to remove water.
8. Dry with a clean microfiber cloth.

### ***Cleaning Fuel Spills***

**• Caution •**

Immediately clean fuel spills to avoid degrading the vinyl and adhesive used in the graphic.

1. Wipe off spilled fuel.
2. Clean graphic with a wet, non-abrasive detergent such as 3M™ Car Wash Soap 39000, Meguiar's NXT Generation® Car Wash, or Deep Crystal® Car Wash, and a soft, clean cloth or sponge.
3. Rinse thoroughly with clean water.
4. To reduce water spotting, immediately use a silicone squeegee to remove water.
5. Dry with a clean microfiber cloth.

### Graphic Restoration

If typical cleaning methods fail to produce satisfactory results, refer to the recommended restoration products and mixtures below to help preserve the condition of the graphics on your aircraft.

**• Caution •**

Do not use abrasive polishes or cutting compounds.

Do not use polish or wax on graphics with a matte or texture finish.

Initially test restoration products and mixtures on an inconspicuous area of the graphic to verify they will not cause damage.

**• Note •**

Use an all-purpose cleaner to remove wax or wax residue.

Film or Finish Type	Product or Mixture
Smooth Gloss	3M™ Perfect-it™ Show Car Paste Wax 39526; Meguiar's Gold Class™ Carnuaba Plus Premium Liquid Wax
Matte or Satin Texture	Mixture of two parts isopropyl alcohol to one part water (mix ratio 2:1)
Matte White (1080-M10) Carbon Fiber White Texture (1080-CF10)	Depending on the type and degree of contamination to be removed, use one or more of the following solutions in the order shown: 1. Hot, soapy water solution 2. Mixture of two parts isopropyl alcohol to one part water (mix ratio 2:1) 3. Simple Green® All-Purpose Cleaner 4. Household chlorine bleach, followed by a mixture of two parts isopropyl alcohol to one part water (mix ratio 2:1) 5. Mineral spirits, followed by a mixture of two parts isopropyl alcohol to one part water (mix ratio 2:1)
Carbon Fiber or Brushed Metal Texture	3M™ Tire Restorer or Meguiar's Natural Shine Protectant
Carbon Fiber Black Texture (1080-CF12)	Meguiar's Ultimate Black Plastic Restorer

**Figure 8-3**  
**Recommended Graphic Restoration Products and Mixtures**

### ***Windscreen and Windows***

Before cleaning an acrylic window, rinse away all dirt particles before applying cloth or chamois. Never rub dry acrylic. Dull or scratched window coverings may be polished using a special acrylic polishing paste.

• **Caution** •

Clean acrylic windows with a solvent-free, nonabrasive, antistatic acrylic cleaner. Do not use gasoline, alcohol, benzene, carbon tetrachloride, thinner, acetone, or glass window cleaning sprays.

Use only a nonabrasive cotton cloth or genuine chamois to clean acrylic windows. Paper towel or newspaper are highly abrasive and will cause hairline scratches.

1. Remove grease or oil using a soft cloth saturated with kerosene then rinse with clean, fresh water.

• **Note** •

Wiping with a circular motion can cause glare rings. Use an up and down wiping motion to prevent this.

To prevent scratching from dirt that has accumulated on the cloth, fold cloth to expose a clean area after each pass.

2. Using a moist cloth or chamois, gently wipe the windows clean of all contaminants.
3. Apply acrylic cleaner to one area at a time, then wipe away with a soft, cotton cloth.
4. Dry the windows using a dry nonabrasive cotton cloth or chamois.

### ***Enhanced Vision System Sensor Windows (Optional)***

The Enhanced Vision System Sensor is located on the underside of the LH wing. The three sensor windows are made of Germanium. In contrast to visible light energy, infrared energy typically passes through dirt on the window. As such, the Sensor windows requires only occasional cleaning with mild liquid soap and water or isopropyl alcohol, and a soft cloth.

• **Caution** •

If a EVS Sensor Window breaks, use gloves and masks when handling broken germanium window material.

Do not use abrasive cleansers or cleaning pads on the germanium window. Abrasive cleaning can damage the sensor window coating.

Do not use any cleansers containing ammonia. Ammonia will remove the sensor window coating.

### ***Engine Compartment***

Before cleaning the engine compartment, place a strip of tape on the magneto vents to prevent any solvent from entering these units.

1. Place a large pan under the engine to catch waste.
2. Remove induction air filter and seal off induction system inlet.
3. With the engine cowling removed, spray or brush the engine with solvent or a mixture of solvent and degreaser. In order to remove especially heavy dirt and grease deposits, it may be necessary to brush areas that were sprayed.

#### **• Caution •**

Do not spray solvent into the alternator, vacuum pump, starter, or induction air intakes.

4. Allow the solvent to remain on the engine from 5 to 10 minutes. Then rinse engine clean with additional solvent and allow it to dry.

#### **• Caution •**

Do not operate the engine until excess solvent has evaporated or otherwise been removed.

5. Remove the protective tape from the magnetos.
6. Open induction system air inlet and install filter.
7. Lubricate in accordance with the Airplane Maintenance Manual (AMM), Chapter 12, Servicing.



### ***Landing Gear***

Before cleaning the landing gear, place a plastic cover or similar material over the wheel and brake assembly.

1. Place a pan under the gear to catch waste.
2. Spray or brush the gear area with solvent or a mixture of solvent and degreaser, as desired. Where heavy grease and dirt deposits have collected, it may be necessary to brush areas that were sprayed, in order to clean them.
3. Allow the solvent to remain on the gear from five to ten minutes. Then rinse the gear with additional solvent and allow to dry.
4. Remove the cover from the wheel and remove the catch pan.
5. Lubricate the gear in accordance with the Airplane Maintenance Manual (AMM), Chapter 12, Servicing.

## Cleaning Interior Surfaces

Seats, carpet, upholstery panels, and headliners should be vacuumed at regular intervals to remove surface dirt and dust. While vacuuming, use a fine bristle nylon brush to help loosen particles.

### • Caution •

Remove any sharp objects from pockets or clothing to avoid damaging interior panels or upholstery.

### ***Windshield and Windows***

Never rub dry acrylic. Dull or scratched window coverings may be polished using a special acrylic polishing paste.

### • Caution •

Clean acrylic windows with a solvent free, none abrasive, antistatic acrylic cleaner. Do not use gasoline, alcohol, benzene, carbon tetrachloride, thinner, acetone, or glass window cleaning sprays.

Use only a nonabrasive cotton cloth or genuine chamois to clean acrylic windows. Paper towel or newspaper are highly abrasive and will cause hairline scratches.

### • Note •

Wiping with a circular motion can cause glare rings. Use an up and down wiping motion to prevent this.

To prevent scratching from dirt that has accumulated on the cloth, fold cloth to expose a clean area after each pass.

1. Using a moist cloth or chamois, gently wipe the windows clean of all contaminants.
2. Apply acrylic cleaner to one area at a time, then wipe away with a soft, cotton cloth.

Dry the windows using a dry nonabrasive cotton cloth or chamois.

<b>Cleaning Product</b>	<b>Cleaning Application</b>	<b>Supplier</b>
Prist	Interior Windscreen and Windows	Prist Aerospace
Optimax	Display Screens	PhotoDon
Mild Dishwasher Soap (abrasive free)	Cabin Interior	Any Source
Leather Care Kit 50689-001	Leather Upholstery	Cirrus Design
Leather Cleaner 50684-001	Leather Upholstery	Cirrus Design
Ink Remover 50685-001	Leather Upholstery	Cirrus Design
Leather Conditioner 50686-001	Leather Upholstery	Cirrus Design
Spot and Stain Remover 50687-001	Leather Upholstery	Cirrus Design
Vinyl Finish Cleaner 50688-001	Vinyl Panels	Cirrus Design
Vinyl & Leather Cleaner 51479-001	Vinyl and Leather Upholstery	Cirrus Design

**Figure 8-4  
Recommended Interior Cleaning Products**

### ***Instrument Panel and Electronic Display Screens***

The instrument panel, control knobs, and plastic trim need only to be wiped clean with a soft damp cloth. The multifunction display, primary flight display, and other electronic display screens should be cleaned with Optimax - LCD Screen Cleaning Solution as follows:

**• Caution •**

To avoid solution dripping onto display and possibly migrating into component, apply the cleaning solution to cloth first, not directly to the display screen.

Use only a lens cloth or nonabrasive cotton cloth to clean display screens. Paper towels, tissue, or camera lens paper may scratch the display screen.

Clean display screen with power OFF.

1. Gently wipe the display with a clean, dry, cotton cloth.
2. Moisten clean, cotton cloth with cleaning solution.
3. Wipe the soft cotton cloth across the display in one direction, moving from the top of the display to the bottom. Do not rub harshly.
4. Gently wipe the display with a clean, dry, cotton cloth.

### ***Headliner and Trim Panels***

The airplane interior can be cleaned with a mild detergent or soap and water. Harsh abrasives or alkaline soaps or detergents should be avoided. Solvents and alcohols may damage or discolor vinyl or urethane parts. Cover areas where cleaning solution could cause damage. Use the following procedure:

**• Caution •**

Solvent cleaners and alcohol should not be used on interior parts. If cleaning solvents are used on cloth, cover areas where cleaning solvents could cause damage.

1. Clean headliner, and side panels, with a stiff bristle brush, and vacuum where necessary.
2. Soiled upholstery, may be cleaned with a good upholstery cleaner suitable for the material. Carefully follow the manufacturer's instructions. Avoid soaking or harsh rubbing.

### ***Leather Upholstery and Seats***

For routine maintenance, occasionally wipe leather upholstery with a soft, damp cloth. For deeper cleaning, start with mix of mild detergent and water then, if necessary, work your way up to the products available from Cirrus for more stubborn marks and stains. Do not use soaps as they contain alkaline which will alter the leather's pH balance and cause the leather to age prematurely. Cover areas where cleaning solution could cause damage. Use the following procedure:

**• Caution •**

Solvent cleaners and alcohol should not be used on leather upholstery.

1. Clean leather upholstery with a soft bristle brush, and vacuum where necessary.
2. Wipe leather upholstery with a soft, damp cloth.
3. Soiled upholstery, may be cleaned with the approved products available from Cirrus Design. Avoid soaking or harsh rubbing.

### ***Carpets***

To clean carpets, first remove loose dirt with a whiskbroom or vacuum. For soiled spots and stubborn stains use a non-flammable, dry cleaning fluid. Floor carpets may be cleaned like any household carpet.

Intentionally Left Blank

# ***Section 9: Log of Supplements***

As Required

FAA Approved POH Supplements must be in the airplane for flight operations when the subject optional equipment is installed or the special operations are to be performed.

This Log of Supplements shows all Cirrus Supplements available for the aircraft at the corresponding date of the revision level shown in the lower left corner. A check mark in the Part Number column indicates that the supplement is applicable to the POH. Any installed supplements not applicable to the POH are provided for reference only.



# ***Section 10: Safety Information***

## **Table of Contents**

Introduction .....	3
Cirrus Airframe Parachute System (CAPS) .....	4
Deployment Scenarios.....	4
General Deployment Information .....	7
Landing Considerations .....	8
Taxiing, Steering, and Braking Practices .....	11
Operating Practices .....	11
Brake Maintenance.....	12

Intentionally Left Blank

# Section 10 - Safety Information

## Taxiing, Steering, and Braking Practices

### Operating Practices

*Serials w/ Beringer Brake System:*

Observe the following operating practices:

- Verify that the parking brake is completely disengaged before taxi.
- The rudder is effective for steering on the ground and should be used.
- Use only as much power (throttle) as is necessary to achieve forward movement. Keep in mind, any additional power added with the throttle will be absorbed in the brakes to maintain constant speed.
- Use rudder deflection and the minimum necessary inputs of differential braking to achieve directional control.
- Do not “ride the brakes”. Pilots should consciously remove pressure from the brakes while taxiing. Failure to do so results in excessive heat buildup, premature brake wear, and increased possibility of brake failure or fire.
- Avoid unnecessary high-speed taxiing. High-speed taxiing may result in excessive demands on the brakes, increased brake wear, and the possibility of brake failure or fire.
- Brakes have a large energy absorbing capacity; therefore, cooling time should be considered. Energy absorbed during a few seconds of deceleration can take several minutes to dissipate. Always allow adequate cooling time after brake use.
- Allow a cooling period following a high-energy braking event. High-energy braking can include an aborted takeoff or the equivalent energy required for a Maximum Gross Weight full-stop from 70 knots in less than 1000 feet.

Intentionally Left Blank

## Introduction

This aircraft is designed to operate safely and efficiently in a flight environment. However, like any other aircraft, pilots must maintain proficiency to achieve maximum safety, utility, and economy. Cirrus strongly recommends that all pilots seek regular recurrent training and that they operate in accordance with the Cirrus Flight Operations Manual and Envelope of Safety.

As the pilot you must be thoroughly familiar with the contents of this Handbook, the Handbook Supplements, Flight Checklist, and operational guides and data provided by manufacturers of equipment installed in this airplane. You must operate the airplane in accordance with the applicable FAA operating rules and within the Limitations specified in Section 2 of this Handbook.

The Normal Procedures section of this handbook was designed to provide guidance for day-to-day operation of this airplane. The procedures given are the result of flight testing, FAA certification requirements, and input from pilots with a variety of operational experience. Become fully familiar with the procedures, perform all the required checks, and operate the airplane within the limitations and as outlined in the procedures.

## Cirrus Airframe Parachute System (CAPS)

The Cirrus Airframe Parachute System (CAPS) is designed to lower the aircraft and its passengers to the ground in the event of a life-threatening emergency. CAPS deployment is likely to result in damage to the airframe and, possible injury to aircraft occupants, its use should not be taken lightly. Instead, possible CAPS activation scenarios should be well thought out and mentally practiced by every Cirrus pilot. Pilots who regularly conduct CAPS training and think about using CAPS will often have a higher probability of deploying CAPS when necessary.

The following discussion is meant to guide your thinking about CAPS activation. Cirrus also recommends that pilots discuss CAPS deployment scenarios with instructors as well as fellow pilots through forums such as the Cirrus Owners and Pilots Association. In the event of a spin or loss of aircraft control, immediate CAPS activation is required. (See Section 3) In other situations, CAPS activation is at the informed discretion of the pilot in command. The following discussion is intended to be informative, not directive. It is the responsibility of you, the pilot, to determine when and how the CAPS will be used. It is important to understand, however, that numerous fatalities that have occurred in Cirrus aircraft accidents likely could have been avoided if pilots had made the timely decision to deploy CAPS. It is also important to note that CAPS has been activated by pilots at speeds in excess of 180 knots on multiple occasions with successful outcomes. While the best speed to activate CAPS is below 140 knots indicated airspeed, a timely activation is most important for loss of control situations.

### Deployment Scenarios

This section describes possible scenarios in which the activation of the CAPS is appropriate. This list is not intended to be exclusive, but merely illustrative of the type of circumstances when CAPS deployment could be the only means of saving the occupants of the aircraft.

#### ***Mid-Air Collision***

A mid-air collision likely will render the airplane unflyable by damaging the control system or primary structure. If a mid-air collision occurs, immediately evaluate if the airplane is controllable and structurally capable of continued safe flight and landing. Unless it is apparent that structural and control system damage has not occurred, CAPS

activation is recommended. If you are not sure of the condition of the aircraft following a mid-air collision, CAPS activation is recommended.

### ***Structural Failure***

Structural failure may result from many situations, such as: encountering severe gusts at speeds above the airplane's structural cruising speed, inadvertent full control movements above the airplane's maneuvering speed, or exceeding the design load factor while maneuvering. If a structural failure occurs, CAPS activation is recommended.

### ***Loss of Control***

Loss of control may result from many situations, such as: a control system failure (disconnected or jammed controls); severe wake turbulence, severe turbulence causing upset, severe airframe icing, or pilot disorientation caused by vertigo or panic. If loss of control occurs, the CAPS should be activated immediately.

### **• WARNING •**

In the event of a spin, immediate CAPS activation is mandatory. Under no circumstances should the pilot attempt recovery from a spin other than by CAPS activation.

### ***Landing Required in Terrain not Permitting a Safe Landing***

If a forced landing on an unprepared surface is required CAPS activation is recommended unless the pilot in command concludes there is a high likelihood that a safe landing can be accomplished. If a condition requiring a forced landing occurs over rough or mountainous terrain, over water out of gliding distance to land, over widespread ground fog or at night, CAPS activation is strongly recommended. Numerous fatalities that have occurred in Cirrus aircraft accidents likely could have been avoided if pilots had made the timely decision to deploy CAPS.

While attempting to glide to an airfield to perform a power off landing, the pilot must be continuously aware of altitude and ability to successfully perform the landing. Pilot must make the determination by 2000' AGL if the landing is assured or if CAPS will be required.

### ***Pilot Incapacitation***

Pilot incapacitation may be the result of anything from a pilot's medical condition to a bird strike that injures the pilot. If incapacitation occurs and the passengers are not trained to land the aircraft, CAPS

activation by the passengers is highly recommended. This scenario should be discussed with passengers prior to flight and all appropriate passengers should be briefed on CAPS operation so they could effectively deploy CAPS if required.



## General Deployment Information

### ***Deployment Speed***

The maximum speed at which deployment has been demonstrated is 140 KIAS. Deployment at higher speeds could subject the parachute and aircraft to excessive loads that could result in structural failure. Once a decision has been made to deploy the CAPS, make all reasonable efforts to slow to the minimum possible airspeed. However, if time and altitude are critical, and/or ground impact is imminent, the CAPS should be activated regardless of airspeed.

### ***Deployment Altitude***

No minimum altitude for deployment has been set. This is because the actual altitude loss during a particular deployment depends upon the airplane's airspeed, altitude and attitude at deployment as well as other environmental factors. In all cases, however, the chances of a successful deployment increase with altitude. In the event of a spin, immediate CAPS activation is mandatory regardless of altitude. In other situations, the pilot in command may elect to troubleshoot a mechanical problem or attempt to descend out of icing conditions if altitude and flight conditions permit. As a data point, altitude loss from level flight deployments has been demonstrated at less than 400 feet. Deployment at such a low altitude leaves little or no time for the aircraft to stabilize under the canopy or for the cabin to be secured. A low altitude deployment increases the risk of injury or death and should be avoided. If circumstances permit, it is advisable to activate the CAPS at or above 2,000 feet AGL.

While CAPS activation above 2,000 feet is not necessarily safer than activation at 2,000 feet in terms of the altitude needed to deploy the parachute and slow the descent of the aircraft, there are other risks associated with delaying deployment. Distraction, deterioration in flight conditions, aircraft damage, pilot injury or incapacitation all could take place above 2,000 feet and prevent a timely deployment.

At any altitude, once the CAPS is determined to be the only alternative available for saving the aircraft occupants, deploy the system without delay.

### ***Deployment Attitude***

The CAPS has been tested in all flap configurations at speeds ranging from  $V_{so}$  to  $V_a$ . Most CAPS testing was accomplished from a level attitude. Deployment from a spin was also tested. From these tests it was found that as long as the parachute was introduced to the free air by the rocket, it

would successfully recover the aircraft into its level descent attitude under parachute.

## **Landing Considerations**

After a CAPS deployment, the airplane will descend at less than 1700 feet per minute with a lateral speed equal to the velocity of the surface wind. The CAPS landing touchdown is equivalent to ground impact from a height of approximately 13 feet. While the airframe, seats, and landing gear are designed to accommodate the stress, occupants must be prepared for the landing. The overriding consideration in all CAPS deployed landings is to prepare the occupants for the touchdown in order to protect them from injury as much as possible.

### ***Emergency Landing Body Position***

The most important consideration for a touchdown with CAPS deployed is to protect the occupants from injury, especially back injury. Contacting the ground with the back offset attempting to open a door or secure items increases the likelihood of back injury. All occupants must be in the emergency landing body position well before touchdown. After touchdown, all occupants should maintain the emergency landing body position until the airplane comes to a complete stop.

The emergency landing body position is assumed with tightened seat belt and shoulder harness by placing both hands on the lap, clasping one wrist with the opposite hand, and holding the upper torso erect and against the seat backs. The seat cushions contain an aluminum honeycomb core designed to crush under impact to absorb downward loads and help protect the spine from compression injury.

### ***Door Position***

For most situations, it is best to leave the doors latched and use the time available to transmit emergency calls, shut down systems, and get into the Emergency Landing Body Position well before impact. The discussion below gives some specific recommendations, however, the pilot's decision will depend upon all factors, including time to impact, altitude, terrain, winds, condition of airplane, etc.

There is the possibility that one or both doors could jam at impact. If this occurs, to exit the airplane, the occupants will have to force open a partially jammed door or break through a door window using the Emergency Exit Hammer located in the lid of the center armrest. This can significantly delay the occupants from exiting the airplane.

If the pilot elects to touchdown with a door opened, there are several additional factors the pilot must consider: loss of door, possibility of head injury, or injury from an object coming through the open door.

- If a door is open prior to touchdown in a CAPS landing, the door will most likely break away from the airplane at impact.
- If the door is open and the airplane contacts the ground in a rolled condition, an occupant could be thrown forward and strike their head on the exposed door pillar. Contacting the ground in a rolled condition could be caused by terrain that is not level, contacting an obstacle such as a tree, or by transient aircraft attitude.
- With a door open, it is possible for an object such as a tree limb or flying debris to come through the opening and strike an occupant.

• **WARNING** •

If it is decided to unlatch a door, unlatch one door only. Opening only one door will provide for emergency egress as well as reduce risks associated with ground contact. Typically, this would be the copilot's door as this allows the other occupants to exit first after the airplane comes to rest.

***Water Landings***

The ability of the airplane to float after a water landing has not been tested and is unknown. However, since there is the possibility that one or both doors could jam and use of the emergency egress hammer to break out a window could take some time, the pilot may wish to consider unlatching a door prior to assuming the emergency landing body position in order to provide a ready escape path should the airplane begin to sink.

### ***Post Impact Fire***

If there is no fire prior to touchdown and the pilot is able to shut down the engine, fuel, and electrical systems, there is less chance of a post impact fire. If the pilot suspects a fire could result from impact, unlatching a door immediately prior to assuming the emergency landing body position should be considered to assure rapid egress.

### ***Ground Gusts***

If it is known or suspected that ground gusts are present in the landing zone, there is a possibility that the parachute could drag the airplane after touchdown, especially if the terrain is flat and without obstacles. In order to assure that the occupants can escape the airplane in the timeliest manner after the airplane comes to rest, the pilot may elect to unlatch the copilot's door for the CAPS landing. Occupants must be in the Emergency Landing Body Position for touchdown. Occupants must not loosen seat belts until the airplane comes to rest. When the airplane comes to rest, the occupants should exit the airplane and immediately move upwind to prevent a sudden gust from dragging the airplane in their direction.

## Taxiing, Steering, and Braking Practices

Cirrus aircraft use a castering nose wheel and rely on aerodynamic forces and differential braking for directional control while taxiing. Proper braking practices are therefore critical to avoid potential damage to the brakes.

The most common cause of brake damage and/or failure is the creation of excessive heat through improper braking practices. Pilots unaccustomed to free castering nose wheel steering may be inclined to “ride” the brakes to maintain constant taxi speeds and use the brakes excessively for steering.

### • Caution •

When brake temperatures are between 270-293°F (132-145°C), the Crew Alerting System will display a BRAKE TEMP Caution annunciation. A **BRAKE TEMP Warning annunciation occurs when brake temperature exceeds 293°F (145°C)**. If either annunciation occurs, the pilot should stop the aircraft and allow the brakes to cool to avoid damaging the brake system.

## Operating Practices

When taxiing, directional control is accomplished with rudder deflection and intermittent braking (toe taps) as necessary. Use only as much power as is necessary to achieve forward movement. Deceleration or taxi speed control using brakes but without a reduction in power will result in increased brake temperature.

**On flat, smooth, hard surfaces, do not exceed 1000 RPM maximum continuous engine speed for taxi.** Power settings slightly above 1000 RPM are permissible to start motion, for turf, soft surfaces, and on inclines. Use minimum power to maintain constant taxi speed.

“Riding the brakes” while taxiing is similar to driving a car with one foot on the brake and one foot on the gas. This causes a continuous build up of energy that would otherwise be moving the airplane.

Observe the following operating practices:

- Verify that the parking brake is completely disengaged before taxi.
- The rudder is effective for steering on the ground and should be used.

- Use only as much power (throttle) as is necessary to achieve forward movement. Keep in mind, any additional power added with the throttle will be absorbed in the brakes to maintain constant speed.
- Use rudder deflection and the minimum necessary inputs of differential braking to achieve directional control.
- Do not “ride the brakes”. Pilots should consciously remove pressure from the brakes while taxiing. Failure to do so results in excessive heat buildup, premature brake wear, and increased possibility of brake failure or fire.
- Avoid unnecessary high-speed taxiing. High-speed taxiing may result in excessive demands on the brakes, increased brake wear, and the possibility of brake failure or fire.
- Brakes have a large energy absorbing capacity; therefore, cooling time should be considered. Energy absorbed during a few seconds of deceleration can take up to an hour to dissipate (*Serials 0442 thru 0656, 0658 thru 0689 before SB2X-32-21*), or several minutes to dissipate (*Serials 0442 thru 0656, 0658 thru 0689 after SB2X-32-21, 0657, 0690 & subs*). Always allow adequate cooling time after brake use.
- Allow a cooling period following a high-energy braking event. High-energy braking can include an aborted takeoff or the equivalent energy required for a Maximum Gross Weight full-stop from 70 knots in less than 1000 feet.

## Brake Maintenance

The brake assemblies and linings should be checked at every oil change (50 hours) for general condition, evidence of overheating, and deterioration.

The aircraft should not be operated with overheated, damaged, or leaking brakes. Conditions include, but are not limited to:

- Leaking brake fluid at the caliper. This can be observed by checking for evidence of fluid on the ground or deposited on the underside of the wheel fairing. Wipe the underside of the fairing with a clean, white cloth and inspect for red colored fluid residue.
- Overheated components, indicated by discoloration or warping of the disk rotor. Excessive heat can cause the caliper

components to discolor or cause yellowing of the part identification label.

Refer to Section 8, *Landing Gear Servicing* for specific servicing information on the Brake System.

Intentionally Left Blank